



Bonneagar Iompair Éireann
Transport Infrastructure Ireland

TII Publications

GE PE DN CC OP AM RE

Design of Road Tunnels

DN-STR-03015
December 2000

About TII

Transport Infrastructure Ireland (TII) is responsible for managing and improving the country's national road and light rail networks.

About TII Publications

TII maintains an online suite of technical publications, which is managed through the TII Publications website. The contents of TII Publications is clearly split into 'Standards' and 'Technical' documentation. All documentation for implementation on TII schemes is collectively referred to as TII Publications (Standards), and all other documentation within the system is collectively referred to as TII Publications (Technical). This system replaces the NRA Design Manual for Roads and Bridges (NRA DMRB) and the NRA Manual of Contract Documents for Road Works (NRA MCDRW).

Document Attributes

Each document within TII Publications has a range of attributes associated with it, which allows for efficient access and retrieval of the document from the website. These attributes are also contained on the inside cover of each current document, for reference. For migration of documents from the NRA and RPA to the new system, each current document was assigned with new outer front and rear covers. Apart from the covers, and inside cover pages, the documents contain the same information as previously within the NRA or RPA systems, including historical references such as those contained within NRA DMRB and NRA MCDRW.

Document Attributes

TII Publication Title	<i>Design of Road Tunnels</i>
TII Publication Number	<i>DN-STR-03015</i>

Activity	<i>Design (DN)</i>
Stream	<i>Structures (STR)</i>
Document Number	<i>03015</i>

Document Set	<i>Standards</i>
Publication Date	<i>December 2000</i>
Historical Reference	<i>BD 78</i>

NRA DMRB and MCDRW References

For all documents that existed within the NRA DMRB or the NRA MCDRW prior to the launch of TII Publications, the NRA document reference used previously is listed above under 'historical reference'. The TII Publication Number also shown above now supersedes this historical reference. All historical references within this document are deemed to be replaced by the TII Publication Number. For the equivalent TII Publication Number for all other historical references contained within this document, please refer to the TII Publications website.

NRA ADDENDUM TO

BD 78/99

DESIGN OF ROAD TUNNELS

Standard BD 78/99 – Design of Road Tunnels – is applicable in Ireland with the following amendments:

GENERAL

1. This Standard provides specification requirements for use in public purchasing contracts. It does not lay down legislation requirements for products and materials used in road construction in Ireland.
2. At several locations:
 - For: “Overseeing Organisation”
Read: “National Roads Authority”;
 - For: “Technical Approval Authority” or “TAA”
Read: “National Roads Authority”;
 - For: “Technical Approval Authority of the Overseeing Organisation”
Read: “National Roads Authority”;
 - For: “highway”
Read: “road”;
 - For: “BD2 (DMRB 1.1)”
Read: “NRA BD2 (NRA DMRB 1.1)”;
 - For: “trunk road”
Read: “national road”;
 - For: “heavy goods vehicles” or “HGVs”
Read: “Heavy Commercial Vehicles”;
 - For: “Approval in Principle (AIP)” or “AIP”
Read: “Preliminary Approval”;
 - For: “Police”
Read: “Garda”;
 - For: “TD9 (DMRB 6.1.1)”
Read: “NRA TD9 (NRA DMRB 6.1.1)”;
 - For: “TD27 (DMRB 6.1.2)”
Read: “NRA TD27 (NRA DMRB 6.1.2)”;
 - For: “the Secretary of State”
Read: “the Minister for the Environment”;

For: “Traffic Signs Regulations and General Directions” or “Traffic Signs Regulations”
Read: “Road Traffic (Signs) Regulations”;

For: “Maintaining Agent”
Read: “Tunnel Operating Authority”.

SPECIFIC

1. Introduction

- 1.1 Page 1/1, Paragraph 1.1, line 4:
For: “United Kingdom”
Read: “Ireland.”
- 1.2 Page 1/1, Paragraph 1.6, line 7 and Paragraph 1.9, line 2:
For: “under preparation.” (two locations)
Read: “under preparation by the UK Highways Agency.”
- 1.3 Page 1/1, Paragraph 1.8, line 9:
After “under preparation” insert:
“by the UK Highways Agency. These specifications are for tunnels in the United Kingdom. However, they may be used as the basis for a specification for tunnels in Ireland.”
- 1.4 Page 1/2, Paragraph 1.14, line 11:
Delete: “of BD 53 (DMRB 3.1.6)”.
- 1.5 Page 1/3, Paragraph 1.17, line 4:
Delete second, third and fourth sentences “Reference should ... Act 1988.” and replace with:
“Reference should be made to the latest relevant Irish and EEC legislation, IS, ISO, BS or other EC member states’ Standards, and relevant NRA and Department of Environment documents, at an early stage in the tunnel planning process. A special order/scheme may be required for a national road/motorway in tunnel under a navigable watercourse. Tolled tunnels under estuaries may be controlled by special legislation, e.g. the UK Dartford-Thurrock Crossing Act 1988.”
- 1.6 Page 1/3, Paragraph 1.18:
Delete Paragraph 1.18 and replace with:
“1.18 This Standard should be used forthwith for all schemes for the construction and/or improvement of national roads. The Standard should be applied to the design of schemes already being prepared unless, in the opinion of the National Roads Authority, application would result in significant additional expense or delay progress. In such cases, Design Organisations should confirm the application of this Standard to particular schemes with the National Roads Authority.”

2. Planning, Safety, General Design Considerations

- 2.1 Page 2/1, Paragraph 2.6, line 1:
For: “Value Management and Value Engineering, Risk Analysis and Management (Value for Money Manual : Highways Agency: June 1996) shall be used”
Read: “Value management and value engineering, risk analysis and management (for example, Value for Money Manual : Highways Agency: June 1996) should be used”.
- 2.2 Page 2/1, Paragraph 2.8(i), line 6:
For: “This type of tunnel operation includes tunnels built under Acts of Parliament such as toll tunnels and the major estuarine crossings (Clyde, Dartford, Mersey, Tyne etc).”
Read: “This type of tunnel operation includes tunnels such as toll tunnels and major estuarine crossings (e.g. the UK Clyde, Dartford, Mersey and Tyne tunnels).”
- 2.3 Page 2/2, Paragraph 2.10, line 10:
Delete final sentence: “For Highways Agency..... Network Area Manager.”
- 2.4 Page 2/2, Paragraph 2.12, line 7:
Delete third sentence “For UK ... (DMRB1.1).” and replace with:
“For road tunnels schemes in Ireland, and also where a local Road Authority requires, the NRA will be the appropriate body responsible for granting preliminary approval, see NRA BD 2 (DMRB 1.1).”
- 2.5 Page 2/2, Paragraphs 2.14 to 2.18:
[Note: the above paragraphs provide detailed advice on safety procedures that should be used in the UK. For use in Ireland, the Design Organisation shall agree with the NRA the procedures and legislations to be followed.]
- 2.6 Page 2/2, Paragraph 2.15, line 2:
For: “HD 19 (DMRB 5.2.2) and accompanying advice in HA 42 (DMRB 5.2.3).”
Read: “NRA HD 19 (NRA DMRB 5.2.2) and accompanying guidance in NRA HA 42 (NRA DMRB 5.2.3)”.
- 2.7 Page 2/5, Paragraph 2.37, line 14:
For: “Traffic Safety Measures and Signs for Roadworks and Temporary Situations: SO”
Read: “Signs for Roadworks”.
- 2.8 Page 2/7, Third Heading (after Paragraph 2.54), line 1:
For: “**Tunnel Service Buildings, Tunnel Portals: Land and Royal Fine Art Commission/Commission for Architecture and the Built Environment Requirements**”
Read: “**Tunnel Service Buildings and Tunnel Portals**”.
- 2.9 Page 2/7, Paragraph 2.56:
Delete Paragraph 2.56 and replace with:
“2.56 Service Buildings are part of the complete tunnel and road scheme and are not treated as a separate development. The buildings and tunnel portal areas, particularly for a major scheme or one in a National Heritage Area or near buildings of architectural or historic interest or conservation areas may need special consideration. The form and appearance of such service buildings and tunnel portals should be discussed at an early stage with both the National Roads Authority and the Local Roads Authority.”

2.10 Page 2/9, Paragraph 2.70, line 1:
Delete first sentence “BD2 ... equipment.” and replace with:
“2.70 NRA BD 2 (NRA DMRB 1.1) outlines the requirements for technical approval of the road tunnel structure and equipment. Details shall be agreed with the National Roads Authority.”

2.11 Page 2/9, Paragraph 2.71, line 14:
Delete: “IAN 15 (DMRB 2.1) and”.

2.12 Page 2/10, Paragraph 2.77, line 9:
Delete last sentence “Year 2000 ... (BSI).”

2.13 Page 2/11, Paragraph 2.80:
Delete Paragraph 2.80 and replace with:
“2.80 Highway loadings, over and through a road tunnel, are as described in BD 37 (DMRB 1.3). For cases such as transverse spanning, suspended road decks and road slabs supported on the ground, where it is not possible to determine the effective loading lengths for HA udl (uniformly distributed loading), then the vehicle loadings shall be agreed with the National Roads Authority. The NRA will provide details of any Abnormal Indivisible Loading (AIL) vehicles to be included in design or assessment.”

3. Operational Classification of Safety Facilities for the Road Users

3.1 Page 3/4, Paragraph 3.28, line 8:
For: “Highways Agency Value for Money Manual.”
Read: “UK Highways Agency Value for Money Manual.”

4. Geometric Design

4.1 Page 4/1, Paragraph 4.6, line 3, and
Page 4/5, Table 4.1, Column 3, Rows 2 & 3:
For: “TD 20 (DMRB 5.1)”
Read: “TA 46 (DMRB 5.1.3) and TA 79 (DMRB 5.1)”.

4.2 Page 4/2, Paragraph 4.7, line 5:
For: “for the flow rates set out in TD 20 (DMRB 5.1).”
Read: “for flow rates which shall be agreed with the National Roads Authority (guidance may be obtained from TA 46 and TA 79 (DMRB 5.1.3 and 5.1 respectively))”.

5. Ventilation

5.1 Page 5/9, Paragraph 5.82, line 7:
For: “carried out for Department of Environment”
Read: “carried out for the UK Department of Environment”.

5.2 Page 5/10, Paragraph 5.89, line 2:
For: “at Mersey Tunnel and”
Read: “at Mersey Tunnel, UK, and”.

-
- 5.3 Page 5/13, Paragraph 5.104, line 7:
For: “BSEN1793.”
Read: “IS EN 1793: 1998.”
- 5.4 Page 5/14, Paragraph 5.117, line 6:
For: “tunnel and TD 20 Appendix 2 (DMRB 5.1.3) and TA 46 (DMRB 5.1.4).”
Read: “tunnel, see also TA 46 (DMRB 5.1.3) and TA 79 (DMRB 5.1).”
- 5.5 Page 5/15, Paragraph 5.126, line 4:
For: “from 1990”
Read: “from 1993”.
- 5.6 Page 5/15, Paragraph 5.140:
Delete Paragraph 5.140 and replace with:
“5.140 The limits, given in Tables 5.1 to 5.3, are based on the recommendations of PIARC 1995: Emissions, Ventilation and Environment and UK Health and Safety Executive (HSE) document EH40: Occupational Exposure Limits. For new design or refurbishment of tunnels in Ireland, the Design Organisation shall consult the Health and Safety Authority concerning the acceptable limits, which shall be agreed with the National Roads Authority.”
- 5.7 Page 5/16, Paragraph 5.142, line 1:
For: “European and UK emissions”
Read: “European and Irish emissions”.
- 5.8 Page 5/16, Paragraph 5.142, line 7:
For: “standards and their dates can be found”
Read: “standards and their dates in the UK can be found”.
- 5.9 Page 5/16, Paragraph 5.143, line 3:
For: “national fleet”
Read: “UK national fleet”.
- 5.10 Page 5/16, Paragraph 5.149, line 6:
Delete third, fourth and fifth sentences “Two of the ... road tunnel” and replace with:
“Concentrations in tunnels shall be subject to the limits set by the Environmental Protection Agency.”
- 5.11 Page 5/16, Paragraph 5.151, line 1:
For: “Standards and limits for occupational exposure are given”
Read: “Standards and limits for occupational exposure in the UK are given”.
- 5.12 Page 5/16, Paragraph 5.151:
Insert at the end of Paragraph 5.151:
“The Design Organisation shall consult the Health and Safety Authority for acceptable standards and limits for occupational exposure in Ireland, which shall be agreed with the National Roads Authority”.
- 5.13 Page 5/17, Paragraph 5.154:
Delete Paragraph 5.154 and replace with:
“5.154 Standards for lead in air shall be those set by the Environmental Protection Agency.”

- 5.14 Page 5/20, Paragraph 5.194, line 2:
Delete: “to BD 53 (DMRB 3.1.6)”.
- 5.15 Page 5/23 to 5/25, Tables 5.4 to 5.8, tables titles:
Insert at the end of each title: “**in the UK**”.

7. Drainage

- 7.1 Page 7/1, Paragraph 7.7, line 2:
Delete: “**HA 71 (DMRB 4.2.1) and**”.
- 7.2 Page 7/4, Paragraph 7.45, line 3:
For: “**BS5345: Part 2**”
Read: “**IS EN 60079-10: 1996**”.

8. Fire Safety Engineering

- 8.1 Page 8/1, Paragraph 8.1, line 10:
For: “Home Office”
Read: “UK Home Office”.
- 8.2 Page 8/4, Paragraph 8.31, line 2:
For: “BS EN 3 Part 1,”
Read: “IS EN 3 Part 1”.
- 8.3 Page 8/4, Paragraph 8.32, line 5:
For: “BS EN 671-1: 1995.”
Read: “IS EN 671-1: 1995.”

9. Traffic Control, Communications and Information System

- 9.1 Page 9/1, Paragraph 9.5:
Delete Paragraph 9.5 and replace with:
“**9.5 Communication and signalling systems used to monitor and control traffic for motorways and other national roads shall be of a type approved, in writing, on behalf of the Minister for the Environment and Local Government, or National Roads Authority. Signs and signals used for traffic control shall meet the requirements of the Road Traffic (Signs) Regulations. Equipment shall have an approval issued on behalf of the Department of Environment. Advice on responsibilities/approval for signing/signalling shall be sought from the National Roads Authority.**”
- 9.2 Page 9/2, Paragraph 9.19, line 2:
For: “relevant British and/or European Standards.”
Read: “relevant Irish, British and/or European Standards.”
- 9.3 Page 9/4, Paragraph 9.55, line 4:
For: “Examples of tunnel signing are given in”
Read: “Examples of tunnel signing used in the UK are given in”.

9.4 Page 9/5, Paragraph 9.56:
Delete Paragraph 9.56 and replace with:
“9.56 Advice on responsibilities/approval for signing/signalling on static signs, variable message, signalling and sign lighting shall be sought from the National Roads Authority.”

9.5 Page 9/5, Paragraph 9.71, line 2:
Delete: “Schedule 6 of”.

9.6 Page 9/7, Paragraph 9.94:
Delete Paragraph 9.94 and replace with:
“9.94 All radio transmission systems within a tunnel, including those for emergency services, require the approval of, and a licence from, the Office of the Director of Telecommunications Regulation.”

10. Plant Monitoring and Control

10.1 Page 10/1, Paragraph 10.1, line 15:
For: “based on NMCS2”
Read: “based on UK NMCS2”.

10.2 Page 10/4, Paragraph 10.32, line 4:
Delete: “as required by BD 53 (DMRB 3.1.6)”.

11. Electrical Power Supply and Distribution

11.1 Page 11/3, Paragraph 11.24, line 10:
For: “Electricity at Work Regulations 1989”
Read: “Safety, Health and Welfare at Work (General Application) Regulations, 1993, Section VIII: Electricity”.

11.2 Page 11/8, Paragraph 11.92, line 2:
For: “to the Manual of Contracts Documents for Highway Works.”
Read: “to specifications and standards agreed with the National Roads Authority.”

13. Tunnel Commissioning, Handover and Operational Downstation

13.1 Page 13/1, Paragraph 13.2, line 6:
At the end of Paragraph 13.2 insert:
“The application of these specification requirements shall be agreed with the National Roads Authority.”

13.2 Page 13/2, Paragraph 13.12(iii), line 5:
For: “See the Manual of”
Read: “For a suitable format, see the Manual of”.

13.3 Page 13/2, Paragraph 13.18, line 9:
Delete: “See BD 53 (DMRB 3.1.6).”

13.4 Page 13/3, Paragraph 13.22, final line:
Delete: “by BD 53 (DMRB 3.1.6).”

- 13.5 Page 13/4, Paragraph 13.28, final line:
Delete: “to BD 53 (DMRB 3.1.6)”.

14. Tunnel Operation and Maintenance

- 14.1 Page 14/4, Paragraph 14.37, line 5:
Delete second sentence “The Safety Officer ... Regulations 1988.” and replace with:
“The Safety Officer shall be responsible for the requirements of The Safety, Health and Welfare at Work Act 1989 and the regulations made under its powers, such as Control of Specific Substances and Activities Regulations 1991.”
- 14.2 Page 14/4, Paragraph 14.40, line 2:
For: “Electricity at Work Regulations 1989, Health and Safety at Work Act 1974”
Read: “Safety, Health and Welfare at Work (General Application) Regulations 1993 (Section VIII: Electricity), the Safety, Health and Welfare at Work Act 1989”.
- 14.3 Page 14/4, Paragraph 14.41, line 2:
For: “Overseeing Authority”
Read: “National Roads Authority”.
- 14.4 Page 14/5, Paragraph 14.46(iii), line 8:
Delete: “BD 53 (DMRB 3.1.6)”.
- 14.5 Page 14/6, Paragraph 14.51, line 6:
Delete second and third sentences “BD53 ... emergency repairs.” and replace with:
“The inspection types should be such that they lead to no surprises and consequent unplanned closures for emergency repairs.”
- 14.6 Page 14/6, Paragraph 14.53, line 15:
Delete: “but are believed not to be legal under the current Highways Act.”

15. References and Glossary

- 15.1 Page 15/1, Paragraph 15.2, line 1:
For: “Departmental Standards of the DMRB”
Read: “Standards of the UK DMRB”.
- 15.2 Pages 15/1 to 15/6, at several locations:
For: “*Overseeing Organisation Publications*”
Read: “*NRA and Highways Agency Publications*”.
- 15.3 Pages 15/1 to 15/8, Section 15.8, at several locations:
For: “Departmental Standard BD2 (DMRB 1.1) Part III – The Technical Approval of Highway Structures on Motorways and Other Trunk Roads: Procedures for Tunnels”
Read: “NRA BD2 (NRA DMRB 1.1) - Technical Approval of Road Structures on Motorways and Other National Roads”.
- 15.4 Page 15/2, Section 15.8, **Chapter 2**, *Overseeing Organisation Publications* (xiv) and (xv):
Delete references (xiv) and (xv) and replace with:
“xiv. Standard NRA HD 19 (NRA DMRB 5.2.2)
– Road Safety Audits.
xv. NRA Road Safety Audit Guidelines.”

- 15.5 Page 15/2, Section 15.8, **Chapter 2**, *Overseeing Organisation Publications*:
Insert new reference:
“xxi. Advice Note TA 79 (DMRB 5.1) – Traffic Capacity for Urban Roads”.
- 15.6 Page 15/2, Section 15.8, **Chapter 2**, *British Standards*, (ii) and Page 15/5, Section 15.8, **Chapter 6**, *British Standards*, (ii):
For: “BS 5266, Part 1: 1975” (two locations)
Read: “BS 5266, Part 1: 1988”.
- 15.7 Page 15/4, Section 15.8, **Chapter 4**, *Overseeing Organisation Publications*, (i) and (iii):
Delete (i) and (iii) and replace with:
“i. NRA TD 9 (NRA DMRB 6.1.1) – Road Link Design.

iii. NRA TD 27 (NRA DMRB 6.1.2) – Cross Sections and Headroom”.
- 15.8 Page 15/5, Section 15.8, **Chapter 7**, **Drainage**, (viii):
Delete (viii) and replace with:
“viii. IS EN 60079-10: 1996. Electrical Apparatus for Explosive Gas Atmospheres: Part 10 Classification of Hazardous Areas.”
- 15.9 Page 15/7, Section 15.8, **Chapter 9**, *Other Documents*, (i):
Delete (i) and replace with:
“i. Road Traffic (Signs) Regulations 1997”.
- 15.10 Page 15/7, Section 15.8, **Chapter 10**, (iii):
For: “BS EN 60695”
Read: “IS EN 60695”.
- 15.11 Page 15/7, Section 15.8, **Chapter 11**, (ii):
Delete (ii) and replace with:
“ii. Safety, Health and Welfare (General Application) Regulations, 1993, Section VIII: Electricity.”
- 15.12 Page 15/7, Section 15.8, **Chapter 14**, (i), (ii) and (iii):
Delete (i), (ii) and (iii) and replace with:
“i. Safety, Health and Welfare at Work Act 1989.

ii. Safety, Health and Welfare (General Application) Regulations, 1993, Section VIII: Electricity.

iii. Control of Specific Substances and Activities Regulations 1991.”
- 15.13 Page 15/8, Section 15.8, **Appendix B**, (ii):
Delete (ii) and replace with:
“ii. NRA Manual of Contract Documents for Road Works:
Volume 1, Specification for Road Works
Volume 2, Notes for Guidance on the Specification for Road Works.”

16. Enquiries

16.1 Page 16/1, Chapter 16:

Delete text and replace with:

“16.1 All technical enquiries or comments on this Standard should be sent in writing to:

Head of Project Management and Engineering
National Roads Authority
St Martin’s House
Waterloo Road
Dublin 4”.

17. Appendix B

17.1 Page B1/1, Paragraph B.3, line 5:

For: “The Specification for Highway Works,”

Read: “The NRA Specification for Road Works,”.

18. Appendix C

18.1 Page C1/5, Paragraph *Communications*, line 6:

For: “with BT (British Telecom) telephone numbers”

Read: “with Eircom (formerly Telecom Eireann) telephone numbers”.

19. Appendix E

19.1 Page E1/1, Appendix E, at several locations:

For: “Highways Agency”

Read: “UK Highways Agency”.

19.2. Page F1/2, Paragraph *Chapter 8* (iii), line 3:

Delete: “as required by BD 53 (DMRB 3.1.6)”.



.....
E O’CONNOR
Head of Project Management and Engineering

**VOLUME 2 HIGHWAY STRUCTURES
DESIGN (SUB-
STRUCTURES AND
SPECIAL STRUCTURES)
MATERIALS**

SECTION 2 SPECIAL STRUCTURES

PART 9

BD 78/99

DESIGN OF ROAD TUNNELS

SUMMARY

This Standard describes the procedures required for the design of new or refurbished road tunnels located within Motorways and Other Trunk Roads. It gives guidance on the necessary equipment and Operational and Maintenance Systems that need to be considered by the designer to facilitate continued effective and safe operation.

INSTRUCTIONS FOR USE

This is a new document to be inserted into the Manual

1. Insert Part 9 into Volume 2, Section 2.
2. Archive this sheet as appropriate.

Note: A quarterly index with a full set of Volume Contents Pages is available separately from The Stationery Office Ltd.



THE HIGHWAYS AGENCY



**THE SCOTTISH EXECUTIVE DEVELOPMENT
DEPARTMENT**



**THE NATIONAL ASSEMBLY FOR WALES
CYNULLIAD CENEDLAETHOL CYMRU**



**DEPARTMENT OF THE ENVIRONMENT FOR
NORTHERN IRELAND**

Design of Road Tunnels

Summary: This Standard describes the procedures required for the design of new or refurbished road tunnels located within Motorways and Other Trunk Roads. It gives guidance on the necessary equipment and Operational and Maintenance Systems that need to be considered by the designer to facilitate continued effective and safe operation.

REGISTRATION OF AMENDMENTS

Amend No	Page No	Signature & Date of incorporation of amendments	Amend No	Page No	Signature & Date of incorporation of amendments

REGISTRATION OF AMENDMENTS

Amend No	Page No	Signature & Date of incorporation of amendments	Amend No	Page No	Signature & Date of incorporation of amendments

**VOLUME 2 HIGHWAY STRUCTURES
DESIGN (SUB-
STRUCTURES AND
SPECIAL STRUCTURES)
MATERIALS**

SECTION 2 SPECIAL STRUCTURES

PART 9

BD 78/99

DESIGN OF ROAD TUNNELS

Contents

Chapter

1. Introduction
2. Planning, Safety, General Design Considerations
3. Operational Classification of Safety Facilities for the Road User
4. Geometric Design
5. Ventilation
6. Tunnel Lighting
7. Drainage
8. Fire Safety Engineering
9. Traffic Control, Communications and Information Systems
10. Plant Monitoring and Control
11. Electrical Power Supply and Distribution
12. Services Buildings and Plant Rooms
13. Tunnel Commissioning, Handover and Operational Documentation
14. Tunnel Operation and Maintenance
15. References and Glossary
16. Enquiries

Appendices

- A Secondary Cladding
- B Durability and Materials
- C Tunnel Documentation: Typical Contents
- D Guidelines for Major Incident Operations and Fire Tests
- E Recent Research by the Highways Agency
- F Tunnel Design and Safety Consultation Group (TDSCG) Requirements
- G Life Expectancy of Tunnel Equipment

1. INTRODUCTION

General

1.1 This document provides the requirements and essential guidance for decision making relevant to the effective planning, design, operation and major refurbishment of road tunnels in the United Kingdom. It combines a Directive type Standard with an Advice Note. The document is intended for a wider readership than tunnel designers alone. Throughout, emphasis is placed on the wider aspects of design as they apply to the essential aspects of operation and maintenance of such relatively expensive structures over their operational lives. For Trans-European Motorways a separate United Nations document Standards and Recommended Practice: Tunnels, July 1992, applies to support the European Agreement on Main International Traffic Arteries (AGR).

1.2 A road tunnel is a subsurface highway structure enclosed for a length of 150m, or more. The operational equipment requirements described in this Standard for such structures vary with length, location, speed and traffic volume. Where security considerations permit, the use of central light wells may provide economies but the tunnel length shall not be considered to be reduced in any way for classification purposes.

1.3 Aspects of the document will be of particular interest to parties such as the traffic police, fire and ambulance services, maintaining and environmental authorities as well as those involved with the several specialisms of engineering needed to contribute to an effective and efficient road tunnel design.

1.4 Emphasis is placed on the early and detailed consideration that must be given, by the relevant parties involved, to the particular aspects of safety peculiar to the construction and operation of road tunnels and the overall cooperation, interaction and teamwork that successful tunnel design and operation entails. Chapters have been written to be as self contained as possible with a minimum of cross referencing.

1.5 It should be understood that for such a wide and developing topic, the guidance provided herein should not be considered as to be exhaustive. It is not intended to provide any form of substitute for the special expertise that is needed to prepare effective and efficient working designs for a road tunnel.

Scope of Document

1.6 The document provides information on the general considerations and specific design and operational requirements of road tunnels, together with details of the tunnel maintenance, and operational documentation that is involved. A separate document to advise further on the specific requirements of road tunnel maintenance is currently under preparation.

1.7 Many aspects of tunnel design, construction, equipping and operation are currently undergoing rapid development and improvement. This document has purposely kept to describing the essential principles of good practice rather than to be unnecessarily prescriptive. Reference is made to a selection of the current publications and research documents which could be of assistance to designers and operators.

1.8 Much of the detailed technical specification requirements for road tunnel equipment may be found in the Manual of Contract Documents for Highway Works: Volume 5: Section 7: Mechanical and Electrical Installations in Road Tunnels, Movable Bridges and Bridge Access Gantries. A separate specification document to advise on the specific civil engineering requirements of road tunnel construction and maintenance is currently under preparation.

1.9 Due to the wide variation in the engineering considerations that influence the structure and form of a tunnel, references to civil engineering aspects within the document are necessarily limited in scope. Guidance is given on such common aspects as for example space requirements for traffic, equipment, profile for traffic safety etc and the consideration to be given to fire protection of the structure. Separate documents to advise on such aspects as the New Austrian Tunnelling Method, Limited Facility ('low height, car only') Tunnels and the Observational Method are currently under preparation. The Standard does not cover surface tunnels, a subject currently being studied in several countries including the UK and by PIARC Tunnels Committee, for environmental mitigation.

Mandatory Requirements

1.10 Sections of the document which form part of the mandatory requirements of the Overseeing Organisation ('the client') for road tunnels are contained within

paragraphs in bold text. These are the sections of the document with which the Design Organisation ('the designer') must comply, or will have agreed beforehand a suitable Departure from Standard with the relevant Overseeing Organisation, in accordance with BD2 (DMRB 1.1) of the Design Manual for Roads and Bridges. Elsewhere in the document, where the word "shall" is used then the requirement is expected to be carried out in full unless, for the circumstances of a particular scheme, a recorded agreement has been made with the Overseeing Organisation beforehand that a more suitable way, of conforming with the intention of a particular requirement, is to be used. The remainder of the document contains advice which is commended to designers and operators for their consideration. Legal requirements are non negotiable and are not described within emboldened text.

Tunnel Design and Safety Consultation Group (TDSCG)

1.11 It is necessary for various interested parties (see below) to meet together as a group in order to contribute their specific specialist knowledge and experience to clarify requirements for tunnel construction or refurbishment projects. For effective design, construction and operation of a road tunnel the agreement and setting of appropriate standards of safety, quality and economy depend heavily on early discussion between the parties concerned and on a clear definition of the scope of work and performance and reliability requirements. Such meetings shall be arranged to be as efficient and effective as possible with respect to staff time and budget restraints of contributing parties.

1.12 In order to confirm basic design and operating procedures in the context of fully integrated systems for traffic management, signs and signalling, communication, information, plant monitoring and control a Tunnel Design and Safety Consultation Group shall be set up. It shall comprise appropriate levels of representation from the Overseeing Organisation, Design Organisation, Police or other control authority, Maintaining Agent and Emergency Services. The TDSCG will review and co-ordinate standards of communication and the appropriate, but not excessive, means of equipping and operating a tunnel in the light of consultations between all interested parties. The Project Manager of the Overseeing Organisation (Design Organisation for DBFO schemes) shall ensure that the Group has terms of reference that will enable it to identify potential hazards involving vehicle breakdown, traffic congestion and full scale emergencies, including fire.

For DBFO schemes, the Overseeing Organisation shall formally approve such terms of reference. The Project Manager of the Overseeing Organisation (Design Organisation for DBFO schemes) shall chair all such meetings and make provision for all secretarial duties.

1.13 The Group shall meet regularly throughout the design and construction periods and agree working procedures for day to day operation, planned maintenance requirements (including contra-flow) and ensure that in the event of an emergency contingency plans will enable tunnel services and traffic flows to be restored as quickly as possible. Although not party to the technical approvals procedures, the agreed recognition and acceptance of the proposals by the Police or other control authority, Emergency Authorities and the Tunnel Operating Authority shall be recorded. Similarly, acceptance by the Water Authority of likely drainage outfalls from the tunnel must also be recorded. The decisions effecting the design and operation confirmed and agreed at TDSCG meetings must be formally recorded into a finalised Report of the TDSCG, and accepted as an agreed addenda to the Approval In Principle (AIP) document required by BD2 (DMRB 1.1).

1.14 The TDSCG should complete most, if not all, of its work prior to the start of construction and the procurement of any operational equipment relevant to the agreement of the TDSCG. For schemes procured by design and build (D&B) and design, build, finance and operate (DBFO) methods the Overseeing Organisation shall hold at least one inaugural TDSCG meeting prior to tender. Following tender award the TDSCG will continue to meet throughout the design and commissioning stages of the project until the emergency drill requirement of BD53 (DMRB 3.1.6) prior to tunnel opening to traffic, has been completed and any adverse findings from the drill have been formally addressed.

1.15 Appendix F gives a summary of the items normally to be discussed by the TDSCG. Additional topic items may be required to deal with specific requirements of particular road tunnel projects.

Reference to British Standards and Legislation

1.16 Any reference to a British Standard can be taken to include any other International Standard or National Standard of another Member State of the European Communities, which is comparable in its scope and safety requirements to the given British Standard.

1.17 This document is not intended as a legal manual and any references made to legislation are intended only as an indication of the possible legal requirements. Reference should be made to the latest relevant UK and EEC legislation, ISO, BS or other EC Member States' Standards and relevant Department of Environment Transport and Regions documents, at an early stage in the tunnel planning process. Under the Highways Act 1980, a special order/scheme is required for a trunk road/motorway in tunnel under a navigable watercourse. Tolloed tunnels under estuaries may be controlled by special legislation eg the Dartford- Thurrock Crossing Act 1988. The designed provisions and operational procedures shall not discriminate unlawfully against disabled road users of a tunnel.

Implementation

1.18 This document should be used forthwith on all schemes for the construction, refurbishment and maintenance of tunnels on trunk roads including motorways, currently being prepared, provided that, in the opinion of the Overseeing Organisation, this would not result in significant additional expense or delay progress. Design Organisations shall confirm its application to particular schemes with the Overseeing Organisation.

2. PLANNING, SAFETY, GENERAL DESIGN CONSIDERATIONS

General

2.1 This Chapter describes factors influencing the design and operation of road tunnels in order to establish the broad planning and safety issues that are involved at preliminary design stage. Other Chapters of this document contain information on the more detailed design considerations and particular requirements that will need to be applied once a tunnel project has reached the detailed design stage.

2.2 Because of the relatively high capital cost, there may be justification for carrying out road tunnel schemes on a staged basis, eg only initially building one bore of a twin bore tunnel. Conversely, there may be economies of scale in carrying out more extensive works at an earlier stage. All such factors shall be considered at the initial route selection and planning stages.

2.3 Current planning and scheme appraisal procedures for new road schemes provide the framework to enable road tunnel options to be considered in direct comparison with open road proposals, including bridge alternatives. Although tunnel options are recognised as being generally, but not exclusively, more expensive than open road options they are capable of providing considerable environmental benefits and practical solutions in schemes with existing congested infrastructure, navigable river crossings or through hilly and mountainous terrains.

2.4 For each project containing a road tunnel, a comprehensive appraisal of factors contributing towards a safe tunnel environment for road users, local inhabitants, operators, maintenance staff, police and emergency services, shall be undertaken at an early stage of the planning process.

2.5 The planning and design of tunnel options should initially be to the same highway standards as for open road options. However, a number of characteristics of roads in tunnel differ from open roads and such differences require consideration. These include capital, operating and whole life costs, ventilation, lighting and maintenance requirements. The nature and mix of vehicles in the traffic flow will also affect the physical design of tunnels - flows with a higher percentage of HGVs requiring extra ventilation, especially at steeper gradients.

2.6 Value Management and Value Engineering, Risk Analysis and Management (Value for Money Manual: Highways Agency: June 1996) shall be used to consider alternative solutions to meet the needs and to evaluate the most appropriate options, noting that, in addition to construction costs, the particular location of the tunnel and the input from equipment manufacturers can influence ongoing maintenance and operational costs.

2.7 The four main stages in tunnel planning and design ie Feasibility Studies and Investigations; Planning; Agreement and Design , are shown in Figure 2.1.

Basis of Tunnel Operation

2.8 There are two broad categories of tunnel operation to be considered:

- i. Tunnels that have their own dedicated management structure and resources to operate the tunnel and which retain responsibility for traffic surveillance and the safe operation of the tunnel, including response to incidents and emergencies. This type of tunnel operation includes tunnels built under Acts of Parliament such as toll tunnels and the major estuarine crossings (Clyde, Dartford, Mersey, Tyne etc). The tunnel manager's responsibilities include the enforcement of any bye-laws concerning vehicles which carry dangerous goods.
- ii. Tunnels that are designed to operate as fully automatic facilities and do not entail the resources of permanent operating and monitoring staff. Tunnels on motorways and other trunk roads will generally be designed to operate in this way. It is policy for such tunnels to allow the free passage of dangerous goods vehicles operating within the law. To divert such vehicles off the motorway and trunk road system would transfer risk to locations that may not have facilities or ready access to deal with any emergency incident involving fire or spillage.

2.9 Adequate safeguards shall be in place before a tunnel is opened to the road user. Plant and equipment to control the tunnel environment, with provision for monitoring its status and notification of alarm states and potential emergencies shall be provided. All shall be

maintained at an acceptable level of public safety, economy and efficiency.

Safety

2.10 Safety in tunnels covers a wide range of issues. This section gives guidance on some of the important and more common issues to be considered but, together with the guidance elsewhere in this document, should not be considered to be exhaustive. It is important that the Overseeing Organisation's appointed person with overall responsibility for ensuring that the operational safety of a tunnel is maintained has sufficiently clear documentation made available to carry out his/her duties. For Highways Agency tunnels, the appointed person will normally be the relevant Network Area Manager.

2.11 In conjunction with the work of the TDSCG, the planning and designing engineers for the road tunnel must have a proper understanding of how the tunnel will be operated and ensure that there is adequate and safe provision for maintenance, economic running and operational safeguards. Each must be satisfied that all options concerning tunnel operating policy, such as the passage of hazardous goods, and tunnel planning, such as the locations of the traffic control centre and equipment for on-site, remote surveillance and control, are considered well in advance since there is little or no scope for subsequent physical alteration (eg changing ventilation shafts, emergency access, etc).

2.12 Operational and safety aspects have a significant effect on development of the detailed design, particularly of M&E functions. Preliminary proposals shall be based on adequate consultation with the Technical Approval Authority (TAA), Project Manager, Police, Emergency Authorities and the proposed Tunnel Operating Authority (TOA). For UK Government road tunnel schemes, and also where a Local Highway Authority requires, the TAA will be the appropriate person within the Highways Agency or Scottish Executive Development Department responsible for granting approval in principle, see BD2 (DMRB 1.1).

2.13 During the development of the design, the details of the systems and nature of equipment to meet the requirements and objectives of the BD2 (DMRB 1.1), Approval in Principle (AIP) submissions will become apparent, and any uncertainties in the preliminary studies will be gradually resolved. Regular meetings of the TDSCG will facilitate this process. At such meetings, the designers, TAA and parties having a necessary input into the design and safe operation of the tunnel, shall confirm the basis of the design and the

proposed scale of provision to the Police, Emergency Services and Tunnel Operating Authority, to allow them to commence their own planning.

2.14 BS 6164: Safety in Tunnelling in the Construction Industry provides guidance on safe practices within tunnelling works, including their maintenance and repair. For compressed air working the following regulation applies Work in Compressed Air Special Regulations 1958, SI 61 and the guidance contained in CIRIA Report 44: Medical Code of Practice for Work in Compressed Air: 1982.

2.15 The requirements of road safety audits are given in HD19 (DMRB 5.2.2) and accompanying advice in HA42 (DMRB 5.2.3). The agreed working party report from the TDSCG shall provide a substantial input to fulfilling the requirements of the Road Safety Auditor for the highways within and immediately adjacent to a road tunnel.

2.16 The Highways Agency have issued to their staff the following Health and Safety Notices with particular relevance to road tunnels: No 9 Working in Confined Spaces; No 10 Working in Tunnels; No 11 Staff Working with Lighting Equipment, Signing Equipment and Electrical Services on Roads and in Tunnels.

2.17 The Health & Safety Executive produce a document EH40: Occupational Exposure Limits, which is regularly updated, and gives guidance and legal requirements for the limits of harmful substances to which employees may be exposed. Chapter 5 gives requirements for road users. For those at work in tunnels, at any time, the more common hazards include carbon monoxide, oxides of nitrogen, benzene, particulates and dust. Mechanical ventilation, if provided, shall be used to purge the tunnel with clean air before any authorised persons enter the tunnel. For naturally ventilated tunnels, the polluted air shall be allowed to clear sufficiently for satisfactory personal gas monitor readings to be established before any authorised persons shall enter the tunnel.

2.18 BS 7671 IEE Wiring Regulations shall be complied with to meet the requirements of the Electricity at Work Act: 1979, in particular the requirements of Regulation 4(4) of the Act which require regular electrical testing to be carried out. For external highway power supplies eg to street lighting and traffic signals this period is every 6 years. For fire alarms (BS 5839) and emergency lighting (BS 5266) the cycle of testing is every one and three years respectively. Other tunnel equipment shall be tested at frequencies laid down by the equipment designer/supplier in accordance with the

relevant British Standards and as recorded in the planned maintenance sections of the Tunnel Operation and Maintenance Manual. Such frequencies of inspection and testing shall be regarded as the minimum standard to apply and shall be increased, if necessary, in the light of operational experience.

2.19 Measures shall be taken, and regularly maintained, to minimise the risk of any rockfalls, landslips etc from endangering the safety of road users and bystanders within open cut approaches and portal areas of road tunnels.

Incidents and Emergencies

2.20 Two broad situations influence the planning for emergencies. The more common event is a vehicle incident or breakdown which causes a degree of lane blockage, and consequential restriction or even temporary loss of use of the tunnel. The resulting delays may rapidly extend to the surrounding road network. Prompt remedial action is then called for to restore free flow and minimise the congested conditions that in themselves can aggravate the risk of further breakdown and/or incidents. The second situation involves collision and possible fire or explosion and is potentially more dangerous for the tunnel user and requires a rapid response from the emergency services.

Risk Analysis and Management

2.21 Refer, for general guidance, to the Value for Money Manual: Highways Agency: June 1996: Stationery Office. For a particular tunnel, potential hazards must be identified and related to the tunnel layout and to standards of equipping, communications, and traffic information and control systems. Such standards of provision shall meet the needs of the operators for the day to day running of the tunnel, and the emergency services in their response to tunnel incidents, including fire. Special attention shall be given to aspects that affect driver behaviour eg signing, signalling, traffic movements in the tunnel and on the tunnel approaches.

2.22 The selected tunnel cross section shall be carefully related to the approach road standards, geometry and visibility and procedures for dealing with incidents. Limited data available suggests that the tunnel approach, entrance and exit zones have a higher level of risk than the open road. Conversely, the tunnel interior has a lower level of traffic incident risk. For increased safety, verge widths over and above the minimum carriageway requirements for traffic flow, shall be

related to traffic demand and speed. Full consideration shall be given to cross connections between tunnel bores or alternative means of escape for vehicle occupants and to vehicular cross overs, outside the tunnel portals, for the purposes of contra flow and emergency access.

2.23 Fires or the spillage of hazardous materials are of greater consequence in tunnels than on the open road and proper safeguards must be based on an assessment of the risk implications of traffic carrying dangerous loads (explosives, flammables, radioactives and toxins). The decisions made shall be fully taken account of for the structure design, basic equipping and operating criteria (to include adequate fire protection) and ventilation capacity for fire and smoke control, and amply proportioning drainage sumps to cope with spillages of hazardous material and any sluicing water, foams, etc applied. Such safeguards as fire protection, ventilation and drainage shall also be considered in relation to pipelines carrying gas or chemicals belonging to third party users. A major international research project by PIARC/OECD is under way to provide guidance (<http://www.oecd.org/dsti/sti/transport/road>) on the transport of dangerous goods through road tunnels.

2.24 Consideration shall be given to the means of managing traffic under total power failure conditions. It should be expected to close the tunnel to traffic if both the normal power supply and standby, to power lighting and variable message signs, fail. If standby power is brought into use at a level lower than for normal power, then speed control must also function to reduce traffic speed, so that the risk of an accident occurring is minimised.

2.25 Availability and security of power supply shall be assessed, and unless complete reliability, in all but very exceptional circumstances, can be guaranteed by the supply authority, an alternative source shall be provided for essential safety related services.

2.26 The likely risk scenarios which may occur in and on the approaches to the tunnel shall be identified. These shall be considered in detail with the appropriate parties, and engineering solutions developed by the Design Organisation when appointed, for all relevant areas of the tunnel and its approaches. A possible methodology to systematically deal with risk is shown in Tables 2.1 to 2.4. Risk scenarios include, but are not limited to:

i. Vehicle related incidents:

- Fire in tunnel
- Accidents
- Breakdowns

- Debris on road
Overheight vehicles.
- ii. Non vehicle related incidents:
 - Lighting failure
 - Ventilation failure
 - Pumping failure
 - Telephones out of order
 - Pedestrians in the tunnel
 - Animals in the tunnel
 - Vandalism
 - Terrorist attack.
- iii. Traffic queues:
 - Traffic queues due to other causes eg volume of traffic.
- iv. Vehicle loadings:
 - Hazardous loads
 - Slow moving loads
 - Wide loads
 - Abnormal Indivisible Loads.
- v. Weather hazards:
 - Fog
 - Rapid, air vapour condensation on windscreen, mirrors etc
 - High winds
 - Ice
 - Snow
 - Flood
 - Dazzle from the sun (particularly east to west tunnel alignments)
- vi. Planned maintenance:
 - Lane closures
 - Carriageway closures
 - Tunnel bore closures
 - Total closure
 - Contraflow operation
 - Temporary signing.

2.27 Having identified and defined the scenarios, strategies for dealing with them shall be decided taking consideration of the management, coordination,

operation, mobilisation, access, procedures and communications requirements of the various parties involved and the needs of the road user. Consideration needs to be given to the level of human resources required during an incident, both at the control centre and on the ground. Response strategies shall deal with the initial occurrence of a situation and also any resulting developments, for example, a breakdown in a tunnel may lead to initial local queuing which may develop into wider scale area congestion and gridlock.

Classification and Decisions on Safety Facilities

2.28 Criteria for, and the related expenditure on equipping road tunnels shall be related as closely as possible to the particular needs at individual sites. The basis of equipping and operating tunnels therefore uses a classification system for tunnel type on motorways and sub divisions of all purpose roads.

2.29 From the strategy decisions and incident scenario considerations it will become clear as to what type of equipment and systems are necessary and also what the interaction between systems should be. It should also be possible to identify the necessary levels of information flow between the parties involved, which will determine the technical links and communication facilities needed.

2.30 Once the equipment and systems involved have been determined, technical specification can be carried out. The necessary communication infrastructure can also be determined and specified once the equipment and system needs are understood.

Traffic Management

2.31 Current road policies and design standards contribute to a reduction in accidents and, by way of through routeing, particularly for heavy goods traffic, improve local traffic management and control in new highway schemes. These objectives shall be maintained when selecting the criteria on which to base the design and operation of a road tunnel.

2.32 Traffic management shall cater for normal traffic flow and for special movements, planned and emergency maintenance and emergency incidents.

Restriction on Tunnel Use

2.33 For safety reasons, restrictions are necessary for the type of traffic permitted to use a road tunnel. Pedestrians, pedal cycles, motor cycles with engines less than 50cc, animals and animal drawn vehicles,

pedestrian controlled vehicles and invalid carriages should not be permitted. Such classes of road users are currently prohibited from motorways and unless there are very exceptional circumstances they should also be prohibited from trunk road tunnels. Consideration shall be given to the provision of alternative routes, where necessary, see also TD36 (DMRB 6.3.1).

Speed Limits

2.34 The imposition and, in particular, enforcement of speed limits within road tunnels on the open highway requires careful consideration. The costs of construction and operation of a tunnel designed to meet the geometric standards of the adjacent open road may lead to pressures to adopt a marginally lower design speed within the tunnel. There is little evidence to support propositions that traffic will naturally tend to slow at the entry to a tunnel and only to speed up inside, if conditions permit. Any such assumptions would need to be confirmed by monitoring once the tunnel is open to traffic - it may then be too late to make the necessary modifications if such assumptions proved to be false. See Chapter 4.

Establishment of Tunnel Profile

2.35 It is important, for informed design progress on other aspects of the road tunnel design, to establish the location, cross sectional shape and gradient profiles for the tunnel as early as possible in the planning process. See Figures 2.2, 2.3, 4.2 and 4.3 for typical cross sectional profiles. The most desirable profile for accommodating road traffic containing HGVs is rectangular.

2.36 In certain situations planning constraints may well determine tunnel location and consequent choice of construction method. Ground conditions and appropriate choice of tunnel construction method are important factors determining the structural form of a road tunnel. Tunnel cross sectional shape profile for a given traffic space, and the consequent space available for tunnel equipment, is largely determined by the most economical method of construction, which in turn depends on construction access, depth of tunnel, the nature of the ground and its stability during excavation.

Consideration of Future Widening and Maintenance Lanes

2.37 It is not normally possible to widen a road tunnel structure to cater for a future increase in the number of

traffic lanes required. It may be possible to increase the number of traffic lanes by one, if the existing traffic lanes are narrowed, or the hard shoulder, if any, is replaced. Consideration shall be given to minimising the potential increase in risk of traffic accidents, reduced emergency access and egress, and to cater for any additional ventilation and headroom requirements that such widening will require. Similarly, if tunnel closure periods for maintenance are anticipated to be of limited availability a marginally wider tunnel may be decided upon so that the safety zone requirements of Chapter 8 of the Traffic Signs Manual: Traffic Safety Measures and Signs for Roadworks and Temporary Situations: SO can be accommodated. A study of the anticipated traffic peak flow, tidal flow and hourly demand variations is necessary. A possible option to consider is whether, for example, three 2 lane tunnel bores would be better than two 3 lane bores. The former has the advantages, particularly for uneven traffic flows, of option to close one bore in quieter periods for more effective maintenance, traffic management flexibility and reduced congestion effect should there be an incident in one bore. Effective foresight and provision for such needs will reduce the additional costs and disruption to a minimum.

Service Tunnels, Space Requirements

2.38 Where land availability and funding permit and planned maintenance constraints make desirable, then a separate service tunnel, adjacent to the live traffic tunnels, should be considered on a whole life cost basis, for providing access on maintenance demand to service cabling and other operating equipment, without requiring a tunnel closure. Such tunnels may also be used for evacuation purposes during an emergency. Other advantages include their use as an exploratory (pilot) tunnel in advance of main tunnel construction.

Driven Tunnels Profiles

2.39 Driven tunnel profiles in rock which may be excavated using eg drill and blast or boom cutter techniques, are mainly dependent on the shape required for the stability of the excavation during its temporary stages. Other rock tunnels using full face machines normally have circular cross sections. Circular cross sections are not well suited for the ideally rectangular shape of road tunnels. Tunnels lying in, or partially in, soft ground are often driven with a shield and will be circular or part circular. Driven tunnels using full face machines normally have circular cross-sections, whilst part face tunnelling machines are less restrictive in shape.

Cut and Cover Tunnel Profiles

2.40 Cut and cover tunnels are generally rectangular with a clear headroom close to the structure gauge.

Immersed Tube Tunnel Profiles

2.41 Immersed tube tunnels are usually rectangular in section and constructed in reinforced or prestressed concrete. These may be provided with separate cells for use as buoyancy during placement and subsequently for tunnel services. In steel/concrete composite construction such tunnels are sometimes circular or part circular in shape.

Space for Equipment

2.42 The space between the equipment gauge and the profile set by the structural lining or secondary cladding of the tunnel is available for the equipment required for the tunnel environment. Such space shall be used efficiently to suit the equipment required, otherwise any enlargement of the tunnel cross-section will lead to significant increase in cost. In rectangular tunnels, the upper corners might be haunched to benefit structural efficiency but possibly cause a disbenefit in regard to the space and optimal location of equipment.

2.43 Care shall be taken to identify the optimum positions for electrical and mechanical equipment located in the tunnel, since ease of access can have a significant effect on ongoing maintenance costs and the number of traffic lanes requiring closure.

Ventilation Space Requirements

2.44 Ventilation can have a considerable influence on space requirements, depending on the system chosen.

2.45 It is important for tunnels to be as aerodynamically efficient as possible. Naturally and mechanically ventilated tunnels, with one way traffic, partly rely for ventilation upon the vehicle induced air flow. This effect can be maximised, for a given size of tunnel, if the tunnel interior surface is as smooth as possible and abrupt changes in cross-section, particularly at air entry/exit points are avoided.

2.46 In the event of a fire within a tunnel, the hot air and smoke will form a layer at ceiling level, moving outwards from the source and leaving a zone of clear air beneath it for a distance either side of the source. Downstands from the ceiling and other obstructions which might break up this layer and prematurely fill the tunnel

with smoke, obstructing escape and rescue, shall be avoided.

2.47 Ducted ventilation systems may have shafts and adits connecting fan rooms to the main ducts within the tunnel. These shall be as smooth as possible and any bends or junctions be as aerodynamically efficient as possible.

2.48 Space requirements for longitudinal ventilation, using booster (jet) fans normally has little effect on the geometry of arch roofed tunnels providing the fan diameters are kept below 1.5m diameter. The fans should be placed over the carriageway lanes within the equipment gauge, rather than above the verges. In the case of rectangular tunnels, one solution is to increase the height of the tunnel over its full or partial length to accommodate the fans. Where constraints or increased construction costs preclude this solution, fans can be placed in aerodynamically shaped recesses (niches) in the soffit or at the tops of the side walls. However ventilation efficiency may be reduced and significantly so for the latter. The life time additional costs from such efficiency losses shall be established before deciding on the profile to be adopted.

2.49 Space requirements for transverse and semi-transverse ventilation systems normally have little influence on arched or circular tunnel geometry, as these generally contain space above or below the road deck which can be used for ventilation ducts. However, where large volumes of ventilation air are required, an increase in structure size may be required. In the case of rectangular profiles such systems have an important effect on tunnel geometry, sometimes requiring a greater height of tunnel and sometimes increased width. In all types of tunnel these systems of ventilation require ancillary shafts and/or tunnels and ventilation fan buildings. The buildings and their intake and exhaust structures and emissions may have important environmental consequences. Their location, if not ideal, can significantly affect ventilation space requirements within the tunnel.

Lighting Space Requirements

2.50 Generally tunnel lighting has little bearing on the tunnel geometry. In arched roof profiles, without false ceilings or ventilation duct soffits, there is normally ample space for luminaires. Only arched tunnels with false ceilings and rectangular profiled tunnels, where the luminaires are located above the traffic lanes, require vertical space of between 350mm and 500mm to accommodate the 250mm additional clearance and the luminaires themselves.

Signs and Signals Space Requirements

2.51 Signalling equipment, if located on the side walls, has little influence on the cross section of arched tunnels, with two lanes, or of rectangular tunnels.

2.52 For tunnels with more than two lanes and having a false ceiling or rectangular profile and where the signalling equipment is fitted over the traffic lanes, about 350mm vertical height is needed.

2.53 Full sized direction signs are difficult to locate within a tunnel and are best positioned outside of the portals.

Toll Booth Space Requirements

2.54 Where tolls are to be collected as cash the provision of toll booths will be necessary. The number and siting of these will be dictated by their effect on traffic flow in the tunnel and on land availability, which will vary from site to site. Toll booths may be situated at one or both ends of the tunnel, or series of tunnels. Collection and control is by a mix of manual methods, coin receptacle from a moving vehicle or electronic tagging with prepayment. Booths will require heating, ventilation, till, seating, signing, communication and security facilities and protection against impact from vehicles and robbery. Air conditioning may be required, see Chapter 5.

Tunnel Services Buildings, Tunnel Portals: Land and Royal Fine Art Commission /Commission for Architecture and the Built Environment Requirements

2.55 Services Buildings to house the substation, plant room, control centre, etc. will normally be required. Their location will be dictated by the requirements of the electrical distribution system (ie as close as possible to the tunnel to avoid excessive voltage drop), by the type of ventilation system and by land availability.

2.56 Services Buildings are part of the complete tunnel and highway scheme and are not treated as a separate development. The buildings and tunnel portal areas, particularly for a major scheme, or one in an Area of Outstanding Natural Beauty or near listed buildings or conservation areas may need referral to the Royal Fine Art Commission (RFAC). RFAC is to be replaced by CABE, the Commission for Architecture and the Built Environment. The Overseeing Organisation shall consult the Highways Agency Architect on the need to refer details of the proposed service buildings and tunnel portals for

the comment of the Royal Fine Art Commission, and inform the appropriate Design Organisation accordingly. In Scotland the Scottish Executive Development Department shall be consulted regarding the requirement for submissions to the Royal Fine Arts Commission for Scotland.

2.57 The need for a tunnel services building to fit into its surroundings shall not result in the provision of less than adequate space for housing necessary equipment. Consideration shall be given to the need for adequate ventilation and air conditioning to avoid excessive room temperature, particularly in UPS rooms, battery rooms and areas containing electronic equipment. Service buildings shall be located clear of any road drainage sumps because of the inherent dangers of electrical equipment in close proximity to explosive gases from spills etc. For habitable buildings, the requirements of the Building Regulations, Fire Regulations etc apply.

Secondary Cladding Function and Space Requirements

2.58 Where secondary cladding is to be provided it usually constitutes an additional layer of lightweight construction, placed over the internal face of the primary (main load bearing) lining. The main functions of secondary cladding are to provide a reflective surface to assist tunnel lighting; to smooth the interior of the tunnel to facilitate mechanical cleaning of the tunnel walls; to reduce ventilation energy losses and to shed drips to drainage in the case of seepage through the primary tunnel lining. It also may provide a beneficial effect, where anti-drumming layers are added, on noise levels within the tunnel. Where the secondary cladding is used to blank off dead space within the tunnel, it has minimal effect on the cross section. The lower part of the tunnel wall shall be designed to minimise the risk of traffic collision with the secondary cladding. Internal finishes to the tunnel structure, visible to the travelling public, shall be attractive and functional without being distracting to safe driving.

Cabling and Ducted Services Space Requirements

2.59 The duct space required for the distribution and fire protection of cabling for tunnel M&E functions and possible future services must be determined at an early stage because of the significant structural influence that provision of such space can have on certain types of tunnel. Where secondary cladding is used, it may be possible to utilise the space between cladding and main structure for services, this will normally have to be designed into the original concept.

2.60 In long tunnels, de-rating of cables and pressure drop in piped services can lead to an increased size of

these services, and the need for larger ducts to house them. In circular tunnels, duct space is usually available under the roadway by virtue of the tunnel shape. In flat bottom shaped tunnels, however, an increase in depth is usually required to locate the cabling and/or pipework beneath the walkway zone. Placement of manhole and other duct covers within the traffic lanes shall be avoided as planned access to maintain, replace loosened covers etc may only be available during a tunnel closure.

Utilities

2.61 The construction of a road tunnel often offers opportunities to owners of utilities and communication companies to seek to use the tunnel to carry additional service pipelines, transmitters and cables for the benefit of such companies and their customers. It is left to the Overseeing Organisation to consult with the relevant Tunnel Operating Authority to decide which, if any, such additional pipelines and cables may be accommodated. Points to consider include the effect on tunnel safety, operations and maintenance; access to effect repairs; liability for any curtailing of or damage to services; fire or explosion from eg gas leaks; corrosion and heat from high voltage cables; ventilation energy loss from the additional drag caused by the larger diameter pipelines; interference with broadcasting of the emergency and maintenance staff broadcasting frequencies; the need to discourage use of mobile telephones whilst driving within a tunnel; and competition policy. The development of in-car communications could be of significant benefit to contact and guide road users during a tunnel emergency. Rental levels shall be set sufficiently high to cover fully such costs and risks, and fully include, pro rata, for the alternative costs the utilities etc would need to bear if the road tunnel were not available, as well as an agreed share of the continued income from the provision of such services. Legal advice shall be sought by the Overseeing Organisation on any rights of Statutory Undertakers and Public Utility service providers relevant to services in a public highway, where the public highway passes through a road tunnel.

General Design Considerations and Requirements

2.62 Elsewhere in this document, more detailed tunnel design considerations and requirements are provided for aspects of road tunnel schemes which have reached a more advanced stage of development. Issues involved, however, are not necessarily limited to those that have been described.

2.63 The Overseeing Organisation responsible for commissioning highway projects shall ensure that the

planning and design considerations for road tunnels are carried out in consultation with appropriate and experienced design specialists. The specialists shall consider all design, operations and maintenance implications for the tunnel and its associated infrastructure. If the responsibility for maintenance is passed to a third party, appropriate standards must also be agreed by the parties concerned.

2.64 It shall be recognised that the construction and operation of road tunnels is often one of the most costly aspects of all highway structure provision. Every effort shall be made to minimise such costs, whilst providing a safe and reliable facility for the road user.

2.65 For mechanical and electrical (M&E) plant and equipment that is to be installed, much of the detailed design will be undertaken by the manufacturers appointed by the successful Contractor and undertaken in accordance with the requirements of the contract specification. Contract documentation will need to contain a clear presentation of design, maintenance and operational requirements, including the interfaces with other equipment etc.

2.66 Where design under the (construction) Contract is required, the requisite information is usually provided in the invitation to tenderers and, depending on the type of contract employed may be either a basic design of the tunnel layout and geometry, together with the plant and equipment that is to be installed, or, in the case of design and build forms of contract, take the form of Employers Requirements, with the additional option of including an Illustrative Design of core requirements.

2.67 The final design should be the outcome of a balanced and coordinated response to the needs and circumstances applying at individual road tunnel sites, the requirements of relevant Authorities consulted and the views of the TDSCG.

2.68 The five key elements of a road tunnel design or refurbishment normally relate to:

- i. For a new tunnel, the tunnel profile and protection of the tunnel structure against accidental damage, such as fire from vehicle collisions or spills.
- ii. The role and extent of the equipment and plant that is required to monitor, communicate and control the tunnel environment and respond to tunnel emergencies. The level of future maintenance and operational costs are closely correlated to the level of installation of such equipment and plant.

- iii. Whether the tunnel is to be permanently manned or operated remotely.
- iv. The tunnel maintenance and operating procedures required to facilitate day to day operation and to respond to emergency conditions.
- v. The number and duration of tunnel closures during which preventative and corrective maintenance works can be efficiently carried out. It is essential that the designer makes every effort to minimise the need and efforts required for and during such works.

2.69 Virtual Reality modelling, by computer, of the tunnel design and construction stages, equipment positions and maintenance/spares/performance history, operation phases and planned and emergency closures and training are considered, with the continued reduction in processing costs, to offer considerable benefits in terms of communications and decision making for all parties contributing to the successful design, construction and operation of a road tunnel. The earlier that such modelling is introduced into the procurement and operation process the greater are the potential benefits. The requirement for Virtual Reality modelling for a particular project shall be confirmed by the Overseeing Organisation.

2.70 BD2 (DMRB 1.1) gives the requirements for technical approval of the road tunnel structure and equipment. Compliance with statutory requirements and recognised Standards and Codes, including appropriate sections of the Design Manual for Roads and Bridges, shall be managed within an approved quality system to cover all phases and aspects of the project.

2.71 BD31 (DMRB 2.2), (in Scotland SB3/88) does not apply to road tunnel designs. For site investigation requirements refer to HD13 (DMRB 4.1), HD22 (DMRB 4.1.2), (in Scotland, SH4/89), HA34 (DMRB 4.1) and HA73 (DMRB 4.1.7). For "cut and cover" type road tunnels the guidance of BD42 (DMRB 2.1.2) applies for the design of any embedded walls including secant piled walls. An Advice Note BA80 (DMRB 2.1.7) on the design of rock bolts is now published. Design to mitigate against heave loadings and displacements at the tunnel road base slab shall be undertaken from first principles. For structures vulnerable to thaumasite sulfate attack the advice and guidance contained in IAN 15 (DMRB 2.1) and the report of the Thaumasite Expert Group: The Thaumasite Form of Attack: Risks, Diagnosis, Remedial Works and Guidance on New Construction: January 1999.

2.72 The range of settlements (vertical and horizontal), rotations and differential displacements that the likely tunnelling construction method, plant, expected rates of advance and changes to the water table level are likely to produce during and after tunnelling shall be estimated, and the likely effects on adjacent structures (including utilities) disclosed to, and agreed with, the owners. Where such estimated settlements place an unacceptable strain or displacement on the adjacent structures (including utilities) then agreed mitigation measures shall be proposed to limit such values to acceptable levels. Adjacent structure (including utilities) condition surveys shall be carried out prior to, during and after completion, of the tunnelling works, until any further settlements are of no account. The survey results shall be agreed at the time between the parties concerned. Measures to record and control tunnelling settlement shall be in place before construction commences, as shall rapidly activatable contingency measures, and shall be subject to continuous review.

2.73 The incorporation within the tunnel of materials which give off toxic fumes during a fire shall be avoided or otherwise minimised. The collection of traffic dust, which often contains toxic substances and is a potential fire risk, in areas difficult to clean on a regular basis, such as within false ceilings, shall be mitigated against. The use of asbestos products such as asbestos cement air duct formers and asbestos rope gaskets between tunnel lining segments shall not be permitted. The injection of materials into adjacent ground which may be of harm to the environment shall not be permitted.

2.74 Whilst road tunnels provide a drier and more sheltered environment for road users than the open road it shall be recognised that the atmosphere within a tunnel is often humid and polluted with dust and acidic gases from vehicle emissions. Such conditions could be harmful to maintenance staff, unless safe working procedures are adhered to, and are aggressively corrosive to any equipment installed within the tunnel. Chlorides, particularly from the use of road salt, have also caused considerable damage to several UK tunnel structures and equipment and alternative, less damaging, de-icing materials shall be considered for application, limited to the actual need, within and close to tunnel sections of the highway. Consideration of de-icing materials shall be undertaken by the Design Organisation at the design stage and shall be appropriate for the environment and the tunnel structural and equipment materials proposed. Protection to reinforced concrete elements is detailed in BD43 (DMRB 2.4) and BD47

(DMRB 2.3.4). Solutions to wash tunnel walls to maintain light reflectance are often caustic in nature. The effect on structure and component durability as well as Health and Safety aspects shall be considered by the Design Organisation and the appropriate materials used. Stainless steel grades believed to be resistant to such environments include BS1449 316S13, S16 and S33, which contain in excess of 2% molybdenum. Further advice is contained in Appendix B.

2.75 Water leakage into tunnels through structural cracks and joints can be hazardous when flow collects in areas with, for example, high voltage cables and other electrical equipment such as tunnel lighting. Freezing of the water may lead to areas dangerous to the travelling public and tunnel maintenance staff, thawing may lead to hazards such as icicles falling on to road users from the tunnel roof and portals, as well as increasing the rate of deterioration of the structure, particularly around the regions of inflow at cracks and open joints. Exposed leaks are unsightly and may alarm the public as to the safety of the tunnel structure. Heavy leakage is costly in energy terms, if additional pumping out of the roadway sumps is required. Any associated lowering of the ground water table may be environmentally detrimental and/or lead to settlements of adjacent structures.

2.76 Where tunnels lie totally or partially below the water table or are in ground subject to water flows, the tunnel structure designer and tunnel constructor shall take all reasonable measures (eg controlled collection and discharge of ground water) to reduce the possibilities of water leakage through and into a road tunnel structure for the whole of its 120 year design life. Tunnels where any joint or crack is weeping at handover to the Overseeing Organisation shall not be accepted and effective remedial sealing works shall be undertaken. Where leakage has been successfully sealed then provisions shall be made so that re-sealing of the defect or sealed joint is readily effected should leakage reoccur during the design life of the tunnel structure. Sealing or resealing shall not reduce the effectiveness of any internal or external drainage system provided. CIRIA Report 81: Tunnel Waterproofing (now withdrawn) provided a discussion on the principals to be considered. Any product, method or material proposed for waterproofing or sealing a road tunnel structure that does not have a proven record of satisfactory service within road tunnels, to the satisfaction of the Overseeing Organisation, shall be subject to comprehensive and successful trials, off the tunnel site, before its adoption may be considered for approval. BD47 (DMRB 2.3.4) and BA47 (DMRB

2.3.5) apply to the waterproofing and surfacing of suspended road tunnel decks.

2.77 All installed software and hardware components and systems, embedded or otherwise, provided at, or linked to, a road tunnel, which are critical for the safety of the travelling public or to the reliability of continuous operation of the tunnel shall be designed and certified, as checked and tested, that no value of a current date, in the future, will cause any interruption or false output to their operation. Year 2000 conformity shall be to DISCPD2000-1 (BSI).

2.78 Where buildings or other developments are planned to be constructed over, or adjacent to, road tunnels then account shall be taken, in the tunnel design or assessment, of the additional loading to be imposed (or equivalent uniformly distributed loading) and the construction methods such as piling, excavation, ground anchoring, ground water lowering, diversion of services etc which could be reasonably expected to take place in the construction and use of such developments. A “build over” document shall be prepared by the Design Organisation defining the parameters, effecting the loading condition of the tunnel, within which the “build over” developer is constrained to comply. Technical approval of any “build over” proposals, including existing road tunnels, shall be carried out to BD2 (DMRB 1.1). It is important to use a consistent approach throughout, for both tunnel and “build over” for partial factors concerning loading, materials and section design assessment. Road tunnel structures of concrete and/or steel shall be designed to the DMRB requirements of BS5400. The Overseeing Organisation shall instruct the Design Organisation on the need for such allowances for “build over”.

2.79 Air pollution, arising from the vehicles passing through a road tunnel, is concentrated and exhausted at the tunnel portals and any ventilation shafts. For environmental reasons, in locations with adjacent inhabited buildings, it may be necessary to provide additional forced ventilation so that the polluted air being expelled has sufficient velocity and turbulence to mix and distribute with the ambient air, so that ambient air pollution regulation levels are not exceeded. It will normally be necessary, in such cases, to establish the average background level of the ambient air pollution at an early stage. For site readings, exhausted air from the tunnel shall be measured at the nearest inhabited building which is not part of the tunnel operation or 100 m from the portal or the point of issue, whichever is

the lesser. PIARC (Road Tunnels: Emissions, Ventilation, Environment: 1995) have published mathematical formulae to estimate tunnel dispersion distances, but physical scale models are presently believed to be more reliable for predictions in areas of complex topography and infrastructure.

2.80 Highway loadings, over and through a road tunnel, are as described in BD37 (DMRB 1.3). For cases such as transverse spanning, suspended road decks and road slabs supported on the ground, where it is not possible to determine the effective loading lengths for HA udl (uniformly distributed loading), then the vehicle loadings given in BD21 (DMRB 3.4.3): Appendix D shall be used. For design (as opposed to assessment) the loadings of BD21 (DMRB 3.4.3): Appendix D shall be increased by 10%. The Overseeing Organisation will

provide details of any Abnormal Indivisible Loading (AIL) vehicles to be included in design or assessment.

2.81 The internal walls, claddings and false ceilings etc of a road tunnel shall be designed for an additional operational loading due to the wind pressures and 'suctions' caused by the moving vehicle traffic. Nominal loadings to be used for preliminary design are +/- 1.5KPa, applied in the combinations for wind loads as defined in BD37 (DMRB 1.3). Such nominal loading values shall be reviewed for adequacy with respect to the traffic speed and range of vehicle heights, once the tunnel cross section and lining clearances become determined, and for any contraflow traffic operations. Any necessary redesign resulting from the review shall be undertaken. For fatigue on metal elements within cladding the stress cycle value shall be taken as 50 million.

Description	Scenario	Probability	Score
Highly likely	Very frequent occurrence	Over 85%	16
Likely	More than evens chance	51 - 85%	12
Fairly likely	Occurs quite often	21 -50%	8
Unlikely	Could happen but not very often	1-20%	4
Very unlikely	Occurrence is not expected to happen	Less than 1 - 0.01%	2
Extremely unlikely	Just possible but very surprising	Less than 0.01%	1

Note: Intermediate values may be interpolated.

Table 2.1 Event Probability

Description	Scenario Examples	Score
Disastrous	Tunnel operation could not be sustained	1000
Severe	Serious threat to tunnel operation	100
Substantial	Increases operational costs/difficulties substantially	20
Marginal	Small effect on operational cost/difficulty	3
Negligible	Trivial effect	1

Note: Intermediate values may be interpolated.

Table 2.2 Event Impact

Risk Priority Number (RPN)	Category	Action Required
Over 1000	Intolerable	Eliminate risk
101 -1000	Undesirable	Avoid or transfer risk
21 - 100	Acceptable	Retain and manage risk by prevention or mitigation
Below 20	Negligible	Could be ignored

Note: Identified risk scenarios should be ranked in RPN reverse order.

Table 2.3 Risk Priority Numbers (Event probability x Event Impact)

Risk Action Required	Possible Response
Elimination	Change provision such that risk cannot occur
Avoidance	Modify provision so that risk is greatly reduced
Transfer	Not likely to be able to do this for safety aspects
Prevention	Action taken to prevent risk from occurring
Mitigation	Measures taken to reduce impact of risk if it were to occur
Acceptance	It is accepted a risk may occur but it is negligible or there are no cost effective solutions available

Note: Risk response strategies should be listed and recorded.

Table 2.4 Risk Response Strategies

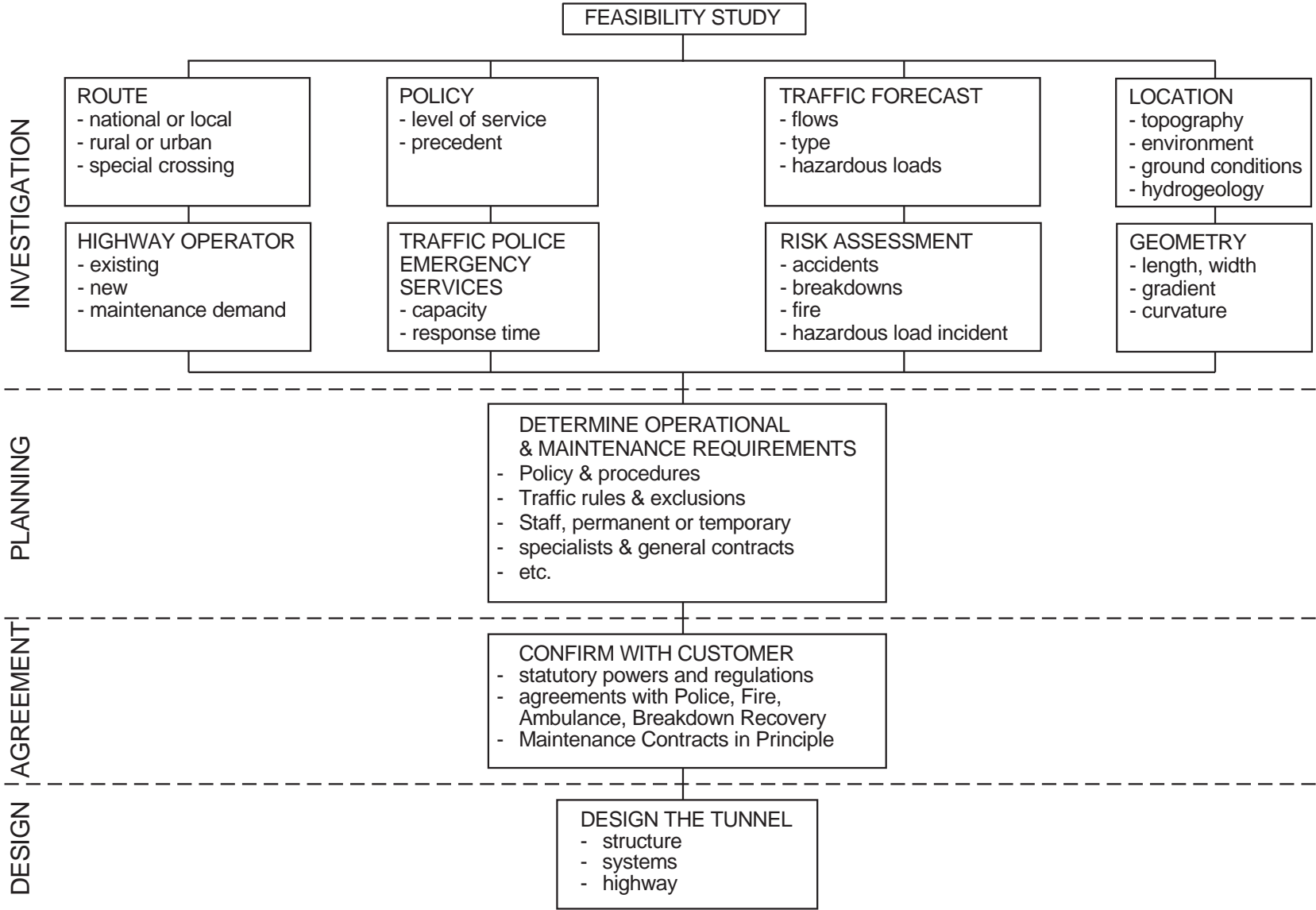

Figure 2.1

Tunnel Planning and Design Process

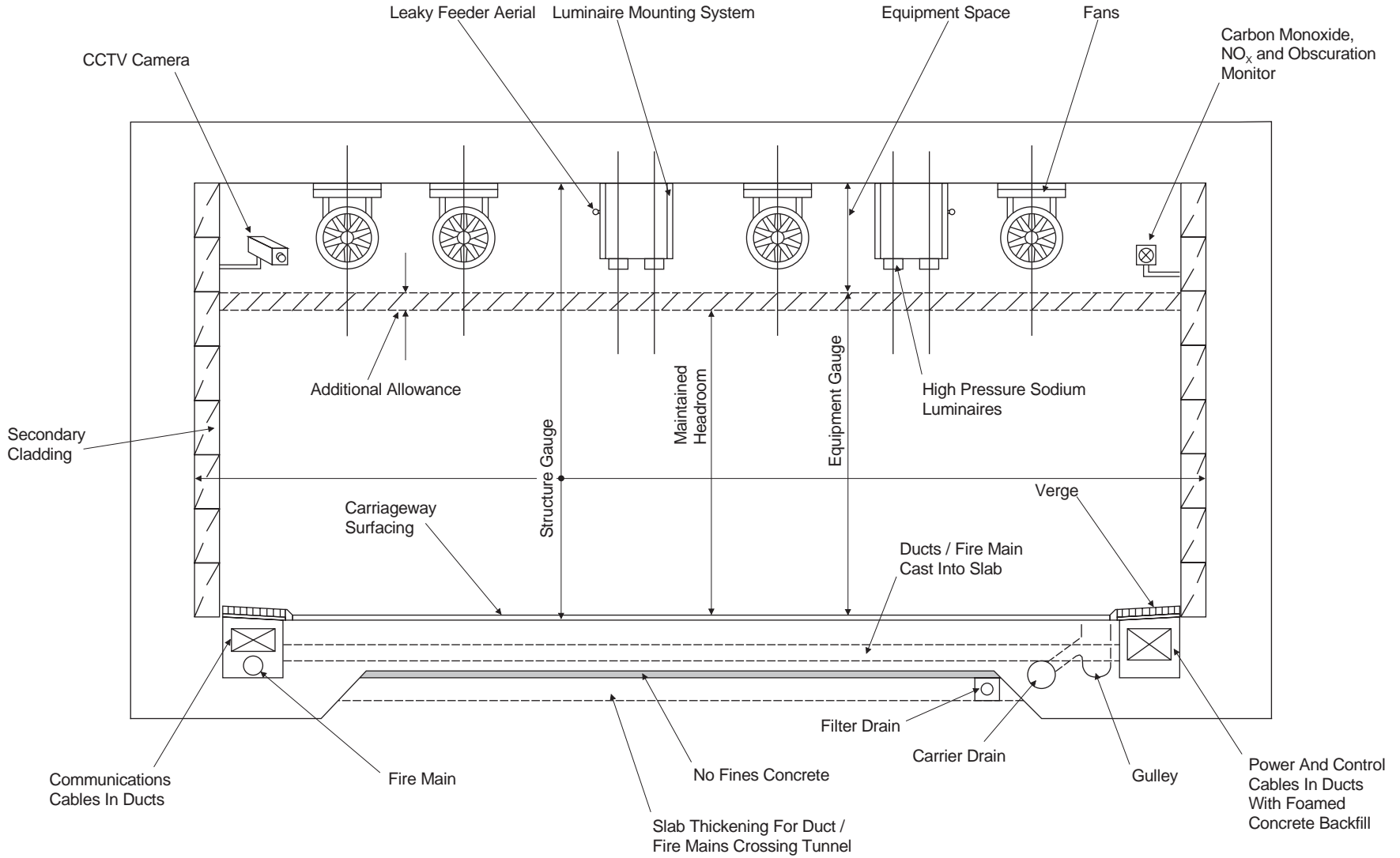
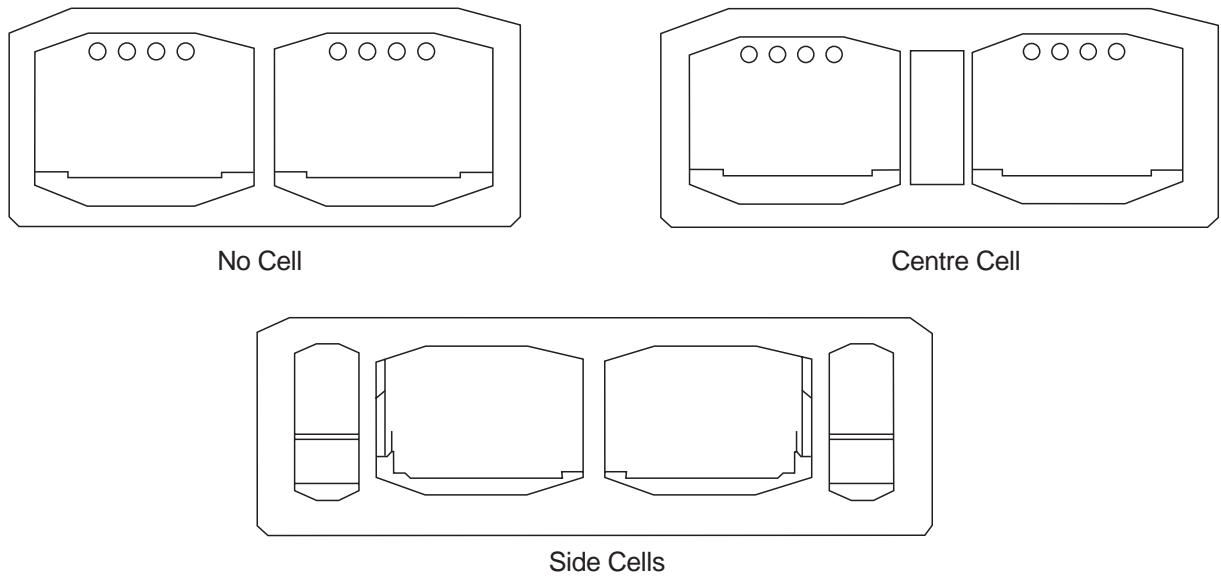
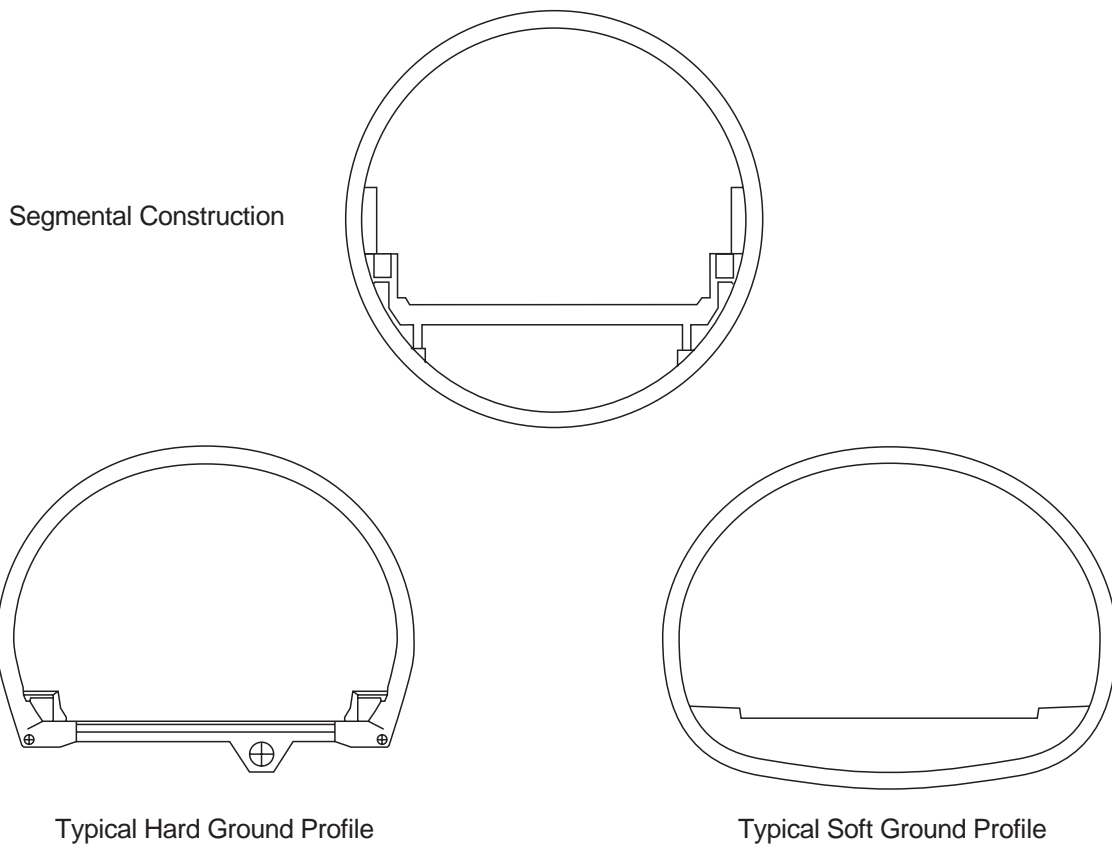

Figure 2.2

Typical Cut and Cover Tunnel Section
 (Looking In Direction Of Traffic Flow)



Immersed Tube Tunnels



Sprayed Concrete Tunnels

Figure 2.3 Typical Cross Sections of Bored Tunnels

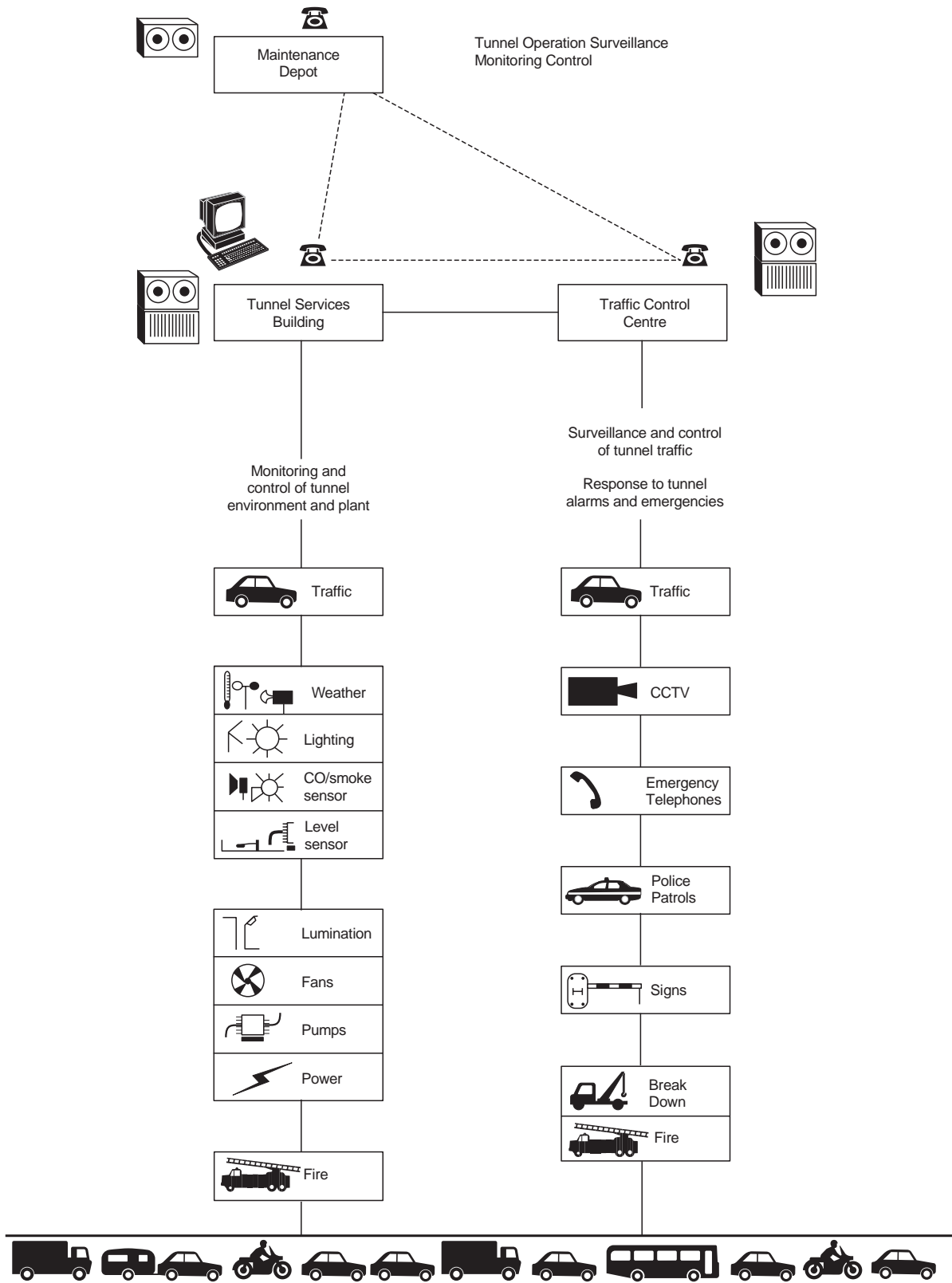

Figure 2.4 Basis of Tunnel Organisation

3. OPERATIONAL CLASSIFICATION OF SAFETY FACILITIES FOR THE ROAD USER

General

3.1 This Chapter describes the classification criteria for the selection of operational safety facilities to be provided in a particular road tunnel, such as space for emergency points, pedestrian access, escape routes, vehicle cross-overs and equipment relating to emergency points, ventilation override, traffic surveillance and control, communication and information systems. Where bye laws permit, road tunnels shall allow, and be appropriately equipped for, the free passage of vehicles legally carrying dangerous goods.

3.2 Any additional demands on a driver travelling through a road tunnel will vary between individuals and to a large extent, on the length of the tunnel and its structure and form. Those of a nervous disposition or suffering from certain phobias could, in some situations (eg very long tunnels or river crossings) find the experience daunting and in the extreme traumatic. Under normal free flow conditions, however, the majority of road users find little problem in driving through tunnels. Only in the event of vehicle breakdown, traffic congestion, or the rare occurrence of a serious accident, within the tunnel, will some experience unease or sensations of panic.

3.3 To mitigate such effects, clear communication and guidance shall be provided for tunnel users in the event of disruptions to the normal traffic flow such as maintenance, tunnel closures, diversions etc. In addition to the standard operating procedures devised for such events, and arrangements made for rapid response to accidents, breakdowns or other emergencies physical means of escape must be clearly indicated.

Basic Requirements

3.4 Facilities for operational safety must be considered for each tunnel in terms of its length, traffic conditions, and the type of road involved (ie motorway or other trunk road). This entails a review of the structural features affecting the tunnel layout, communications, response to emergencies, including fire, emergency lighting and the role of mechanical ventilation (where provided) in the event of a fire. In twin bore tunnels the unaffected bore offers the possibility of emergency services access, a refuge and an escape route.

It is also important to consider the tunnel with respect to the surrounding road network.

3.5 There are advantages in adopting a classification system to define the basic facilities to be provided for the operational safety of road tunnels (see Table 3.1). However, care must be taken to avoid misusing such systems, because no two tunnels are alike and the nature and variety of the safety issues involved requires that each tunnel be dealt with as a separate entity.

3.6 A tabulated system provides an effective means for conveying the key issues to non-specialists, particularly those employed in the general planning of tunnel projects. It also provides a basis for establishing preliminary design requirements and cost estimates.

3.7 At the stage when tunnel design and operational safety issues are being developed in more detail, a tabulated system of facilities provides a convenient framework for the TDSCG to ensure that systematic consideration is given to the specific safety issues at each site.

3.8 In matters relating to telecommunications and traffic control, only general guidance can be given, because the development of detailed design requirements in this area entails close cooperation with the Overseeing Organisation, in order to take account of relevant systems in place or planned on the surrounding network (NMCS etc).

3.9 The following traffic flow type and tunnel location factors shall be taken into account:

Unidirectional or bi-directional traffic flow within a tunnel bore

- i. This will affect the placement of emergency/distribution panels, traffic control measures and smoke control philosophy.

Urban or inter-urban location

- ii. Access and attendance times for the emergency services can vary considerably according to the location.

Location above or below water

- iii. Tunnels below the water table may be more susceptible to flooding and if passing under waterways the means of escape can only be via either end of the tunnel or into adjacent and unaffected tunnel bores.

Trunk road or Motorway

- iv. Traffic speeds and drivers' preparedness for possible obstructions will vary according to the criteria applying to the road of which the tunnel is part.

Classification of Facilities

3.10 The provision of safety facilities is related to the annual average daily traffic flow (AADT) for the tunnel design year, which is typically 15 years from the date of opening, and the length of the tunnel. Tunnels are separated into categories AA, A, B, C, D and E according to length AADT as shown in Figure 3.1. Categories for AADT in excess of 100,000 vehicles per day may be calculated by extrapolation of the graph.

3.11 Table 3.1 gives the recommended basic provisions for each category. The provisions should be regarded as a starting point for establishing design requirements rather than be rigidly adhered to if there are valid reasons not to do so. The requirements and considerations of tunnel layout, structural features, communications, emergency facilities, duplicate systems for reliability in operations and incidents, and value engineering all play a part in reaching the final decisions on provision.

Tunnel Layout and Structural Features

3.12 *Emergency Points:* Tunnel structures shall accommodate emergency points at intervals along the tunnel. Such points shall be large enough to house fire-fighting facilities and emergency roadside telephones connected to remote, permanently manned, police or tunnel control centres. The spacing of emergency points is determined by the requirements for spacing of emergency telephones, and fire hose reels and hydrants which shall be determined in consultation with the fire authority. The nominal spacing for emergency points is 50m, with emergency roadside telephones and fire hose reels (if fire brigade require) at every emergency point and hydrants at alternate points (ie at 100m intervals).

3.13 *Vehicle Refuges for Tunnel Incidents:* The initial cost of providing additional traffic space in the tunnel cross section to cope with incidents and breakdowns must be balanced against the operational needs of communications, surveillance, stand by recovery facilities, consequence of traffic delays and pressure on the surrounding road network. Such factors will depend on the length of tunnel, its location (rural, mountain, urban, sub aqueous) and on traffic demand. Advice from those experienced in the management of risks in road tunnels, rather than accident statistics, shall be sought to define the need for any additional traffic standing space.

3.14 *Emergency Stopping Lanes:* Due to the high costs involved there are very few examples of continuous emergency stopping lanes within tunnels. However, additional lane width or widened verges provide a temporary expedient for traffic to be able to pass a stranded vehicle. Such temporary provisions shall not be a basis for justifying traffic throughputs during prolonged periods of tunnel restriction. The first priority and whole basis of safe tunnel operation must always be to remove, as a matter of urgency, any obstacle to unrestricted lane use.

3.15 *Emergency Walkways:* Unobstructed pedestrian access, at low level, to emergency points shall be provided. [The high raised and protected walkways, which originated from the circular profiles of TBM (tunnel boring machine) constructed tunnels, give rise to distinct disadvantages: the loss of temporary standing for stranded vehicles; for drivers, the unwelcome side wall effect (avoidance) influencing driver behaviour; restricting the nearside opening of doors of stranded vehicles; loss of ready access to the emergency points and cross tube connections for all tunnel users, especially the disabled. Maintenance is also more problematical (eg duct walls, rapid deterioration of hand railing and general cleaning difficulties)].

3.16 *Escape Routes:* In twin bore tunnels, passenger escape routes through fire doors positioned in central walls or cross-connecting passages, shall be provided. These shall be positioned at 100m nominal intervals and provided with permanently lit signs, emergency roadside telephones etc. Single bore tunnel escape route and safe refuge requirements shall be examined and established by the Design Organisation from first principles, to the agreement of the TDSCG. See Chapters 5, 8 and Appendix D for additional guidance.

3.17 *Tunnel Cross Connections*: Tunnel cross-connections are generally of three types:

- i. A single set of fire doors in the partition wall between two traffic bores.
- ii. A cross passage with fire doors at both ends providing a safe refuge and an escape route from one bore to the other.
- iii. Access doors to a central escape shaft or passage, leading to a safe exit.

The second and third types above require ventilation to maintain a supply of fresh air to the escape route and positive pressure or other provisions to exclude smoke from any fire within a traffic bore. Where two or more bores are linked by cross connections, the effect of opening one or more of those cross connection doors shall be considered in both normal and emergency situations. The design shall incorporate features which reduce or eliminate any hazard caused by the opening of such a cross connection.

3.18 *Vehicle Cross Overs*: Vehicle cross overs shall be provided on tunnel approaches to enable contra flow working in twin bore tunnels, or convoy working (see TA63 DMRB(8.4.5)) in single bore tunnels for maintenance etc. If there is a junction near the tunnel, care shall be taken to ensure that all traffic can use the cross overs. Care shall also be taken with sight lines through cross-overs, particularly those adjacent to widely spaced twin bores and provision made for suitable temporary or permanent signing, including any necessary speed limit signs. During normal operation, suitable means of preventing vehicles from crossing from one carriageway to the other shall be provided to avoid a safety hazard. Movable or demountable barriers, when implementing contraflow operation, shall be evaluated in terms of possible reductions in maintenance costs.

3.19 *Turning Bays*: In tunnels of over 5 km length, turning bays of sufficient size to enable a lorry to turn around shall be provided, not more than 1 km from the middle of the tunnel.

3.20 *Emergency Services Parking*: If necessary, an area close to the tunnel portals shall be provided for the parking of police and emergency services vehicles and equipment when attending a tunnel incident.

3.21 *Toll Booths*: Toll booths, if required, shall be sited at sufficient distance from the tunnel portals to allow traffic to return to free flow conditions before

entering the confines of the tunnel. This affects not only safety, but also the pollution levels in the tunnel. In general, toll booths should be sited at least 300m from a tunnel.

3.22 *Drainage Sumps*: Drainage sumps shall be sized to accept, and be equipped to contain with safety, the largest spillage that may reasonably be expected to occur within the tunnel. Unless by law restrictions are imposed and enforced, the volume to be assumed is 30m³, which approximates to the total contents of a large tanker vehicle.

Tunnel Communications and Emergency Facilities

3.23 *Communications*: Emergency roadside telephones within the tunnel allow road users to communicate directly with the tunnel or police traffic control centre. Radio rebroadcasting equipment will enable emergency services and maintenance staff operating within the tunnel to maintain communications. To warn, guide and assist road users during tunnel emergencies use of flashing signals, RDS radio broadcasting, in-car communications, klaxons and public address systems which are effective in high ambient noise conditions should be considered, as an effective means of reducing the risks of loss of life or injury.

3.24 *Traffic Controls*: The safety and pollution hazards from traffic disruption within a tunnel may be readily appreciated. Appropriate levels of equipment for measurement of traffic speed and density, traffic surveillance (eg CCTV) and control, together with a comprehensive system of signs and signals shall be developed in close cooperation with the Overseeing Organisation (which has the overall responsibility for authorising such installations on its motorways and other trunk roads). Tunnel traffic control systems shall be integrated with local networks and neighbouring traffic control systems

3.25 *Tunnel Systems - Emergencies*: Systems relating to emergency points and the response to tunnel emergencies shall be linked with the tunnel plant monitoring and control centre.

3.26 *Fire Alarm, Extinguishers, Smoke Control*: Facilities for raising an alarm, either by manual or automatic means, and responding to a fire shall be provided to safeguard all areas of the tunnel including the tunnel services building. Extinguishing equipment, and where relevant, facilities for controlling smoke by means of ventilation override shall be in accordance with the relevant chapters of this document.

3.27 *Emergency Lighting and Power:* In the event of failure of the normal power supply an alternative source of power will maintain power to operational and safety systems and permit use of the tunnel to continue. See Chapter 11.

instances be subject to failure and short service life. It is therefore essential that no more equipment is installed than is absolutely necessary to keep safety at an acceptable level, while maintaining the confidence of tunnel users. Suitable guidance may be found in the Highways Agency Value for Money Manual.

Value Engineering

3.28 It shall be recognised that safety equipment is expensive to install and maintain, and can in some

SAFETY AND FIRE PREVENTION EQUIPMENT		TUNNEL CATEGORY				
		AA	A	B	C	D
Communication and Alarm Equipment	Emergency Telephones	●	●	●	●	*
	Radio Rebroadcasting System	●	○	○	○	
	Traffic Loops	●	○	○	○	○
	CCTV	●	○	○	○	○
Fire Extinguishing Equipment	Hand Held Fire Extinguishers	●	●	●	○	
	Pressurised Fire Hydrants	●	●	●	●	○
	Fire Hose Reels	●	○	○	○	
Signs and Rescue Equipment	Emergency Exit Signs	●	●	●	○	○
	Lane Control and Tunnel Closure Signs/Signals	●	●	●	●	○
Other Provisions and Equipment	Emergency Stopping Lane	●	●	●		
	Emergency Walkway	●	●	●	●	○
	Escape Doors	●	○	○		
	Turning Bays	○				
	Ventilation for Smoke Control	●	●	●	○	○

- Normal provision
- Requirements to be determined by TDSCG
- * Provision determined by local requirements

See Figure 3.1 for tunnel category.

Table 3.1 Basic Safety Provisions For Each Tunnel Category

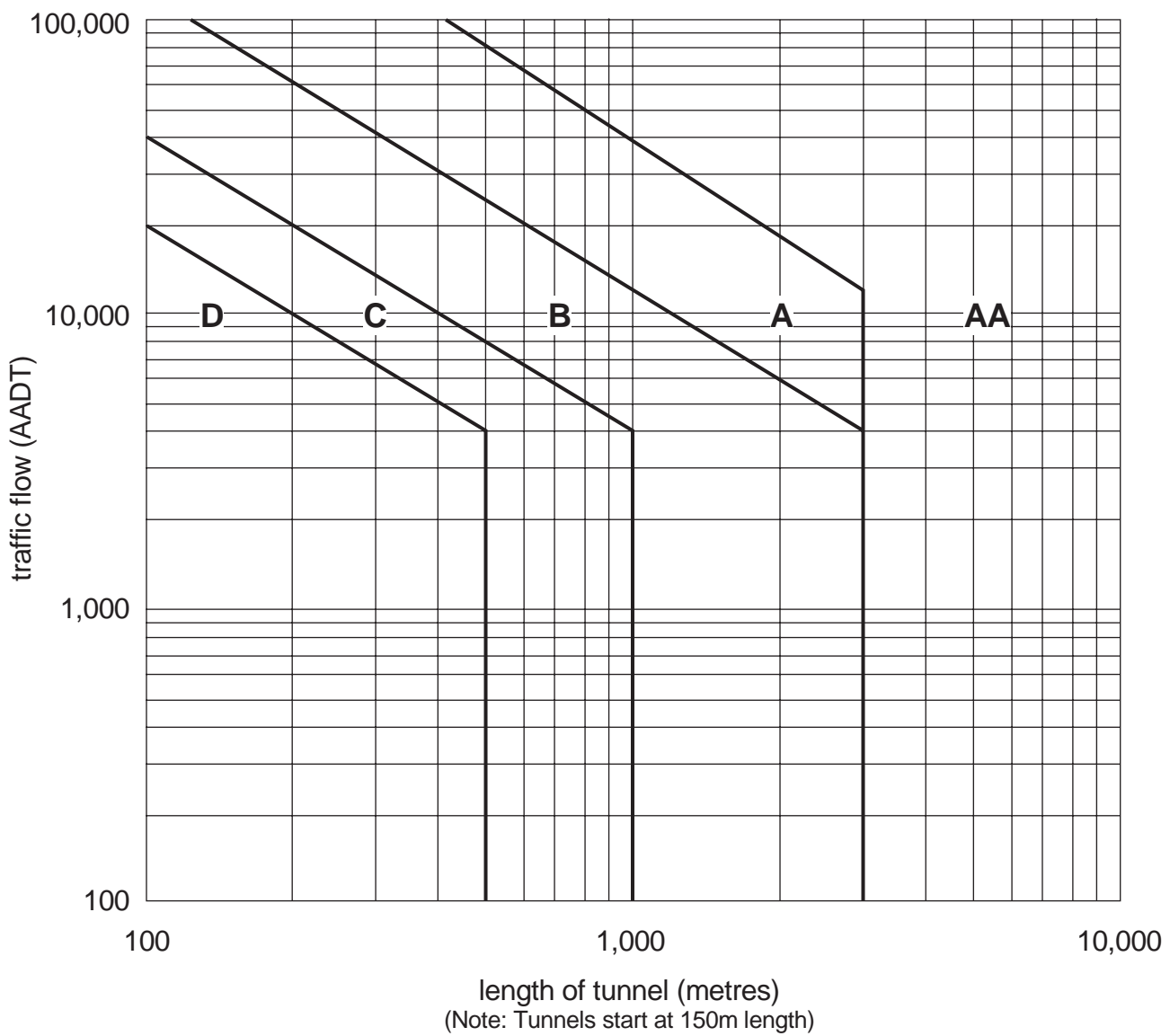

Figure 3.1

Determination of Tunnel Category

4. GEOMETRIC DESIGN

General

4.1 This Chapter describes the requirements for the geometric design of carriageways within road tunnels and the provisions to be made for traffic space in relation to the structure and form of tunnel that has been chosen following the engineering appraisal of scheme options. The requirements provide the adjustments that are to be made to the Standards used for the design of carriageways on open roads. These adjustments make allowances for the special demands and conditions of approaching and driving through tunnels.

4.2 Geometric design and traffic space requirements are presented from the standpoint of providing safe passage, under free flow conditions, for the type of traffic that is permitted to use the tunnel. Basic layout and tunnel geometry, however, shall also be related to other aspects concerning the design and operation of a tunnel. This may affect tunnel geometry or require additional space beyond that needed to enclose specified carriageway widths and traffic clearances eg requirements for:

- i. Ventilation (length and gradients)
- ii. Traffic movements (maintenance, emergencies)
- iii. Portals (provision for parking/turning emergency vehicles)
- iv. Operational Safety (verge widths, lay-bys and long tunnels)
- v. Traffic escort (marshalling facilities in portal areas)
- vi. Adjacent road network (disruption or queues due to tunnel closures, etc).

For further information, reference should be made to relevant sections of this document.

4.3 The geometric planning and design of tunnels is an iterative process. Initial plans shall be based on the design criteria and hourly traffic flows for comparable sections and classes of open road. Consideration shall then be given to the physical characteristics of the tunnel profile and cross section, the design of the approach roads, and the proximity of the tunnel portals to any surface junctions. Account shall be taken of high and

low traffic demands, the composition and speed of the traffic flow, construction costs, and the economic and safety benefits that ensue. Drivers shall be aware of their approaching a tunnel and of any need to adjust their driving style accordingly.

Junctions in Tunnels

4.4 The safe provision of junctions within, and in close proximity to, tunnels is made difficult by limited sight lines, limited space for advance warning and direction signs and the high constructional cost of producing variations to a tunnel cross-section. The increased accident risk at junctions is undesirable in a tunnel because of the restricted access for the attendance of the emergency services. The provision of junctions in tunnels should be avoided and alternatives determined.

Geometrical Standards

4.5 Geometrical design standards are influenced by the special features of tunnels which distinguish them from open road conditions. Departures from Standards that would normally be adopted for comparable sections of open road could be considered by the Technical Approval Authority of the Overseeing Organisation, bearing in mind that tunnels are special sections of road requiring high investment for their construction, operation and maintenance.

4.6 The nature and extent of any modifications to the criteria that are used for open roads, particularly Standards TD9 (DMRB 6.1.1), TD20 (DMRB 5.1) and the Traffic Appraisal Manual (DMRB 12.1), will vary according to the circumstances at each tunnel and a detailed consideration of the following:

- i. Traffic composition and design flows
- ii. Design speed
- iii. Sight distances and the relations between alternative tunnel cross-sections and minimum horizontal radii
- iv. Scope for tunnel widening at curves
- v. Basis of tunnel operation (one way, two way, contra flow)

- vi. Tunnel cross section
- vii. Approach road geometry and traffic measurements (lane merge, diverge, climbing lane, proximity of junctions)
- viii. Any other aspects peculiar to a particular tunnel.

Tunnel Traffic

4.7 Confirmation of carriageway width and number of lanes shall be based on the maximum hourly design flow rates set out in Table 4.1 and correction factors of Table 4.2. Cut and cover tunnels shall be designed for the flow rates set out in TD20 (DMRB 5.1).

4.8 The figures in Table 4.1 shall be corrected for the tunnel gradients and percentage of HGVs. Correction factors are set out in Table 4.2 and apply to bored/driven tunnels and immersed tube tunnels, but not to cut and cover tunnels. The gradient shall be based on the average of a 0.5 km section.

Design Speed, Stopping Sight Distances (SSD) and Overtaking

4.9 Additional definitions are required for road tunnels:

- i. *Approach Zone*: The length of approach road from the portal equal to 1.5 times the open road SSD.
- ii. *Threshold Zone*: The length of tunnel, measured from the portal, which an obstruction shall be clearly visible, so that a driver approaching a tunnel, having passed the last point at which he or she could stop before the portal, will be able to avoid the obstruction.

4.10 The tunnel design speed shall be the same as the approach road design speed.

4.11 Table 4.3 shows the recommended relationship between the speed limit, the design speed and stopping sight distances (SSD) and Table 4.4 between the design speed and the horizontal curvature, based upon TD9 (DMRB 6.1.1) alignment standards.

4.12 Stopping sight distance (SSD) is determined from the design speed, the driver's reaction time and the average deceleration rate to stop. The desirable SSD is based on a 2 second reaction time and 0.25g deceleration and is shown in Table 4.3.

4.13 A reduction of one design speed step (10mph) may be used for determining SSD on approach and threshold zones where drivers are alerted by signing for a tunnel ahead. Inside the tunnel, away from the portals, the road surface can be expected to retain a higher skid resistance and a further one design speed step Relaxation may be applied. The resultant minimum SSDs are given in Table 4.3.

4.14 Such Relaxations shall only be used over the adoption of desirable standards to TD9 (DMRB 6.1.1) where they are warranted by benefits, and shall not be used in combinations with any other layout Relaxations or Departures.

4.15 SSD and Full Overtaking Sight Distance (FOSD) shall be verified in both vertical and horizontal planes, at the centre of the inside lane on curves, as described in TD9 (DMRB 6.1.1).

4.16 Overtaking in a road tunnel, involving access to the lanes open to traffic travelling in the opposite direction shall not be permitted.

Horizontal Curvature

4.17 On tight curves on open roads, the required SSD can be achieved by widening verges etc to provide the necessary sight lines. As this is impractical in most tunnels, the degree of horizontal curvature attainable will be restricted by the need to achieve the minimum SSD.

4.18 For many situations, TD9 (DMRB 6.1.1) permits relaxations below the desirable minimum horizontal radius of between 2 and 4 design speed steps, depending on the type of road. Table 4.4 compares these minimum horizontal radii with those required to achieve the minimum SSD for a tunnel of typical cross-section. It can be seen that in most instances it is the SSD requirement which limits the horizontal curvature, especially for all purpose roads where more relaxation steps are permitted.

4.19 It is important to check the SSD for each horizontal curve, as it depends on the length of the curve as well as its radius and the tunnel cross-section.

Vertical Alignment

4.20 *Crest Curves*: At crests, visibility may be obstructed by the intervening road. TD9 (DMRB 6.1.1) gives details of crest curve and visibility requirements.

4.21 *Sag Curves*: To accommodate long full height vehicles, TD27 (DMRB 6.1.2) requires additional headroom clearance for sag radii of 6000m, or less. SSD and FOSD shall be checked for a driver's eye height of 2.0 m. If the minimum values are not achieved either the tunnel headroom should be increased (which will not normally be economical, particularly in a bored tunnel), or, if practical, the speed limit reduced. Visibility on sag curves will not normally be a problem with full height tunnels.

4.22 *Gradients*: For tunnels the penalties of steep gradients are more severe than on open roads and will include higher ventilation costs, due to increased vehicle emissions. Also traffic speeds may be reduced unacceptably with large proportions of HGVs. Trunk road tunnels with gradients exceeding 6% are unlikely to be practical. A climbing lane is not normally a practical provision within a tunnel. In a steeply graded bi-directional tunnel, for example, a climbing lane might be provided by a 3 lane carriageway, two lanes up and one down. Where adequate alternative routes can be provided, it may be advantageous to prohibit heavy vehicles from steeply graded tunnels. Any proposed departure in a tunnel from the open road desirable maximum gradient shall be subject to a cost-benefit study.

4.23 *Superelevation*: To provide comfortable levels of lateral acceleration, it is desirable to provide superelevation for certain levels of horizontal curvature. The standards for superelevation are set out in TD9 (DMRB 6.1.1). However, the provision of superelevation may have an adverse effect on the tunnel cross section and on the provision of service ducts under the road. The full recommended levels of superelevation provide only small compensation for lateral acceleration and, where necessary, may be relaxed to the minimum crossfall needed for occasional drainage requirements.

4.24 *Crossfalls*: On the open road, where the superelevation is not greater, a crossfall of 2.5% (1 in 40) is used to provide stormwater drainage of the road surface. For tunnels, the need to drain the road surface arises from routine wall washing, flushing away accidental spillage and any seepage. It is recommended that the normal cross-fall of 2.5% is provided throughout the tunnel.

Clearances for Traffic

4.25 All equipment in a road tunnel shall be placed outside of the equipment gauge. The equipment gauge for a road tunnel is determined by the traffic gauge (the theoretical clearance envelope required for

vehicular traffic ie maintained headroom etc) plus, for vertical clearance, an additional allowance of 250mm. This additional clearance gives some protection to "soft" equipment, such as luminaires, from high vehicles carrying compressible loads that have passed under the portal soffit, loose ropes, flapping tarpaulins etc. Clearances shall be carefully related to carriageway and side verge widths and to the structure gauge ie the minimum "as-built" structural profile that the tunnel must achieve. [Dimensional tolerances of bored, cut and cover and immersed tube tunnels are strongly influenced by the construction process].

4.26 Additional clearances to avoid damage to electrical, mechanical and communications operational equipment shall be provided as follows:

- i. **600mm horizontally from edge of kerb**
- ii. **Other dimensions as given in Figures 4.1 and 4.2.**

Width

4.27 Traffic lane widths in tunnels shall be in accordance with TD27 (DMRB 6.1.2). These clauses do not apply to limited facility tunnels, see Chapter 1.

4.28 The need for provision of carriageway hard strips within a road tunnel shall be subject to a cost benefit study undertaken by the Design Organisation and considered for approval by the Technical Approval Authority of the Overseeing Organisation.

Height and Asphalt Types

4.29 The maintained headroom, in Figures 4.1 and 4.2, shall be based on the same requirements of TD27 (DMRB 6.1.2): Chapter 5, as for over-bridges on open roads, and may need to be compensated for on sag curves. Further guidance is contained in BD65 (DMRB 2.2.5): Design Criteria For Collision Protection Beams. The maintained headroom does not include any allowance for pavement overlays for which appropriate (and minimal) adjustments to headroom shall be made. The Overseeing Organisation will confirm whether the tunnel is to form part of a High Load Route. This clause does not apply to limited facility tunnels, see Chapter 1.

4.30 The life of asphalts within tunnels can be longer than on the more exposed open roads. The planned use of micro-surfacing (coarse graded slurry seals) or thin wearing course surfacing should be considered to reduce

whole life costs of surfacings and the disruption, dust and fumes of planing out and relaying operations within tunnels. Porous asphalts are unsuitable as they may retain flammable or toxic spillages arising from an incident.

Side Verges

4.31 Pedestrians are prohibited from using trunk road tunnels. However, verges need to be provided as walkways for road users during emergencies and for tunnel maintenance and operating personnel. Verges provide a convenient location for drains, fire mains, fireproof cable ducts etc, free from the regular pounding of heavy vehicles.

4.32 Verge widths will often be determined by the extent of provision for services beneath or the need for driver visibility. A 250mm width is needed to prevent vehicles from contacting the sides of a tunnel. The minimum verge width shall be 1.0m. The maintained headroom need be provided over only the first 0.6m of the verge as shown in Figures 4.1, 4.2 and Table 4.5. A kerb height of 0 to 75mm facilitates the opening of car doors, on the nearside, so that occupants are not forced to exit into the offside fast moving traffic. A low kerb is easier to mount, particularly by those who are disabled or injured. It is also easy for a vehicle to mount to allow stopping out of the traffic stream, especially if a half battered profile is used. The verge is to be designed to take the weight of a fully laden HGV. For rectangular cross section tunnels, if drainage aspects for all circumstances permit, then the need for any raised kerb should be considered. Drainage shall not pond against the tunnel wall structure to cause structural corrosion. For tunnels of a circular cross-section, the provision of a low level kerb is necessary to guide vehicles away from areas of low headroom. Particularly for multi-lane circular tunnels, care is needed to avoid unnecessarily increasing the cross section and consequent construction costs.

4.33 In the exceptional circumstance of a need of provision for pedestrian use of a road tunnel, then consideration should be given to a separate bore for the pedestrians. If this is not possible, a guarded walkway at least 1000mm wide shall be raised 500mm or more above the road surface to protect the pedestrians from traffic. A partition from the main tunnel with separate ventilation for the walkway, should also be considered. When a raised walkway is used, it is desirable to maintain the provision of a low-level verge for emergency use by vehicle occupants and to improve sight-lines on bends.

Safety Fences

4.34 Provided that the lower 1.2m of tunnel side walls are smooth and continuous (to avoid “snagging” during vehicle impact) and are structurally resistant to impact from vehicles, then the walls shall be considered to provide the same function as vertical concrete safety barriers, as used on the open road, and the provision of additional safety fencing is neither desirable nor necessary. At emergency cross passage doorways and open recesses, the exposed, upstream vertical lower edge of the doorway or recess shall be chamfered horizontally, over a height of 1.2m, at an angle of 1 in 12 to the traffic direction. The horizontal depth of chamfer, at the leading edge, shall be 30mm. On balance, it is also not considered desirable to provide pedestrian safety barriers opposite the exits from emergency cross passages. Such barriers may hinder the vital work of the rescue services during an emergency within a congested tunnel. Cross passage doors are provided with glazing to ensure awareness of oncoming traffic within the bore exited to, as well as establishing the presence of any smoke from a fire.

Tunnel Flow/Type		Cut and Cover	Bored Tunnels	Immersed Tubes
Uni-directional	v/hr/lane	TD20 (DMRB 5.1)	2000	2000
Bi-directional	v/hr/lane	TD20 (DMRB 5.1)	1800	1800

Note: Over or underestimation of traffic capacities can lead to severe economic penalties especially for major tunnels. Special scheme specific studies may be beneficial. Refer to PIARC Technical Committee on Road Tunnels report XVII World Roads Congress, Sydney 1983.

Table 4.1 Maximum Hourly Design Flows

% HGVs	Gradient	
	< 2%	> 2% < 4%
5	-	-15
10	-5	-20
15	-10	-25
20	-15	-30

Table 4.2 Percentage Correction Factors

Speed Limit	mile/h	70	60	50	40	30
Design Speed	km/h	120	100	85	70	60
Desirable SSD	m	295	215	160	120	90
One Step Relaxation	m	215	160	120	90	70
Two step Relaxation	m	160	120	90	70	50

Table 4.3 Design Speed, Stopping Site Distances

Design Speed	km/h	120	100	85	70	60
	Super-elevation *	Radius (m)				
Desirable minimum for open road from TD9 (DMRB 6.1.1): Table 3	5%	1020	720	510	360	255
Typical SSD Determined Minimum Horizontal Radii for 2 or 3 lane one-way tunnels with 3.65m lane width, 1.0m hard strips and 1.0m verges on both sides						
Desirable Minimum	5%	2850	1510	840	470	265
One Step Relaxation	7%	1510	840	470	265	160
Two Step Relaxation	7%	840	470	265	160	80

* Superelevation in tunnels may be relaxed as stated in text.

Table 4.4 Horizontal Curvature in Tunnels to Provide SSD Standards

Dimension	Description	Box Profile	Arch Profile
A	Walkway headroom	2300mm	2300mm
B	Width of verge with full headroom	600mm	600mm
C	Width of verge	1000mm	1000mm

Table 4.5 Minimum Dimensions (See Figures 4.1 and 4.2)

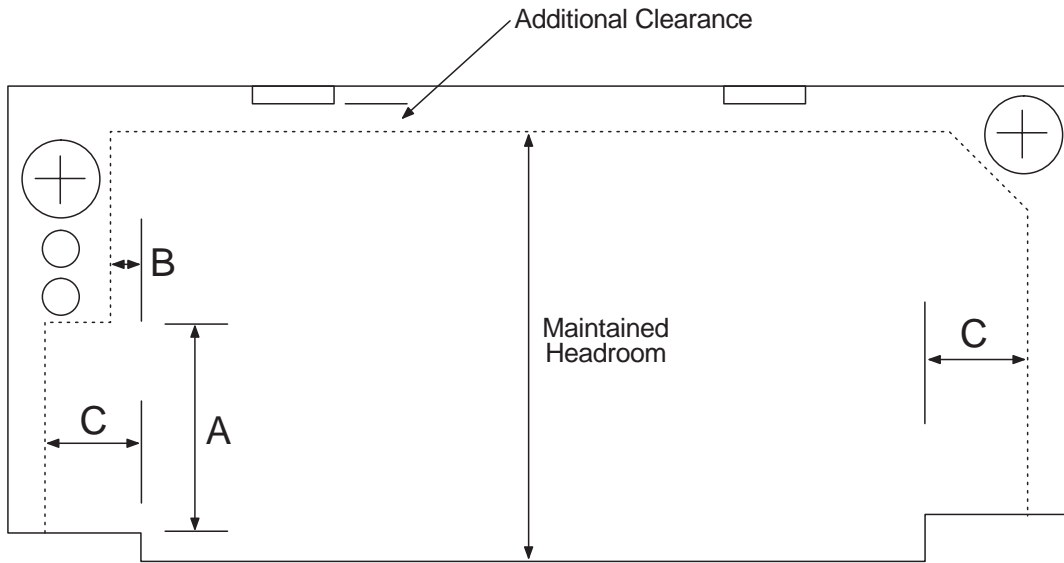

Figure 4.1 Example Box Profile

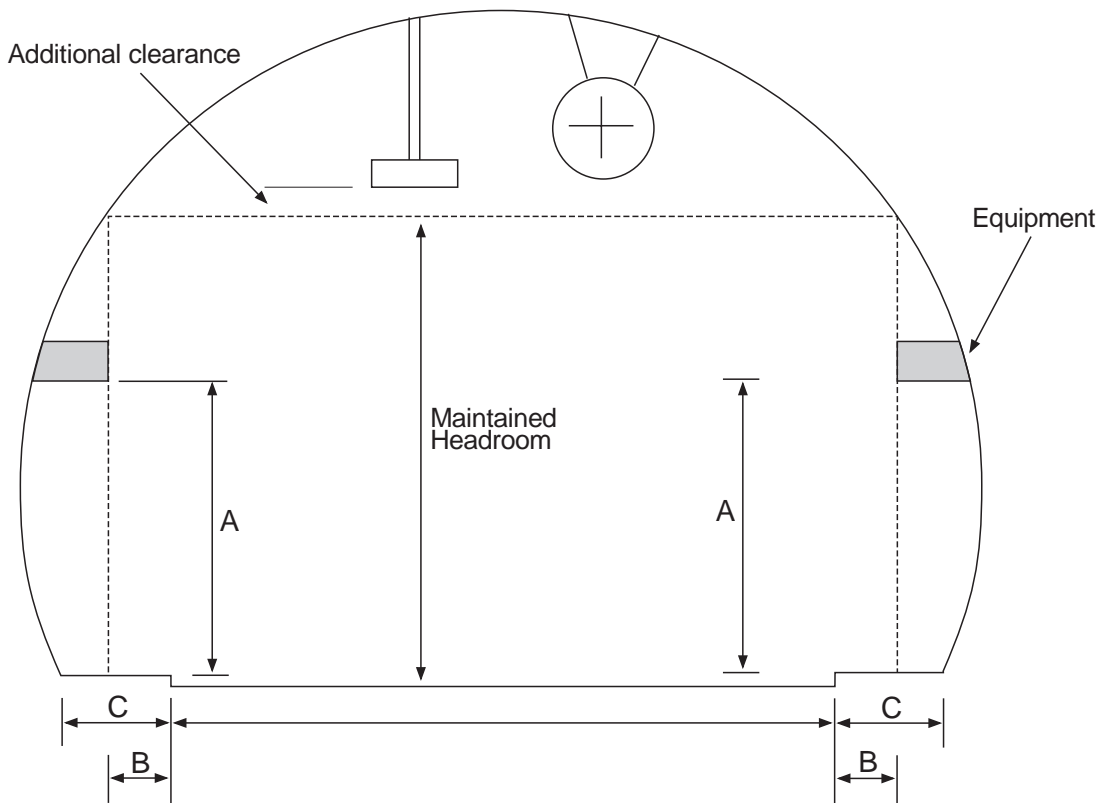

Figure 4.2 Example Arch Profile

Graphic Services 980983.DSF

5. VENTILATION

General

5.1 This Chapter provides information and criteria for the evaluation and basic design of tunnel ventilation systems. Ventilation systems shall be designed to supply sufficient fresh air to all parts of the tunnel; maintain vehicle exhaust pollutants within prescribed limits; provide a hazard free environment for tunnel users, the local community and any amenities likely to be affected by the discharge of fumes from the tunnel. Forced tunnel ventilation is also normally required to control smoke and heat in the event of a fire in a tunnel and direct it away from tunnel users, whilst they escape, and in providing cool, fresh air for fire fighters tackling the blaze. For some tunnels, natural ventilation will be sufficient to maintain the required air quality but forced ventilation will be needed if fire smoke control is required.

5.2 Thresholds for the dilution and control of toxic emissions and smoke from vehicles are provided, together with selection criteria for the choice of appropriate systems of tunnel ventilation. Requirements for the day to day operation of mechanical systems of ventilation are described, including the response they shall provide in the event of a fire.

5.3 A forced ventilation system is an important facility for restoring safe conditions in the event of a tunnel fire. The relationship between the length of the tunnel; distance to emergency exits; highway gradients; the traffic (one way, two way, volume and composition with respect to percentage of HGVs, transport of dangerous goods (see Chapter 2)); safety installations and the planned response to emergencies are all relevant factors in deciding the most appropriate ventilation regime to deal with a fire situation.

5.4 The actual number of vehicles in a tunnel at any one moment will depend on the average vehicle speed and the traffic density. Typically, as traffic slows, the total number of vehicles within a tunnel will increase. The vehicle induced air movement referred to as 'the piston effect', is significantly reduced at lower traffic speeds. The larger number of vehicles will increase the total drag resistance to air movements. Many tunnels are likely to be self ventilating for long periods when traffic is flowing freely, but can lose almost all of their self ventilating capacity when traffic is congested, at rush

hours, say. In addition, fuel combustion is less efficient in congested conditions, increasing pollution rates.

5.5 An assessment of the needs of a tunnel ventilation system shall be based on providing tunnel users with adequate protection from the toxic effects of vehicle emissions; adequate visibility from the accumulation of smoke emitted by diesel vehicles; the need to control the disposal of tunnel pollution to the atmosphere.

5.6 As part of the analysis of factors that determine fresh air requirements for the dilution of vehicle pollutants, consideration shall be given to establishing the tunnel ventilation capacity available to control the direction of smoke and assist evacuation and fire fighting procedures, as described in Chapter 8.

5.7 The form of ventilation applied to a specific tunnel will depend on many factors including:

- i. Location of the tunnel with particular regard to the potential impact on the local environment
- ii. Design year in respect of forecast traffic levels and its composition
- iii. Tunnel geometry, altitude and local topography
- iv. Fire safety considerations

5.8 Tunnel ventilation design standards are constantly evolving through international initiatives. The prime influences on this process are:

- i. The steadily tightening of vehicle emission laws
- ii. Improved understanding of fire behaviour
- iii. Developments in modelling techniques and analytical tools
- iv. Increasing concern for health and safety and the environment.

5.9 The following international bodies are prominent in the advancement of ventilation design standards and methods and many organisations arrange conferences and symposiums to advance the designer's awareness:

- i. World Roads Association PIARC Permanent International Association of Road Congresses

- ii. BHRG British Hydraulic Research Group
- iii. WTC World Tunnelling Congress
- iv. WHO World Health Organisation.

5.10 The following bodies shall be consulted in confirming the ventilation system/s to be adopted for a specific tunnel:

- i. Local Planning Authority
- ii. TDSCG Tunnel Design and Safety Consultation Group
- iii. Proposed Tunnel Operating Authority
- iv. Traffic Control Authority for the area.

Systems of Tunnel Ventilation

5.11 There are several types of ventilation system, natural and mechanical, that have been proven effective in use. Many factors have an influence on the choice of a mechanical ventilation system and should be taken due account of in accordance with their relative importance to a particular scheme. The end result for a mechanical ventilation system shall be an aerodynamically sound system, one that provides satisfactory environmental conditions inside the tunnel and adjacent to it, controls smoke in the event of fire, has acceptable capital and running costs, and satisfies the operator in terms of control, maintenance and cleansing.

5.12 The parameters of a suitable and economical ventilation system for a particular tunnel layout will be determined by:

- i. The purpose, length, gradient, cross-section and general configuration of the tunnel.
- ii. Its location and general impact on the local environment. Environmental considerations at portals and shaft outlets (if provided).
- iii. Predicted traffic conditions, taking into account number of lanes, whether traffic flow is one way, two way, or tidal flow, design flows, traffic speed and its composition, dangerous goods traffic.
- iv. The nature and frequency of traffic congestion in the tunnel including any requirements for contra-flow working during maintenance periods.
- v. The influence of road layouts either side of the tunnel.

- vi. Vehicle emission levels.
- vii. Fires and their likely severity
- viii. Capital investment and running costs, maintainability.

5.13 In many short one-way tunnels, of up to 300m length, the 'piston effect' of vehicle induced air flow will provide satisfactory natural ventilation for normal environmental needs, also emergency evacuation routes to places of refuge can be made acceptably short (100m preferred limit, 150m maximum limit). For tunnels of between 300m to 400m length, mechanical ventilation plant will need to be considered with respect to fire smoke control, for example, where traffic is relatively light and/or gradients are not steep, the length of tunnel where mechanical ventilation plant is unlikely to be required may be increased to 400m. Mechanical ventilation is required for all longer (400m and above) tunnels and for (200m and above) tunnels on steep gradients or those subject to frequent congestion, either due to high usage or external traffic conditions, where it is self evident to be unacceptable to close the tunnel to traffic for short periods to clear pollution levels naturally.

Natural Ventilation

5.14 The natural longitudinal draught through all road tunnels is made up from 'the piston effect' of moving vehicles, the wind forces and to a lesser extent pressure differences due to other meteorological conditions. For air movement to occur, such forces need to overcome the drag resistance of the tunnel interior surface and the vehicles within the tunnel. Natural ventilation can create considerable pressure and air velocities within a tunnel which must also be taken into account in the design of mechanical ventilation systems.

5.15 With a steady natural air flow through a one way tunnel, in the direction of traffic flow, the exhaust emission concentration increases from the entrance (ambient air or background value) up to a maximum value near the exit portal. If the combined resultant force on the tunnel air changes direction, an oscillating movement of the air can result, causing the maximum exhaust concentration to be nearer the centre of the tunnel. Because there will be no certain control of air direction or velocity, natural ventilation cannot be fully relied upon to prevent the build up of unhealthy fumes, obscuration or contamination occurring within a tunnel during still, adverse wind or slow moving traffic conditions. For tunnels without mechanical ventilation, arrangements will need to be planned for that, under

adverse pollution conditions, prevent further vehicles entering the tunnel and communicate to drivers of stationary vehicles, already in the tunnel, to switch off engines. Natural ventilation will not provide control of smoke etc in the event of a fire.

Longitudinal Mechanical Ventilation

5.16 Longitudinal ventilation is the simplest form of tunnel ventilation and because of lower capital and running cost benefits, is often the first choice. See Figure 5.1. There are three basic methods of providing longitudinal mechanical ventilation:

- i. Jet fans mounted within the tunnel at a limited number of points to create a longitudinal flow of air along the length of the tunnel. Air enters at one portal and is accelerated to discharge at the other.
- ii. Injectors, directing jets of fresh air into the tunnel, which induce a secondary flow through the entry portal and enhance the longitudinal flow
- iii. Push-pull arrangements of axial type/jet fans.

5.17 Longer tunnels can be split into two or more ventilation sections, with discharge and inlet shafts forming the junction of each section.

5.18 The longitudinal system is widely used for short to medium length tunnels to enhance natural longitudinal ventilation. It may also be used for longer tunnels with the introduction of intermediate ventilation shafts, or air cleaning provisions. Friction losses increase with the length, cross section perimeter and roughness of the tunnel interior surface. Ventilation energy losses at portal entrances and exits may be reduced by a flaring of the structural form.

5.19 With longitudinal flow, the degree of pollution rises progressively along the length of the tunnel to a maximum at the point of discharge. The polluted air is normally discharged directly through the tunnel portal, but this may be unacceptable in certain urban conditions in which case a discharge shaft and extract fan could be necessary.

5.20 With two way traffic, 'the piston effect' of natural ventilation is largely lost, pollution concentrations are more evenly distributed along the length of the tunnel. Exhaust shafts may need to be located at intermediate points in longer tunnels. In its simplest form, where a single shaft is located centrally, the system shall create inward air flows from each portal to this central point.

5.21 For shorter tunnels, with two way traffic, longitudinal ventilation could be from portal to portal but has an adverse effect on long term running costs to consider. Smoke control and emergency service response in the event of a fire will need careful consideration.

5.22 Calculations of jet fan capacity shall take into account that air velocities shall be sufficient for control of fire smoke. The fans shall be capable of reverse operation so that with eg contra flow traffic, smoke can be moved to the nearest exit.

5.23 Longitudinal ventilation systems, designed for one way tunnels, are usually unsuitable for contra flow operations in tunnels for the following reasons:

- i. With one way operation, the system benefits from the traffic induced 'piston effect' and, under certain traffic or weather conditions, the tunnel becomes self-ventilating. With contra flow, not only is there a tendency to neutralise the 'piston' and wind effects, but turbulence occurs giving rise to pockets of polluted air that remain undetected by the ventilation control sensors, placed towards the normal exit of the tunnel. Tunnel lighting levels, if designed for one way operation, will also be incorrect.
- ii. In the event of a fire, the ventilation system would initially respond automatically to the reduced visibility (due to fire smoke) by ventilating in one direction to control air quality. This will lead to hot smoke being passed over the opposing queue of traffic. The worst scenario is with a fire located closest to the supply (normal entrance) portal or shaft, where the smoke would be passed over the longest queue of traffic. Reversing the airflow of the fans would take time (notionally 20 minutes) leading to smoke logging of the whole tunnel and the risk of mass asphyxiation.

5.24 Nevertheless, contra flow operation may be used sparingly in order to facilitate maintenance operations in one bore of a twin bore tunnel, say. Such operation requires close supervision and shall be limited to periods of light tunnel traffic (eg at night time closures).

5.25 In exceptional cases, longer two way tunnels may be considered for longitudinal ventilation if traffic flows are low and risk analysis demonstrates that the probability of a fire is remote. This may be achieved, for instance, by enforced restriction of the use of the tunnel by vehicles carrying hazardous loads or by implementing suitable traffic control measures to limit the number of vehicles in the tunnel at any one time.

5.26 Generally, longitudinal ventilation is the most economical type of system since it places the smallest operating burden on the fans and does not require separate air duct provision. Power consumption can become significant where longitudinal ventilation is provided by jet fans which are needed to operate more or less continuously. With one-way traffic flow, longitudinal ventilation with jet fans is the normal solution.

5.27 The tunnel profile will influence the position of jet fans within the equipment gauge. Driven tunnels with circular or inverted 'U' profiles allow the fans to be mounted within the arched ceiling. 'Cut and cover' rectangular profile tunnels may require extra construction height to accommodate the fans or, where constraints preclude this, fans can be placed in wall or ceiling recesses (niches) but with some loss of ventilation efficiency, particularly at corner locations. Fans shall be positioned at some distance from signage and other fixed equipment. Reversible fans are able to overcome adverse wind forces and directions by reversing to the direction of the wind. Fans are sequenced in running to even out wear. Allowance must be made in fires that fans local to the fire may burn out, along with their supply cables.

5.28 The strategy is to make as much use of natural longitudinal ventilation as possible and supplement this for short periods by jet fans. Relative to semi transverse or transverse ventilation this means reduced operation and construction costs.

5.29 With normally free moving traffic, longitudinal ventilation with jet fans, moving air from portal to portal, is feasible for tunnel lengths up to 5km, depending on the design criteria for traffic density and emissions. Reversible jet fans should normally operate in the same direction as the main traffic flow. The maximum allowable longitudinal air velocity for safety, from forced ventilation, is 10 m/s.

Fully Transverse Ventilation

5.30 Fully transverse ventilation is the most comprehensive form of mechanical ventilation but because of its high capital and operational costs, is seldom adopted for new tunnels.

5.31 Fully transverse ventilation works independently of any natural longitudinal flow. It depends on "vertical" flow, across the tunnel cross section, from a supply duct to an extract duct, each with separate fan systems. Supply and extract connections to the road space are located along the whole length of the tunnel.

5.32 Air movements within the traffic space impose no limitations on the suitable length of tunnel. There is not a progressive build-up of pollution, as is the case of longitudinal flow, since pollutants are extracted almost at source. Using controlled dampers, maximum allowable air velocities do not impose limits on the duct lengths used. Localised requirements, for example at increased pollution sections along gradients, can be met by increasing supply and exhaust rates at that section. The pattern of ventilation is not affected by the direction of traffic flow.

5.33 Transverse ventilation systems may be classified as upward, lateral, or downwards (extracting) according to the positions of the supply and exhaust ducts. The upward air flow ie. inlet air at low level with exhaust at high level is the most effective layout both for normal pollution control and for smoke control in an emergency. See Fig. 5.2. In the event of a fire, smoke is extracted directly, aided by its buoyancy, and thus the longitudinal spread of smoke and hot gases becomes effectively limited.

5.34 Downwards extraction is not suited to smoke control as it would interfere with stratification (smoke etc in the upper layer with cooler fresh air below) and draw smoke down to the evacuees.

5.35 Lateral extraction is a compromise between upward and downward extraction and may be acceptable for smoke control if extraction is effectively achieved in the upper reaches of the tunnel bore.

5.36 Fully transverse ventilation is, in theory, the ideal system for long tunnels for two way traffic and for smoke control and removal. A tunnel of circular section provides space for a transverse ventilation system below the road level and above the traffic gauge. Capital costs are higher, compared with semi transverse systems, because separate ducts must be provided for supply and exhaust. As a rule of thumb, operational energy costs increase in proportion to the fourth power of the duct length, assuming a consistent cross section throughout. Soot accumulations in the exhaust duct making cleaning necessary.

Semi Transverse Ventilation

5.37 Semi transverse ventilation has frequently been used in UK tunnels at river crossings. The flow is more complex than for fully transverse ventilation but it is able to cope with contra flow traffic more readily than longitudinal ventilation. See Fig. 5.3.

5.38 A semi transverse system typically comprises a supply duct along the tunnel whilst the whole traffic space acts as the exhaust duct, discharging either at a portal or through one or more extract shafts.

5.39 The distribution of exhaust pollutants is reasonably even throughout the tunnel, provided the fresh air supply along the tunnel is proportional to the exhaust gas produced at each location. This is achieved by baffle plates which can adjust, as necessary, the apertures of the fresh air inlets into the road space. A semi transverse system is not suitable for a reverse pattern of longitudinal supply with transverse exhaust into a duct, as large quantities of air exhausted near the point of supply will be almost unpolluted while the lesser quantities of air exhausted at the point of nil fresh air flow, towards the upstream traffic end, will lead to localised heavy concentrations of exhaust fumes.

5.40 If there is a fire in the tunnel, the fresh air supply duct shall not be turned into an exhaust duct. This would require time for the supply fans to be reversed, to draw smoke out of the traffic space and lead to smoke convection destratification problems. Little smoke would be extracted for a fire mid way between supply shafts. Care would also need to be taken to avoid damaging equipment or parts of the structure within the ventilation ducts.

5.41 Semi-transverse systems are a compromise. They are effective for one way traffic and may tolerate a limited amount of two way traffic. They can accommodate changes in the section of a tunnel eg. circular bored central region and rectangular cut and cover portal and exit sections. By the provision of intermediate ventilation shafts, ventilation beyond the lengths that are normally satisfactory for purely longitudinal ventilation are possible. The main disadvantage is the low longitudinal air velocity, particularly at the centre of the tunnel length, and care must be taken to ensure that the velocity does not fall below the requirements for efficient smoke movement in the event of fire. The mid-point null effect can be offset by boosting fresh air supply to the road-space at the null location. Care must also be taken to eliminate local stagnant areas of air and build up of pollutant concentrations on uphill gradients.

Hybrid (Combination) Ventilation Systems

5.42 Various combinations of the three basic systems (natural, transverse and semi transverse) are possible. Such arrangements have been designed to suit particular conditions. For example, a long tunnel may require a central section with transverse or semi-transverse

ventilation to provide fresh air input to an otherwise longitudinal ventilation system.

5.43 For several subaqueous tunnels (of circular section) a ventilation station, on land at the quarter point on each side of the crossing, supplies fresh air along the mid section of the tunnel through the space under the roadway. Such air is fed into the traffic space by regulated apertures at kerb level. At mid-river there is minimal longitudinal flow and from that point back to the exhaust shafts on each side the air velocity in the traffic space increases progressively. The end sections of the tunnel have longitudinal ventilation assisted by jet fans.

5.44 Maximum acceptable air velocities both in the ducts and in the traffic space impose limitations on the length of tunnel able to be ventilated from each station.

5.45 By using one set of exhaust fans only ie exhausting at the outlet portal and inducing fresh air at the tunnel inlet portal, it is possible to generate longitudinal flows of varying velocity over sections of a tunnel.

Air Cleaning Devices

5.46 In the unusual situation where there is a requirement for a long tunnel used by a high proportion of diesel engined vehicles there may be a particular problem of obscuration of visibility from engine fumes. There is not expected to be a problem in controlling the levels of carbon monoxide and oxides of nitrogen within required limits.

5.47 Excessive obscuration by diesel smoke and dust has not so far been a problem in the UK but it has had to be faced in the longer tunnels of Japan (mountain and subaqueous tunnels) and Norway (environmental and studded tyre dust pollution reasons) .

5.48 One way of overcoming the diesel smoke and dust problem, and avoiding intermediate fresh air shafts, is to filter out some of the smoke and soot by electrostatic precipitation, as is used in large air conditioning plants. Basically a precipitator consists of high voltage emitters and adjacent collecting electrodes. Most particles in the gas stream become ionised negatively and are therefore attracted to the positive collecting plates. Collected material has to be removed from the plates by either rapping the plates with flail hammers (if the material is dry), or by air or water blast. The Norwegian tunnels use hot water cleansing, those in Japan use compressed air. The filtering system is installed in a bypass at about 2 km intervals along the

tunnel. See Figure 5.4. Through flow velocities are of the order 7m/s and removal efficiencies are around 80%. Such filtering is hugely expensive to construct and run (air pressure loss is 1 to 1.5 bar). The system offers little benefit in the case of fire smoke control or gaseous pollutant removal (catalytic and biological methods are under investigation elsewhere for the latter). The additional power consumption, land take, materials consumed and disposal of waste products offer few environmental or sustainability benefits.

5.49 It is also possible, in theory, to use electrostatic precipitators to limit the amounts of smoke and soot discharged into the atmosphere, by cleaning a substantial portion of the exhaust air at tunnel portals and ventilation shafts and thus to reduce the impact of the tunnel on the local environment. The overall cost benefit and environmental benefit case would need to be studied to determine if such methods would be viable or even desirable.

Environmental Impact of Ventilation

5.50 For traffic on open roads vehicle emissions tend to be uniformly distributed. Tunnels, on the other hand, tend to concentrate vehicle emissions to apertures (portals and shafts) that link with the external atmosphere.

5.51 With the simplest form of longitudinal ventilation the polluted air is discharged to atmosphere from the exit portals. This should prove to be acceptable at most locations, particularly for rural tunnels.

5.52 The predicted effect of emissions from tunnel traffic on external ambient conditions and particular buildings located in the vicinity of a proposed tunnel shall be fully investigated. Nitrogen dioxide may be the critical gas for long term exposures. Atmospheric temperature inversion conditions shall be considered. Where the levels are in excess of acceptable limits it will be necessary to enhance dispersal of the polluted air discharge. For complex situations, environmental impact studies and/or wind tunnel tests may be necessary to consider dispersion. See also Chapter 2.

5.53 Where portal emissions have to be limited, ventilation extract shafts could be introduced to increase dispersal. These shafts, subject to any planning consent, may be located either close to the portals or at intermediate locations along the length of the tunnel, depending on the form of ventilation adopted.

5.54 Ventilation shafts will significantly reduce the impact at ground level by enabling dilution and dispersal

to be spread over a greater outfall height and distance. The location of such shafts may dictate the ventilation system (longitudinal, semi-transverse, fully transverse or hybrid) to be adopted.

5.55 Extract fan outlets shall be located so as to minimise impact on local inhabitants or the general public in accordance with relevant national, EC and WHO recommendations. In locating shafts account must be taken of their visual impact on the local environment. Fan noise may also be environmentally unacceptable and this needs to be taken into account in the design and location of fan buildings and ventilation plant and shafts.

Ventilation Effects of Tunnel Location and Form

5.56 At the planning stage, it should be borne in mind that ventilation requirements are affected by the location and siting of the tunnel. The orientation, absolute and relative datum levels of the tunnel will affect exhaust emission flow and levels of pollution. Incorrect geometry of portals and ventilation shafts may cause recirculation of polluted air or fire smoke. For coastal/estuarine tunnels the design and orientation of such shafts shall avoid intake of salt spray, particularly during adverse weather conditions.

5.57 Emissions will be increased for vehicles travelling up a gradient in a tunnel, and may be several times greater than those for level ground. Such inclines particularly affect large diesel engined vehicles carrying heavy pay loads. Conversely, emissions of pollutants generally decrease on descending gradients.

5.58 Vehicle engines operating at high altitudes emit more pollution than vehicles at sea level, since engine efficiency decreases with thinner air.

5.59 The arrangement of ventilation shafts and/or tunnel portals shall be designed to minimise the recirculation of polluted air or fire smoke back through the tunnel. In considering recirculation and pollution dispersal, the local topography and wind direction rose shall be considered. Recirculation increases the ventilation fan duty under normal conditions and introduces the potential risk of smoke logging in the event of a fire.

5.60 There may be conditions, particularly with strong winds, in which the air exhausted from one tube of a twin tube tunnel is drawn into the other tube, particularly if close together. Whilst this is undesirable it may be that the likelihood is low and that the tunnel ventilation system can still be controlled to maintain the required standards in both normal and emergency

situations. It shall be considered during the design stage and measures taken to avoid recirculation of polluted air and fire smoke into adjacent or non-incident bores. Procedures shall be put in place, to deal with any recirculation, so that the safety of road users is not endangered. Extending the central dividing wall at sufficient height for some distance (up to 40m) beyond the portal may reduce recirculation between adjacent entry and exit portals. More positive methods include staggering the portals longitudinally by some 50m, separating the portals transversely or using portal canopy extract fans. See Figure 5.5.

5.61 Where ventilation shafts are adopted, and the exhaust shaft is located adjacent to the intake shaft, their arrangement shall also minimise or prevent recirculation. Traditionally the exhaust shaft rises above ground to discharge vertically upwards as both vehicle polluted air and fire smoke are buoyant until cooled. The intake to the supply shaft is positioned closer to ground level and arranged such that fresh air is drawn in horizontally.

5.62 Longitudinal ventilation pressure heads need to overcome the drag of vehicles in the tunnel increased by the tunnel blockage effect, and reduced by convoy shielding effects, adverse winds, thermal chimney effect and the drag from the tunnel wall, protrusions, portal shape etc. Semi transverse ventilation systems with two way traffic have to overcome the overpressure zone between approaching trucks. Guidance is provided in PIARC documents and the most up to date advice shall be sought.

Junctions in Tunnels

5.63 The inclusion of junctions within a tunnel gives rise to additional considerations concerning ventilation. The effect of a junction will depend entirely upon the specific case, its location in relation to the main ventilation shafts, its size, its length and whether separately ventilated. It shall be considered from first principles.

Fire

5.64 Many fatalities as a result of a tunnel fire have been caused by inhalation of the products of combustion ie toxic smoke and hot gases. The first priority, for the safety of tunnel users, is to control the movement of the fire gases.

5.65 This Section shall be read in conjunction with relevant sections of Chapter 8 - Fire Safety Engineering.

5.66 Two factors adversely influence attempts to fight tunnel fires:

- i. Concentrations of smoke
- ii. Temperature and radiation conditions in the vicinity of the location of the fire.

5.67 Smoke removal is one of the most important factor in the rescue of tunnel users and facilitating the intervention of the emergency services. Ventilation equipment helps with smoke removal, and, by supplying fresh air which is relatively clear and cool, the evacuation from and access (for firefighting and rescue) to the location of the fire. The basis for dealing with emergency fire conditions is to provide sufficient airflow within the tunnel to move the heat and smoke away from persons who may be trapped and to leave a visibly clear access route for the emergency services. The required airflows are based primarily on consideration of the vehicle types allowed and consequent potential fire size and the type of ventilation system, including the position of any ventilation shafts. Various fire situations shall be simulated, to give an accurate picture of air velocity required in all sections of the tunnel.

5.68 When flames and combustion products reach the tunnel ceiling they will be deflected and elongated. Radiation of flames, and smoke from the ceiling, can cause skin burns and further ignition of flammable materials of adjacent vehicles ('fire jumping'). Low tunnel ceiling heights would worsen the situation and are to be avoided. Vaulted ceilings have the advantage of providing a higher zone for smoke escape, above any people below. It is important to control the spread of flames along the ceiling in order to prevent the fire spreading and to permit the emergency services a safer access to the seat of the fire. Lights, lighting diffusers, cables and tunnel linings above shall be non-flammable to remove a potential hazard to fire fighters below. Heavy items such as fans, subject to temperatures of 450C, should not fall during the firefighting period. Measures to reduce concrete spalling from concrete ceilings at 150+ C shall be applied.

5.69 To clarify the correct fire incident responses to design for, it will be necessary to define a range of fire scenarios with variations of location of incident and prevailing tunnel conditions. This is particularly important for tunnels where ventilation is provided by a number of balanced sections. The nature of the scenarios to be considered, and the appropriate ventilation response and control provisions, shall be established as part of the design process through dialogue with the emergency services and other relevant bodies at TDSCG meetings.

Types of Fire and Their Size

5.70 Fires in a road tunnel can be due to a number of reasons and vary in intensity according to their source:

- i. Private cars (engine, fuel tank)
- ii. Parts of heavy vehicles (tyres, brakes, engine, tarpaulins)
- iii. Entire loads of heavy vehicles catching fire
- iv. Accidents involving the transport of hazardous materials in general; certain hazardous materials may ignite following a collision or a fire in the vehicle itself.

5.71 Typical fire loads from single vehicles with non-hazardous cargoes range from 2.5 to 8 MW for cars, 15MW for vans, 20MW for buses, 30MW typical for a heavy goods lorry, 50MW+ for petrol tankers if significant spillages of fuel occur. Recent transport fires involving HGVs carrying "Non-Dangerous Goods" loadings have developed fire loadings that may have reached, or exceeded, 100MW. In very rare circumstances, petrol tankers could produce a fire load well in excess of 100MW depending on the number of fuel cargo compartments involved, rates of fuel drainage into tunnel system, time elapse before fire fighting starts etc. Where the integrity of a tunnel structure is vital then fires of up to 350MW have been designed for eg immersed tube tunnels below dykes in the Netherlands. Fire loads from multiple vehicle incidents leading to fire will depend on the physical locations of the vehicles involved and the rate of spread of fire. See Chapter 8.

Design Fire Size

5.72 The Overseeing Organisation will confirm the fire loadings to be assumed in the design of ventilation plant and structural protection for each new or upgraded tunnel, after submission by the Design Organisation of balanced proposals which take into consideration factors of traffic usage, response times, safety provisions and available accident statistics etc. Proposed provision shall include a risk assessment of the likelihood, balanced against the consequences, such as potential loss of life and risk of loss of tunnel structure, any consequent inundation, and any prolonged traffic disruption for repair. Unavoidable risk to life shall at no time be at levels greater than those accepted upon the open road or Government targets to reduce such risks. See Chapter 8.

Advance of Smoke Front

5.73 Without ventilation or still air, the layers of smoke from a fire would move, upstream and downstream, along the tunnel ceiling for distances of up to about 300m (dependant on fire size and tunnel geometry), before cooling and dropping down towards the road level. The air below the smoke layer remaining relatively clear and cool. The velocity of advance of a smoke front, from a vehicle fire, is related to the power output of the fire. The latter is governed by the size of the vehicle, the quantity and layout of combustible materials carried, and the rate at which the vehicle burns. It is also affected by the fanning effect of any forced or natural ventilation, including any chimney effect on gradients.

5.74 The initial velocity of smoke layer advance is about 1.3m/s for a 3 MW car fire and 3.0m/s for a 25 MW lorry fire, depending on the tunnel geometry. A petrol tanker fire of 50 to 100 MW could generate a smoke velocity of 7.0m/s or more, which requires large and high cost ventilation plant provisions to be able to cope successfully.

Control Air Velocity

5.75 The movement of the products of combustion in the tunnel can be controlled and directed by providing a flow of air with a velocity marginally greater than the critical control velocity. Critical control velocity is the longitudinal air flow velocity at which the advance of the smoke front is just halted for a defined steady state fire condition. The design ventilation capacity shall be sufficient to achieve this critical control velocity under the worst case design fire conditions.

5.76 Account shall be taken of the prevailing tunnel conditions and the fanning effect of ventilation. Most vehicle fires will generate smoke that can be controlled by a velocity of between 3 and 5m/s, depending on the tunnel geometry and type of ventilation system installed.

Fire: Smoke Control Strategies

5.77 The smoke control strategy adopted depends on the tunnel geometry, type of ventilation plant, traffic flow direction, escape arrangements, natural wind forces, the types of vehicle likely to be involved in incidents, their fire load and the ways in which the ventilation system can control smoke.

5.78 The strategies applicable to the main ventilation systems are illustrated in Figure 5.6 and discussed below:

i. No Mechanical Ventilation

Even if the wind and any remaining traffic movement could produce an air velocity sufficient to move the smoke front, the halted traffic, behind a fire incident, would be at risk of smoke logging by wind reversals, cooling and turbulence. Except for shorter tunnels, where the consequently short escape route distances provide both the most suitable means of quickly reaching safety, and sufficiently reduced access distances for the emergency services, tackling the fire and assisting any trapped persons, a lack of positive control of smoke direction is not acceptable, whether the traffic flows one or both ways.

ii. Longitudinal Ventilation Air Flow

For one way tunnels, fans should operate such that air movement is in the direction of traffic flow. This allows upstream traffic to drive out, and downstream traffic, trapped behind the incident, to remain smoke free. Further traffic (except of the emergency services) shall be prevented from entering the tunnel. Mobile traffic in the tunnel shall be directed to move out.

Layering of hot smoke in the tunnel ceiling (for a limited time and distance from the seat of the fire) allows people, within the relatively clear and cooler air below, to escape safely from the tunnel. Turbulence and cooling will cause such smoke layers to fall, at some distance from the fire. Unless the fans are started quickly, and at a moderate flow rate, the smoke may billow in all directions. An override smoke control, for fan operation, to be used only by appropriately trained fireman, shall be provided. Firemen will need to be informed of the current direction set for fans and, where necessary, the time it could take to reverse tunnel air flow completely.

Longitudinal fire ventilation is less safe in two way traffic, since smoke may be forced over vehicles approaching the fire in the non-incident lane. Scenarios need to be planned for in advance and the ventilation procedure, to best suit the actual situation, decided at the time.

iii. Transverse Ventilation Air Flow

Although costly to install and maintain, this is an effective system to provide safe escape for people over a lengthy period, and to remove smoke at and near the source of the fire. It is equally

effective for one way or two way traffic. Memorial Tunnel, Virginia, USA fire tests indicate that a longitudinal ventilation system gave the most effective control of smoke. The exhaust duct should be at the tunnel crown so that the buoyant hot smoke layer is extracted at high level.

iv. Semi-transverse Ventilation Air Flow

Since the whole tunnel space is the exhaust path the system is effective for one way traffic but less so for two way traffic.

Factors Affecting Ventilation System Performance

Meteorological Effects

5.79 Meteorological records for the area shall be obtained, so that the ventilation system performance can be assessed in the worst likely conditions of wind, wind direction, humidity and extremes of temperature. The effect of the immediate local topography shall also be considered. The designer shall consider carefully any effect that the weather may have on traffic flow, for instance on routes that carry a significant amount of tourist traffic where fine weather with high temperatures and light winds may induce more people to travel.

5.80 The cases to be studied shall include:

- i. Weather conditions adversely affecting the tunnel environment, and
- ii. Weather conditions adversely affecting the dispersion of airborne pollutants from the tunnel.

5.81 The former (i) is likely to happen at high wind speeds in excess of 10m/s and the latter (ii) at comparatively low wind speeds (often around 2m/s), the atmospheric stability shall not be assumed only to be neutral.

Precontaminated Air; Pollution Concentration Effect

5.82 The background levels of ambient air contamination shall be taken into account when assessing pollution levels. These levels shall be obtained by a local survey and applying appropriate design year predictions. Recent 1997 research (Environmental Transport Association Trust, telephone: +44 (0)1932 828882, www.eta.co.uk) carried out for Department of Environment, Transport and the Regions indicates that vehicles travelling towards the middle of the road, ie directly following other vehicles, suffer higher

concentrations of pollution than pedestrians or cyclists at the road sides. Concentration ratios for eg cars above background pollution levels, irrespective of vehicle ventilating systems, are in the range 4-5 for CO (carbon monoxide), 3 for NO₂ (nitrogen dioxide), and 4-6 for VOCs (volatile organic compounds). Account is taken in Table 5.2 of such concentrating ratios within road tunnels and the time road users will be within the tunnel confines. The relatively confined nature of the polluted air within the tunnel enclosure leads to a more even mixing than the open road. Tunnel pollution sensor readings will measure closer to the average pollution value at any one time. It is estimated that the correction for concentrating effect (with respect to tunnel sensor readings) will be achieved by reducing concentration values to half of that of the open air.

5.83 The levels assumed shall be clearly stated and agreed with the appropriate Regulating Authority eg. the local EHO (Environmental Health Officer).

Fans

Axial Fans

5.84 Axial flow main fans are used in ventilating major road tunnels. Capacities are typically in excess of 100m³/s. The large diameter fans are mounted in inlet or exhaust shafts, or in a plant room, supplying air ducts of a full or semi transverse system. Such fans supply or extract air for a complete tunnel section.

5.85 An axial fan, in which air passes between aerodynamically shaped blades to enter and exit axially to the direction of rotation. Reverse flow may be achieved by reversing the direction of rotation of the motor. An axial fan with blades set to be optimised for a specific flow direction will produce a reduced volume when the motor is reversed. Volume control and reversibility can also be achieved using fans with variable pitch blades.

5.86 Axial fans can be manufactured with individual blades bolted to the hub, so as to allow for limited blade angle (pitch) adjustment.

5.87 The driving motor can be mounted inside the casing, within the airstream, with an apparent saving in space, however, motor components will require access space for withdrawal during maintenance. Larger fans can have external motors and gearbox drives enabling individual components to be accessed more easily for maintenance and inspection.

5.88 Axial flow fans, at high pitch angles, may suffer an aerodynamic stall characteristic which occurs at low flow/high pressure conditions. Operation of a fan in conditions close to stall, results in pressure and power fluctuations, with the additional risk of excessive vibration leading to damage and fatigue. The fan design shall ensure that, under all duty conditions, a comfortable margin is provided between the operating point on the fan performance characteristic and the stall condition, or stall control measures incorporated into the design of the fan. Fans shall normally operate at their point of maximum efficiency.

Centrifugal Fans

5.89 Centrifugal fans have given excellent service since 1934 at Mersey Tunnel and are to be used in the major Boston Central Artery project USA, however, they are not normally suitable for modern tunnel airflow control as they require more space than axial fans of the same duty and reverse airflow can only be achieved by use of dampers and a reversing duct arrangement. Centrifugal fans have advantages over axial fans of being more efficient and less noisy.

Jet Fans

5.90 Jet fans are relatively small in output and size and can be housed in groups within the tunnel, spaced lengthwise in series, to give a multi-fan longitudinal air flow or at the tunnel entrance, as blowers. The fans are of the horizontally mounted, axial impulse type and maintain a longitudinal velocity of air within a tunnel. A jet fan increases the velocity of the air mass it passes through. The subsequent exchange of momentum between the high velocity jet (typically between 30 and 35m/s) and the slow moving air within the traffic space is utilised to maintain the required overall air velocity for ventilation and smoke movement. It should be noted that:

- i. Jet fans are not as efficient (10% loss over still air conditions) as axial fans operating in a ducted system. However, low capital cost and simplicity of installation and maintenance justifies their use, especially as a control system is not required to regulate the number of fans in use. Developments in new blade forms have efficiencies in excess of 70%.
- ii. The distance between fans in the longitudinal direction of the tunnel requires careful consideration. To prevent the flow from one fan reducing the performance of another they will normally be mounted at a minimum (without fan

- blade deflectors) of 10 hydraulic tunnel diameters (4 x ratio of cross sectional area and tunnel perimeter) apart or 6 to 8 diameters with 5 to 10 degree fan blade deflectors which allow more rapid momentum transfer. Siting of signing boards close to these distances should be avoided.
- iii. Fans shall be provided with anti vibration mountings which shall fail safe, eg by the provisions of safety chains, to prevent the fans falling onto traffic in the event of failure of a fixing. Vibration monitoring for determining service requirement purposes shall be considered. Care shall be taken to avoid galvanic and other corrosion of any fixings. Water entering a jet fan from washing activities etc will need to drain out and sealed for life bearings shall also be considered. Self cleaning blade shapes may be beneficial in reducing maintenance needs.
 - iv. Jet fans act by the combined effect of many fans. The design shall make provision, as described, for a loss of output from a certain number of fans (in maintenance and fire conditions) without jeopardising the overall minimum airflow.
 - v. Jet fans can be located at various places in the tunnel cross-section. They are most efficient when located at 3 fan diameters from a continuous surface. Fans in ceiling or wall recesses are not desirable for loss of ventilation efficiency (17% loss) reasons, and particularly at corner locations (31% loss) but may be justified economically compared with the alternative of higher civil construction costs, particularly for immersed tube tunnels. Deflector blades at the air jet exit can be beneficial in reducing energy losses at such locations. Inclining fans at a small angle (around 5-10 degrees) increases efficiency. For reverse flow, a facility to reverse the inclination angle would be required.
 - vi. The number of fan groups, their transverse alignment or staggering, together with details of any niche recess shapes, all efficiency losses, ensuring local re-circulation does not occur, cabling and maintenance requirements and any functional loss during a fire shall be assessed in a comprehensive ventilation study to balance initial, maintenance and operational costs for a given traffic flow and the probabilities of each critical scenario occurring simultaneously, and collective fan noise.

Fan Reversibility

5.91 Fans for tunnel air control shall be reversible for the following reasons:

i. One Way Traffic

Longitudinal ventilation by jet fans will normally be in the traffic direction and fan blades shall be set to achieve maximum efficiency in that mode. However, for twin bore tunnels in the event that one bore has to be closed, the bore in use may have either two-way traffic or one-way traffic in the reverse direction to the norm, and reversal of the fans is required. In this situation, fan efficiency is likely to be less than when operating in the normal direction and hence to produce the required velocity for smoke control more jet fans may have to be brought into use than would be the case for smoke control in the normal direction.

ii. Single Bore with Two Way Traffic

In contrast to the previous case, the predominant traffic direction may change twice or more each day. In such circumstances, depending upon tunnel length and prevailing wind conditions, it may be more efficient to reverse the fans so as to thrust in the direction of a predominant traffic flow. There is a need for operational measures to be implemented to prevent such fan reversals coinciding with a tunnel fire. Jet fans used in such circumstances shall deliver near equal thrust and efficiency in both directions.

5.92 Fan reversals should be kept to a minimum, as they introduce a period of high risk in being temporarily unavailable in the event of a fire. The time taken to completely reverse the air flow in a tunnel bore varies according to the characteristics of the individual tunnel and traffic conditions at the time, but may indicatively be as long as 20 minutes. In the interim smoke logging could occur.

5.93 Large axial fans mounted in shafts will either exhaust air, or, supply air, but will not be required to change direction and need not be reversible except in push-pull longitudinal systems. The possible exception is an axial fan supplying ducted air at high level in a semi-transverse system where, in a fire emergency, it may be necessary to reverse the fan and extract smoke, however, the blades should be set for maximum efficiency in the normal direction, provided at least 70% of normal throughput is achieved in the reverse direction, and that

this reduced throughput is adequate for smoke control. In the unusual circumstances that a reverse flow of equal value is required then the fan blades must be designed accordingly and the motor size increased to allow for the permanent drop in fan efficiency.

Fan Speed and Reversal Control

5.94 For the majority of tunnel applications, jet fans are single speed, reversible, with soft-start or star-delta starters to reduce starting currents. Control of multiple fans from one starter is not good practice. For economy, groups of fans may be connected to a single control panel, with individual switches to dedicated fan motor starters. Longitudinal ventilation air volume control is normally regulated by varying the number of jet fans in operation.

5.95 Starting of fans shall be sequenced to reduce the peak load demand on the power supply and to facilitate up to 6 stages of ventilation, if required.

5.96 Jet fan motor characteristics shall be such that the fan shall be able to accelerate from standstill to full forward running speed in not more than 5 seconds, and achieve full running speed in the reverse direction within 30 seconds of being switched from the forward direction. Motors shall be capable of undertaking 10 starts per hour, in either direction, with up to 1 start and 2 reversals in a minimum of 10 minutes.

5.97 Jet fan motors are typically rated at up to 75kW, whereas, large axial fans are commonly rated at up to some 10 times higher and consequently require more sophisticated starting and output control devices. The preference is for variable speed control, rather than the less efficient blade angle variation, to control air output. With variable speed control, by frequency converter consideration shall be given to matching gearing with motor thermal characteristics and the control circuits shall maximise power factor. Such control has the advantages of 'soft start' (important with loads of say 300kW and above) and low fan noise level at the normal, low speed, operation. Blade angle variation does not give comparable noise reduction at reduced fan output, but maintains high fan and motor efficiency.

Jet Fan Aerodynamic Performance

5.98 The specification of each jet fan shall be expressed in terms of the minimum actual thrust, in both directions, produced in standard air (ie. atmospheric air having a density of 1.2 kg/m³) in a still atmosphere. The minimum fan exit air velocity shall also be specified. Performance requirements for fan thrust and exit air velocity are to be proven in works tests.

Fire Rating and Testing of Fans

5.99 All electrical and structural components essential to the continued operation of ventilation fans (located within the tunnel bore) shall, in the event of a fire, be suitable for operating in smoke-laden air at a temperature of 250°C for 2 hours. The system shall be designed to prevent failure of a fan (or its associated equipment) leading to a system failure of the remaining, otherwise serviceable, fans. Electrical supplies to fans within the tunnel shall be dualled.

5.100 There is not a specific standard for fire testing of tunnel fans, although CEN PREN 12101-3: Smoke and Heat Control Systems: Part 3: Specification for Powered Smoke and Heat Exhaust Ventilators is being expanded to include for jet fans. Any proposed test procedures used to demonstrate suitable fire resistance in operation shall be subject to agreement with the Technical Approval Authority of the Overseeing Organisation, in accordance with the following advice:

i. *Jet Fans:*

The fire test may comprise a ducted recirculation system, with a heating element within the circuit. Once 250°C is reached at the fan inlet, the 2 hour test can commence. During the test period there shall not be any significant reduction in fan performance nor failure of any essential component, including silencers. For reversible fans these shall be reversed at least once towards the end of the test period. The test is considered to be destructive and, subject to agreement, a manufacturer's 'type test' certificate may be acceptable if equivalent performance has been previously demonstrated.

ii. *Axial and Centrifugal fans:*

The temperatures (notionally 200 - 250°C) and duration (notionally 2 hours) for which such fans on extracting duty are required to operate will differ for each fire scenario considered, location of fire and cooling effects over distance to fan location and content of fresh air within the flow. The Design Organisation shall determine the appropriate fire rating for the fans through modelling. Destructive fire testing of such fans is not required provided the manufacturer is able to demonstrate, that the proposed fans are adequately rated.

Noise

General

5.101 Ventilation equipment can be a major source of noise in tunnels and therefore limitation of noise emission is an important factor in the choice of fans. Acoustic treatment by means of inlet and outlet silencers and/or casings with sound absorbent lining may be required in order to reduce the amount of fan noise transmitted to the outside environment.

Plant Design: Noise

5.102 Careful attention to plant detail design will achieve the required sound levels at lower cost to the end user than the use of sound attenuating equipment. The sound power level of a fan increases very rapidly with increasing tip speed. For a given volume of air, a larger and slower rotating fan will be quieter (but more susceptible to stall). Similarly, reductions in mechanical noise can be achieved from efficient design of motor couplings, driving gear, adequate stiffening of the casing, etc. Reduction in vortex noise is obtained by careful duct design with the minimum amount of turbulent flow from sharp bends, obstructions etc. Mounting of machinery on insulated entablatures will reduce transmission of noise and other vibrations through the ground.

Jet Fans: Noise

5.103 For jet fans, additional sound absorbent material in the fan casing, and inlet or outlet silencer shall be considered. Any increased head loss caused by a silencer, in some designs, can only be compensated by increased fan energy consumption and hence higher potential noise levels. Lower jet velocities of 20m/s are quieter but increase the size and number of fans. A balance has to be determined by the Design Organisation.

Noise Levels

5.104 The control of noise to the outside environment will depend on individual circumstances and the area background noise levels during fan operation. In the case of an external ventilation building, it will be appropriate to specify the maximum installed noise and vibration levels at 10 m from the building. See also BS7445, BS8233 and BSEN1793.

5.105 Care shall be taken that the fan noise levels in the tunnel, particularly at times of emergency fan use, are not so high as to interfere with the use of emergency

communication systems. A maximum level of NR85 shall be specified in the tunnel at a plane 1.5m above the road surface.

Tunnel Pollution

5.106 The major factors affecting the extent of vehicle pollution within and from road tunnels are as follows:

- i. Form of tunnel ventilation used
- ii. Pollution control limits within the tunnel - ie for CO, NO_x (a mixture of nitric oxide and nitrogen dioxide gases) and visibility
- iii. Tunnel geometry eg gradients, length and cross section of bores
- iv. Evolving laws on fuels and permissible vehicle emissions and the age of vehicles
- v. Average distance vehicles travel from a cold start before reaching the tunnel
- vi. Wind direction and strength in respect of both the influence on the ventilation system and the dispersal of polluted air from the tunnel
- vii. Traffic flow characteristics and risk of congestion leading to inefficient combustion, loss of piston effect and reduced air flow from blockage caused by large, slow moving vehicles
- viii. Altitude.

Tunnel Form

5.107 The form of ventilation shall be resolved to suit the specific tunnel site concerned. The trend is to use longitudinal ventilation in its basic form (ie no shafts) wherever practical. For two way flow, two one way traffic bores are preferred, and may be essential from a health and safety point of view.

5.108 Any inclusion of ventilation shafts or other forms of ventilation shall be based on established environmental, safety, planning and operating criteria.

Tunnel Design Year

5.109 The design year is nominally the planned year of opening the tunnel to traffic. However, where traffic levels are expected to rise with time, design years may be determined as up to 10 years after the year of

opening. The design year assumed is relevant in determining the fresh air requirements to maintain tunnel air quality.

Traffic: Influence on Ventilation Requirements

5.110 Average vehicle emission rates for each class of vehicle will vary according to speed and gradient. Traffic speed, density and composition are material to determining the fresh air requirements in tunnels and the extent to which forced ventilation is required.

5.111 The piston effect of free flow traffic can reduce any forced ventilation needs by keeping the traffic speed above 30km/hr. The ventilation system's energy consumption will be reduced and may limit the ventilation demand to that required for fire smoke control purposes.

5.112 The scope to implement traffic control procedures, to ensure free flowing traffic, shall be established at outline design stage. Recognition shall be given to the implications of such measures on the surrounding traffic flows. Where appropriate, such proposals shall be supported by a regional traffic assessment.

Fresh Air Requirements: Calculation Method

5.113 The designer shall take into account relevant international developments in determining the calculation method to be applied.

5.114 World Roads Association, PIARC represents the international consensus on the practical application of current scientific and technological developments for road tunnels.

5.115 PIARC 1995 Tunnels Committee has published Road Tunnels: Emissions, Ventilation, Environment. The document includes the findings from a joint international research effort into actual vehicle emissions under simulated travelling conditions and improved methods to calculate the fresh air requirements for ventilation.

5.116 Establishing appropriate data for a specific tunnel remains, however, the responsibility of the Design Organisation.

5.117 Table 2.2 of PIARC 1995: Road Tunnels: Emissions, Ventilation and Environment provides values for average peak traffic densities for both one and two way traffic flows at 0, 10 and 60km/hr. Values shall be applied with due consideration given to the particular

tunnel and TD20 Appendix 2 (DMRB 5.1.3) and TA46 (DMRB 5.1.4).

5.118 Passenger car units (pcu) shall be converted according to the method given in PIARC 1995: Road Tunnels, Emissions, Ventilation Environment: Section II: Passenger car units.

5.119 The traffic composition shall be determined for each case. However, in the absence of more precise traffic data, it may be assumed that 15% of the total traffic consists of diesel powered heavy goods vehicles with equal proportions of 10, 20 and 30 tonne units.

5.120 Fresh air ventilation requirement shall be designed for, for worst case congested traffic conditions (typically at, or below, 10km/hr traffic speeds for longitudinal ventilation) and for free flowing traffic. Peak traffic density often occurs at around 60km/hr.

5.121 Fresh air calculations shall consider traffic speeds of 0, 5 and 10km/hr and, thereafter, speeds increasing by 10km/hr up to the design speed limit. This will allow the maximum fresh air ventilation duty and the worst case tunnel portal and/or shaft emissions to be determined. A partial exception could be where traffic control provisions prevent slow moving congested traffic from occurring.

Vehicle Emissions

5.122 A quantitative assessment of vehicle emissions for the tunnel during its design year shall be made using the levels described in PIARC 1995: Road Tunnels: Emissions, Ventilation and Environment. Additional allowance, for a particular tunnel site, shall be made for the increased pollution levels over ambient background levels within vehicles, as reported by the Environmental Transport Association Trust, 1997. Typical ratios of average concentrations to background levels for cars have been given as 4 to 5 for CO, 3 for NO₂ and 4 to 6 for VOCs (volatile organic compounds).

5.123 The main air pollutants from road traffic include carbon monoxide (CO), diesel smoke, particulates, oxides of nitrogen (NO_x), sulphur dioxide, hydrocarbons and lead. The most significant of these are:

- i. Carbon monoxide from petrol and diesel engines
- ii. Smoke (carbon particles) particularly from larger diesel engines
- iii. Oxides of nitrogen (nitrogen monoxide and nitrogen dioxide).

5.124 Petrol engine exhaust contains a relatively large amount of carbon monoxide compared to diesels. However, heavy goods vehicles with their larger diesel engines may emit similar quantities to a petrol engine car.

5.125 Emissions such as sulphur dioxide and hydrocarbons are relatively low in toxicity, and constitute a small proportion of the total vehicle emissions. It can be safely assumed that adequate dilution for these will be provided for by the ventilation system controlling either carbon monoxide or diesel smoke, whichever is the greater requirement at the time.

5.126 Emissions of lead although highly toxic are no longer considered to be a design consideration due to the greatly increased use of unleaded petrol and the requirement that from 1990 all new cars must be capable of running on lead-free fuel.

5.127 Changing legislation for engine emissions and fuels lead to changing emission qualities and quantities. The full effects take time as older vehicles and fuels gradually disappear from use.

5.128 Carbon monoxide and diesel smoke will become less important relative to oxides of nitrogen.

Carbon Monoxide

5.129 Emission rates are given for light and heavy duty vehicles, with relative rates for different years, the gradient factor and the altitude factor.

Diesel Smoke

5.130 The most apparent effect of diesel smoke is to reduce visibility in the tunnel. Even low levels of haze give tunnel users a misleading impression of a poor atmosphere.

5.131 In urban tunnels, the base smoke (particulate) emission from a heavy goods vehicle shall be taken as 100 m²/hr, at 60 km/hr. For longer distance routes, where the proportion of heavier vehicles is greater, 160 m²/hr shall be used.

5.132 Current legislation on diesel smoke is expected to lead to a reduction in particulate emissions from heavy goods vehicles.

Oxides of Nitrogen

5.133 When calculating the emission of oxides of nitrogen it shall be assumed that the initial emission is solely NO (nitric oxide) and that this subsequently

converts to NO₂ (nitrogen dioxide) with a half life of one week. Some conversion may occur rapidly, within a tunnel, in the presence of ozone. The rate of NO conversion depends on complex factors including, oxygen levels, presence of other gases and particles, temperature and exposure to sunlight.

5.134 Values for the percentage of NO₂ in total nitrogen oxides (NO_x) are not certain but may lie between 10% (heavy traffic) and 20% (light traffic) in tunnels. At design stage, the latter figure should be used, as conservative, in the absence of firm data from similar tunnels.

5.135 The toxicity of NO₂ is five times that of NO and any conversion to NO₂ tends to increase the overall toxicity of the tunnel atmosphere. Control of NO₂ levels is by either monitoring for such, or imposing reduced CO levels. Tunnel sensors (other than personal monitors) to measure low concentrations of NO₂ are not yet believed to be fully reliable. An estimate from NO_x measurements is recommended at present.

5.136 Emission rates are given in PIARC 1995: Road Tunnels: Emissions, Ventilation and Environment, with relative rates for different years for light duty vehicles and heavy duty vehicles. See, also, Table 5.5.

Lead

5.137 Because of the reduction in the amount of lead in leaded petrol and the increasing use of unleaded petrol, lead emissions are no longer considered in road tunnel ventilation design.

Oxides of Sulphur

5.138 The emission of sulphur dioxide (SO₂) can be calculated as a proportion of the carbon dioxide (CO₂) emission.

Carbon Dioxide

5.139 Carbon dioxide emissions, while important for their overall effect on the atmosphere, are not a problem for tunnels. However, calculation of CO₂ levels may be carried out as CO₂ emission is directly proportional to the amount of fuel burned and is therefore a useful way of assessing the levels of pollutants such as lead and SO₂.

Pollution Limits (Tunnel Interior)

5.140 The limits, given in Tables 5.1 to 5.3, are based on PIARC 1995: Road Tunnels: Emissions, Ventilation and Environment and Health and Safety Executive

(HSE) document EH40: Occupational Exposure Limits (editions are regularly updated) recommendations and are applicable for new design or refurbishment purposes.

Vehicle Age and Emission Laws

5.141 In order to apply the calculation method recommended by PIARC 1995: Road Tunnels: Emissions, Ventilation and Environment, it is necessary to understand the history of the vehicle emission laws and their impact. It is also necessary to establish the age profile of the vehicles in the traffic flows concerned.

Emission Laws

5.142 European and UK emissions legislation for new vehicles has evolved over recent years leading to a reduction in the levels of emissions permitted. It is important, when predicting emissions, to take into account the legislation in force when the actual vehicles were manufactured. A history of the various emissions standards and their dates can be found in Fact Sheets 1 and 2 published by the Department of Transport Vehicle Standards and Engineering Division.

Vehicle Age

5.143 Renewal of vehicles needs to be estimated for the particular area concerned. Table 5.4 provides an indicative age spectrum for a national fleet, that reflects the finding of PIARC 1995: Road Tunnels: Emissions, Ventilation and Environment.

Cold Start Factor

5.144 A cold start factor needs to be applied to address the additional emission to be expected from vehicles with catalytic converters that operate most efficiently at higher engine temperatures as well as the normal cold engine inefficiencies. The factor is more relevant to urban areas where possibly 10 to 30% of local vehicles may not have attained full working temperature on entering the tunnel.

5.145 In assuming the cold start factor to be applied, due consideration shall be taken of the tunnel location and the forecast traffic flow conditions during peak traffic periods, particularly for the winter.

Traffic Weight Influence

5.146 The average weight of goods vehicles reflects the amount of emissions for a given traffic composition. PIARC 1995: Road Tunnels: Emissions, Ventilation and

Environment reports the typical weight ranges of Table 5.5, but the average weight to be assumed shall be deduced from the peak traffic forecast for the particular tunnel.

External Environmental Conditions

5.147 Ambient air standards for the environment outside of a tunnel are given in Environmental Assessment: Air Quality: Table 5 (DMRB 11.3.1). These standards apply to longer term exposures than for those passing through road tunnels and shall be met at the nearest inhabited building which is not part of the tunnel operation or 100m from the portal, whichever is the lesser. See also Chapter 2.

5.148 The 8 hour CO concentration which may be exceeded once a year, C_x , can be calculated by:

$$C_x = 1.19 + 1.85 C$$

Where C is the maximum predicted 1 hour concentration.

5.149 There is no ambient air limit set for NO. The predicted NO concentration should either be doubled then added to the CO concentration, and the CO limit applied, or it should be treated as having been fully converted to NO₂, and the NO₂ limit applied, whichever is the more onerous. Two of the objectives of the National Air Quality Strategy limits for NO₂ are to achieve by Year 2005 an hourly mean of 150ppb (parts per billion) and an annual mean of 21ppb. The objectives apply in non-occupational near-ground level outdoor locations where a person might be reasonably expected to be exposed over the relevant averaging period. They do not apply for drivers within their vehicles, whether travelling inside or outside of a road tunnel.

5.150 As a guideline for outside of a portal, 50% of the NO produced in a tunnel should be taken as having been converted to NO₂. For exhaust shafts, the conversion should be assumed to be 60%.

Occupational Exposure Limits for Staff in Tunnels or Toll Booths

5.151 Standards and limits for occupational exposure are given in the latest HSE document EH40: Occupational Exposure Limits (editions are regularly updated). Extracts are given in Tables 5.6, 5.7 and 5.8 for illustrative purposes. These standards are for persons at work at a tunnel site and differ from the longer term

ambient standards and those for the more sedentary driving through a road tunnel over a normally short time period.

5.152 The exposure of persons working near the tunnel portal, eg toll booth attendants, shall be assessed under the meteorological conditions which would produce the highest pollution levels at the points under consideration, for both short (15 minute) and longer term (8 hr) exposure. It may be necessary to provide air conditioning in toll booths. Staff who are smokers may already have high CO levels in their bloodstreams before entering a tunnel.

5.153 When calculating the longer term exposure levels, it shall be assumed that the traffic flow over 8 hours is 6.5 times the maximum hourly flow.

5.154 Standards for lead in air are set out in Appendix 4 of EH40.

Ventilation System Safeguards

5.155 The vital importance of ventilation for the health and safety of tunnel users is well recognised. Failure of a mechanical system could cause the tunnel to be closed to traffic. Closure could cause severe disruption to traffic over a wide area with serious consequences. All reasonable safeguards must therefore be built into the ventilation system to avoid unplanned tunnel closure or undue restrictions on traffic flow. Duplication of essential equipment will facilitate maintenance work, planned or unforeseen, and limit disruption to normal traffic flow. The main features to provide safeguards for, or build in redundancy are described.

Electricity Supply and Distribution

5.156 Two high voltage (HV) supplies, generally at 11kV and derived from separate sources, are required to ensure maximum security of the power supplies. See Chapter 11. Each supply shall be separately and evenly distributed throughout the tunnel, including supplies to jet fans, to fans in inlet/outlet shafts and to fans in ducted transverse systems.

Fan Operational Security

5.157 The ventilation system shall be designed to operate to its design requirement even when a fan is unavailable either due to routine maintenance or occasional failure. In order to accommodate this, it will be necessary to provide a level of standby fans in order to give an acceptable level of redundancy. The proportion of jet fans assumed to be out of service for

maintenance could be greater for short tunnels. Conversely, the proportion of jet fans destroyed by fire in a longer tunnel should be less than for a shorter tunnel. Generalised guidance is as follows:

i. *Jet Fans:*

Fan redundancy levels to be assumed for design purposes shall be determined according to the specific tunnel concerned. The following may be considered as indicative:

a. Normal operations: 2 fans or 10% of the fans (to the next whole fan number), whichever is the greater, shall be considered to be out of service.

b. Fire situation: In addition to the fan redundancy level assumed under normal operations, fans within the distances from the seat of a fire indicated by Table 5.9 shall be considered to be destroyed:

ii. *Axial or Centrifugal Fans:*

Fans shall be arranged on a duty standby arrangement such that switching from one fan to another occurs automatically. Where more than one fan serves a particular duty, only one standby unit is required.

5.158 With jet fan systems extra units may be held in store, ready for immediate installation using purpose made cradles and vehicle mounted working platforms. A suitable stores holding could be 5% of the total number of jet fans installed, with a minimum holding of three. For guidance, a typical tunnel may have some 40 jet fans per km length, per bore.

5.159 Non-jet fans (large axial or centrifugal fans) should normally have 100% standby capacity. The standby fan or fans may be permanently installed with dedicated ducting. Alternatively each fan could be mounted on a trolley and the fans changed by disconnecting the duty fan, traversing it across the duct and connecting the standby fan.

Air Monitoring, Ventilation Control

5.160 The measurement of carbon monoxide and visibility levels currently form the basis of control for ventilation. In the near future, as carbon monoxide levels continue to fall and air opacity clears then nitrogen dioxide etc levels may need to be used for ventilation control and values are given in Table 5.2 for guidance for new tunnel design and refurbishments. A logical

method for control shall be developed, which caters for normal and abnormal operations, and safeguards the fans from frequent switching. Control of the ventilation system shall be an integral part of the tunnel operating procedures. See Chapters 10 and 14.

5.161 Instruments for measuring carbon monoxide and visibility level shall be located adjacent to the tunnel traffic space, at each position where a maximum level of pollution (or minimum visibility) is anticipated. Access for maintenance shall not be hindered. Fans will normally be automatically controlled by signals from these instruments. In certain instances, eg exposed tunnel portals, the tunnel air velocity may also be used as a control parameter. Other methods include counting vehicles and detection of congestion via CCTV.

5.162 Sampling stations should be positioned, ideally, at the general level of vehicle air ventilation inlets. This ideal is not practical for instrument types depending on beam transmission where vehicles (particularly if stationary) could shield the beam. The latter instruments should be positioned at about 2 to 3m height from the road level. It is common practice for the instruments to be installed over the tunnel verges for ease of access and be located within wall recesses or secured to brackets or roof mountings. However, to avoid false readings, the measurement beam shall not be located so as to pass through the immediate vicinity of fresh air inlets or air close to jet fans. Instruments shall be calibrated to represent the average air quality within the tunnel.

5.163 Electronic instruments, particularly those with optical components, are sensitive to environmental conditions normally found in road tunnels i.e a damp, possibly saline, acidic, cold and dusty atmosphere, subject to air velocities up to 10m/s. Tunnel washing procedures often involve use of high pressure water sprays and aggressive chemicals and detergents which could have an adverse effect on electronic equipment. Therefore, special attention is necessary for the design and construction of the instrument enclosures and mountings. Protection shall be to at least IP65.

5.164 Monitoring systems (including a backup monitoring station) shall be provided and all operational data recorded and stored for analysis. Data includes pollution levels, tunnel air speed, fan operations and any alarm states. Plant monitoring and control shall be based on the use of PLCs, microprocessors or computers, depending on the size and complexity of the facility. Programmable Logic Controllers (PLCs) have proven to be more reliable.

5.165 Signals from the instruments shall also be transmitted to a manned control centre, where emergency procedures can be initiated should any readings exceed the allowable limit. Operation of special fan regimes will be necessary to deal with incidents involving a fire in the tunnel and will normally be carried out from the manned control centre.

SCADA System for Ventilation

5.166 A primary objective of the SCADA (Supervisory Control and Data Acquisition) system is to ensure a safe environment for tunnel users under a wide variety of operating conditions. Functions for ventilation are discussed in Chapter 10.

Measurement of Carbon Monoxide Concentrations

5.167 Instruments for measuring concentrations of CO shall cover a range of 0-300ppm.

5.168 In a longitudinally ventilated tunnel at least three sampling points would typically be provided to make allowance for two way flow in the tunnel, even if normal operation is one way. The location of sampling points shall avoid dilution by air circulating from the portals. A monitoring station (regular and back up instruments) shall be located at about 50m inside from each portal, with the third station typically positioned at the centre of the tunnel. The regular and back up instrument points should be located close together, for ease of maintenance. The specific arrangements shall be determined from pollution and ventilation calculation.

5.169 In semi transverse and transverse ventilation systems the sampling stations are located at each position of maximum concentration, as established by calculation. Two points per ventilation section are generally sufficient, one being a backup for the other.

5.170 Currently, measurement of carbon monoxide concentrations uses an infra-red absorption technique. Instruments compare the absorption of certain infra-red wavelengths when passed through a tunnel atmosphere, with that through a cell containing carbon monoxide. The equipment is accurate and requires low maintenance.

5.171 Carbon monoxide concentration could be measured by catalytic oxidation and electro-chemical analysis but these methods are not suitable for long term use in tunnel environments.

Measurement of Visibility

5.172 There are three types of instrument available for measuring reductions in the range of visibility. The type in current use in most UK tunnels is the Transmissometer which measures light transmittance. It consists of two basic units, a transmitter and receiver, with or without a reflector depending on type, which can be fitted outside of the traffic envelope. The clear distance between the measuring head and the receiver/reflector is normally a minimum of 2m but can be up to 50m. Visibility is assessed by measuring the variation in light power transmitted over a base length.

5.173 Reduced visibility can also be measured by means of diffused light measurement (opacimeters) and light scatter measurement (nephelometers). To date, both methods have given rise to operational problems within a tunnel environment and are not recommended.

5.174 Instruments are usually set for zero obscuration (maximum transmittance). Most instruments provide auto calibration facilities to allow for contamination of the optics, using intermittent mirror reflecting and/or time-variant software compensation.

5.175 Visibility is expressed in terms of the Extinction Coefficient, K (units m^{-1}). Extinction is typically defined as the rate of attenuation (reduction) of light intensity along a path length. $K = -\log_e(I_o/I_x) / X$, where I_o and I_x are the light intensities at the start and end of a path length X metres. Approximate visibility distance $D(m) = 2/K$ for reflecting signs, and $D(m) = 6/K$ for illuminated signs. Visibility of illuminated signs through fire smoke is down to below 15m when $K = 0.4$. Evacuation walking speed greatly reduces when visibility reduces below 7m.

5.176 Instruments will normally be located in conjunction with those for monitoring of carbon monoxide and will have similar standby arrangements.

Measurement of External Wind Speed and Direction

5.177 Wind speed is usually measured using a vane type anemometer.

5.178 Wind measurement devices may also be necessary in the case of exhaust air shafts if such shafts are near pollution sensitive areas. By monitoring wind velocity and direction, the tunnel air expulsion velocity shall be adjusted so that the polluted air plume carried away by the wind does not affect pollution sensitive areas.

Measurement of Tunnel Air Velocity

5.179 In the case of longitudinal ventilation with two-way traffic or where there are known to be strong prevailing winds, measuring devices may be needed to determine the wind's influence on the tunnel ventilating airflow. Air velocity monitors situated within the tunnel can observe such effects. Wind effects are of particular importance for short tunnels ie those up to 500m long.

5.180 Anemometer, ultrasonic flow or orifice plate devices shall be installed in the tunnel to give a reading of the tunnel air direction and velocity to the control room. The range shall be 0 -15 m/s in either direction with an accuracy of ± 0.5 m/s.

5.181 The instrument may be placed at any suitable location within the tunnel outside of the traffic space and not within 50m of either portal. Non-ultrasonic instruments placed close to the tunnel wall shall be corrected for boundary flow conditions.

5.182 In cases where the external wind is sufficiently strong to make the operation of jet fans ineffective, it is desirable to use the condition as a control parameter to reverse the direction of their operation.

Fan Control in an Emergency

5.183 An emergency condition will normally be detected by the traffic control centre from the public emergency telephones, CCTV cameras etc. Traffic control are responsible for alerting the tunnel operator to provide control of the ventilation

5.184 In an incident involving fire an assessment shall be rapidly made of the size and location of the fire, and the fans operated in the mode best suited to the particular conditions. See Chapter 8, including for information on smoke control panels.

5.185 Vehicle occupants shall be evacuated from the side of the fire to be used for smoke clearance as a matter of urgency.

5.186 In the case of a fully transverse system, the fans shall be switched to full extract as soon as fire is detected. In a semi transverse system, depending on circumstances, but particularly if the ducting is at high level, the fan normally supplying the input ducting may be reversed to extract smoke until people have been evacuated, after which, normal longitudinal extract airflow shall be resumed.

Operating Arrangements

5.187 Operation of ventilation plant is an essential component of the overall framework set up to operate each tunnel on a day-to-day basis, execute planned maintenance, control tunnel traffic pollution and respond to tunnel emergencies depending on the particular circumstances and deal with a wide range of issues affecting safety and economy.

Toll Tunnels

5.188 In the particular case of a major toll tunnel, permanent staff dedicated to the operation of the tunnel complex will be provided.

Free Tunnels

5.189 More generally, tunnels on motorways or other trunk roads will be designed to operate automatically and unattended. However, there must be a rapid response in the event of equipment failures or other emergencies. For the ventilation aspects this requires that the TOA responsible for the tunnel have adequate plant and equipment and a nucleus of trained staff who are fully familiar with the operation, inspection and maintenance requirements of all ventilation equipment and are capable of providing advice and assistance to the emergency services in the case of a fire.

5.190 TOA staff shall provide emergency cover on a 24 hour basis, are required to oversee all maintenance work (including that contracted out) eg replacing jet fans, cleaning exhaust ducts, and, where necessary, include qualified and authorised personnel to comply with statutory safety procedures, with permit-to-work limitations in certain areas such as electricity supply or with safety rules and procedures for entry into confined spaces.

5.191 The emphasis that needs to be given to these various considerations shall be brought out in the manuals to be prepared as tunnel documentation. See Chapter 13 and Appendix C.

System Upgrade

5.192 A tunnel ventilation system or major parts of it, are likely to have a practical and economic life of 15 to 20 years. Practical difficulties arise as plant becomes outdated, the original manufacturer may no longer be in business, or have jigs, tools and spares available. The costs of repairing or refurbishing old plant can become prohibitive, particularly if spares have to be specially

made. Decisions will then need to be made as to whether a major system upgrade is the best way forward.

5.193 The main reasons for a system upgrade or replacement are:

- i. The ventilation performance is inadequate to meet the current environmental and emergency condition needs (the original design may have proved inadequate in operation, standards have become more demanding, or traffic more congested or its component mix changed).
- ii. Repairs have become unacceptably difficult and costly.
- iii. A Civils Work refurbishment is necessary which affects mechanical and electrical equipment and makes a total upgrade the most economic way forward rather than accept a second major disruption to tunnel availability soon after the first.

5.194 A ventilation system upgrade will be preceded by a principal inspection to BD53 (DMRB 3.1.6) that will take into account the TOA views from operational experience, the performance and condition of plant, the likely costs, timescale and operational arrangements involved in an upgrade and the overall view of an independent review body.

Extent of an Upgrade

5.195 As the term implies, an upgrade is not replacing like with like, but providing a ventilation system to comply with the current standards that would apply for a new tunnel. Complete renewal may not be necessary if ventilation performance is adequate. Major items of equipment could be refurbished if it is economic and operationally feasible, eg for motors, fan blades, bearings, silencers, dampers, etc. Jet fans or a reserve main axial fan could be released for works reconditioning to an agreed schedule. However, after some 20 years life, some older cable types and most electrical controls would probably need to be replaced. Modern cable types may last for 50 years or more.

Disruption to Traffic

5.196 If a ventilation upgrade is part of a more extensive programme involving civil works, then at least one tunnel bore may have to be closed either entirely, or part-time (nights, weekends etc), with a detailed plan of work and safe opening/closing procedures to be rigorously followed. New cabling and switchgear could

be installed as traffic movement allowed with final connections, changeover and testing during planned closure periods.

5.197 Contractor's operations and permits to work will be controlled by the TOA. Because of the national

economic importance of maintaining traffic flow, and in the case of toll tunnels the loss of revenue when closed, penalty clauses for late handback against formal programmes should be considered for inclusion into works contracts.

Traffic Situation	CO limits [ppm]
Fluid peak traffic, above 50 km/h	100
Daily congestion, standstill all lanes	100
Seldom congested	150
Tunnel closure necessary	250

Note: PIARC 1995: Road Tunnels: Emissions, Ventilation and Environment gives lower values for Design Year 2010. Traffic control to prevent congestion will reduce ventilation cost, particularly in long tunnels. Visibility or NO_x limits may govern as modern engine systems and fuels reduce harmful emissions. Table 5.1 has been used for recently constructed UK Tunnels and is included for reference only. It does not distinguish, for pollution exposure times, between different tunnel lengths. Table 5.2 is to be used for design and control purposes.

Table 5.1 Reference Only: PIARC Carbon Monoxide Limits (Design Year 1995)

Substance	Application	Type	Tunnel Sensor Limit Level	EH40 Level
CO Carbon Monoxide	Tunnel Road Users	<i>Short-term limits:</i> Fifteen minutes, or less, average exposure	A: 100ppm B: 50ppm C: 35ppm	200ppm
NO Nitric Oxide	Tunnel Road Users	<i>Short-term limits:</i> Fifteen minutes, or less, average exposure	A: 30ppm B: 20ppm C: 10ppm	35ppm
NO ₂ Nitrogen Dioxide	Tunnel Road Users	<i>Short-term limits:</i> Fifteen minutes, or less, average exposure	A: 4ppm B: 3ppm C: 1.5ppm	5ppm

Notes:

1. EH40 Occupational Exposure Limits are set with thresholds below which, on existing knowledge, there are thought to be no adverse effects on people. In the absence of more specific scientific data, the values have been conservatively adapted for road users within tunnels.
2. With respect to EH40 levels, tunnel sensor limit values allow for pollution concentration for in-vehicle road users as described, and time of exposure with respect to length of tunnel for congested traffic, travelling at 10km/hr. Tunnel sensors shall start mechanical ventilation, if provided, in stages before measured pollution reaches the limiting levels for any of above gases. Tunnel closure procedures shall be implemented if pollution levels appear set to continue to rise above the recommended carbon monoxide EH40 levels (15 minute reference period values). Limit values for tunnels longer than 2500m shall be derived from first principles.

- A = tunnels up to 500m in length**
- B = tunnels 500m up to 1000m in length**
- C = tunnels 1000m up to 2500m in length.**

Table 5.2 Carbon Monoxide and Oxides of Nitrogen Limits for Road Users Within a Tunnel (based on HSE EH40 values)

Application	K - "Visibility Loss" at peak traffic (m ⁻¹)
Fluid traffic V _{max} = 60 - 80 km/hr V _{max} = >80 - 100 km/hr	<= 0.007 <= 0.005
Congested traffic	<= 0.009
Tunnel to be closed	>= 0.012
Maintenance work, with tunnel traffic	<= 0.003

V = traffic speed
K = extinction coefficient.

Table 5.3 Visibility Limits (haze from vehicle fumes etc)

Age of vehicle	Percentage in national fleet (%)
1	12
2	12
3	11
4	10
5	10
6	9
7	8
8	7
9	6
10	5
11	4
12	3
13	2
14	1
15 and older	1

Table 5.4 Indicative Age Breakdown for National Vehicle Fleet

Traffic Condition	Average Mass (tonnes)
City tunnel with a large percentage of light weight trucks, delivery vans and buses	10 - 15
Highway tunnels on typical national highway networks	15 - 25
Tunnels on major transport networks with a high percentage of fully loaded trucks	25 - 35

Table 5.5 Average Weight of Goods Vehicles

Exposure Period	Mixed Pollutant Concentrations of
	CO, NO and NO ₂ gases in ppm
Long Term Exposure Limit (8 hour time weighted average)	$CO/30 + NO/25 + NO_2/3 < 1.0$
Short Term Exposure Limit (15 minute reference period)	$CO/200 + NO/35 + NO_2/5 < 1.0$

Notes: See text for estimating concentrations of NO (nitric oxide) or NO₂ (nitrogen dioxide) where only NO_x combined gas or NO is monitored. CO is carbon monoxide for which proposed EH40 values for 1999 have been included. Parts per million is abbreviated to ppm. For intermediate exposure periods apply as per EH40. For the current state of knowledge, combining the limits of the three gases is believed to be conservative.

**Table 5.6 Mixed Exposure: Occupational Exposure Limits
(For Maintenance Staff, Police etc Working Within Road Tunnels)**

Pollutant	8 Hour Time Weighted Average, Limit (ppm)	15 Minute Reference Period, Limit (ppm)
CO	30	200
NO	25	35
NO ₂	3	5

Note: For reference only, as Table 5.6 limits govern.

**Table 5.7 Individual Pollutant: Occupational Exposure Limits
(For Maintenance Staff, Police etc)**

EH40 Occupational Exposure Standard	Maximum concentration by mass
Long term exposure limit (8 hour time weighted average)	3.5 mg/m ³
Short term exposure limit (15min reference period)	7 mg/m ³

Note: Provisional limit values have been given based on carbon black limits pending HSE recommendations for Engine Exhaust Emissions currently under review on the ACTS/WATCH programme. Proposed particulate matter PM₁₀ limits to Air Quality Framework Directive 96/2/EEC is to achieve a 50 µg/m³, 24 hour limit for the open air by year 2005.

Table 5.8 Diesel Smoke Particulates (Carbon Black): Total Inhalable Dust Occupational Exposure Limits (For Maintenance Staff, Police etc)

Fire Size (MW)	Distance Upstream of Fire (m)	Distance Downstream of Fire (m)
5	-	-
20	10	40
50	20	80
100	30	120

Table 5.9 Distances Over Which Jet Fans may be Considered as Destroyed During Fire

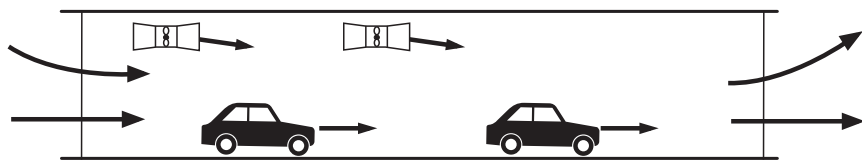

Basic Longitudinal Ventilation
(1 way or 2 way traffic - short tunnel)

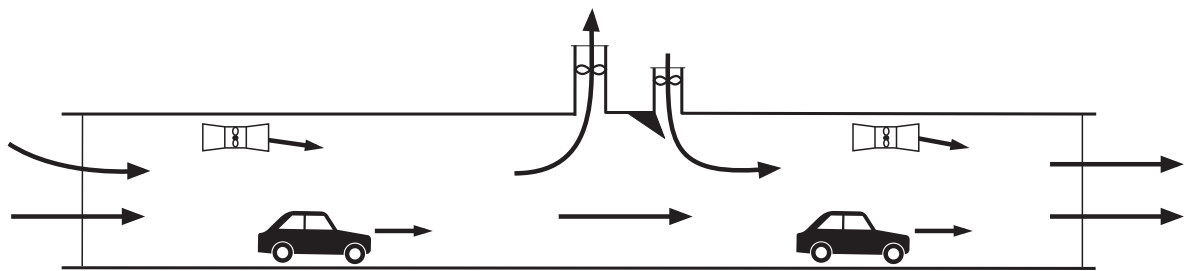

Longitudinal Ventilation with Air Exchange
(1 way or 2 way traffic - long tunnel)

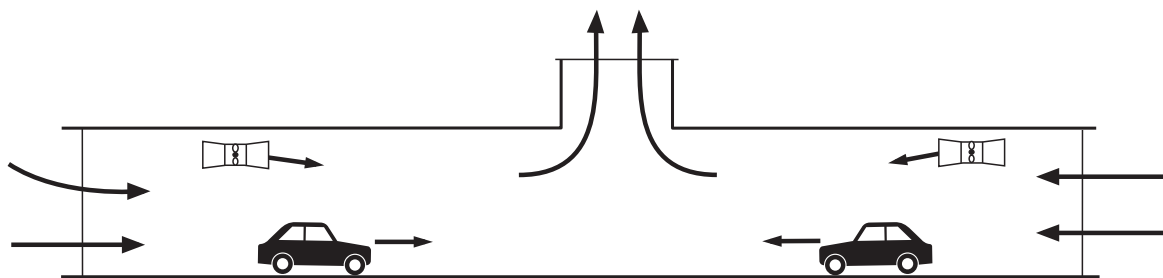

Longitudinal Ventilation with Central Exhaust Shaft
(Two way traffic - Long tunnel)

Figure 5.1 Examples of Longitudinal Ventilation

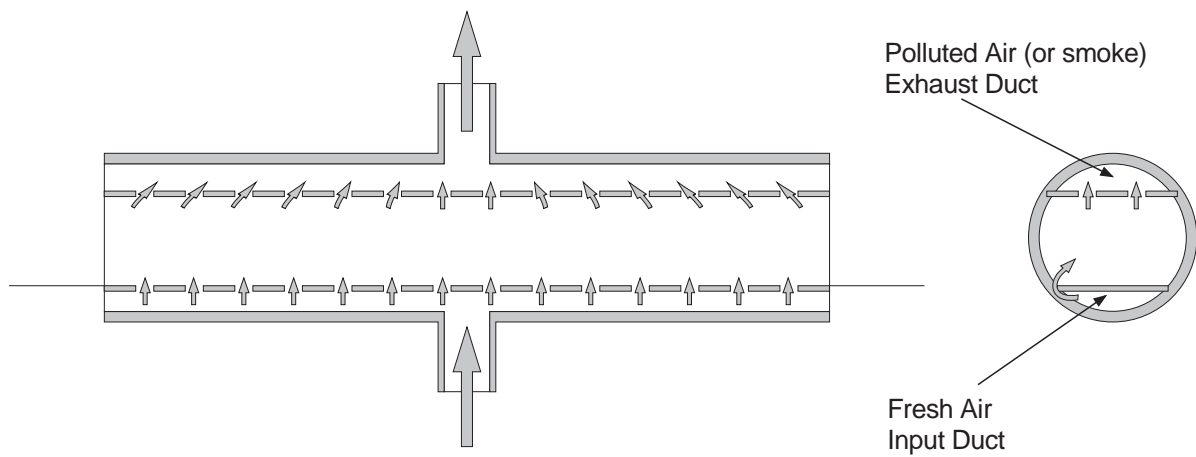

Figure 5.2 Full Transverse Ventilation

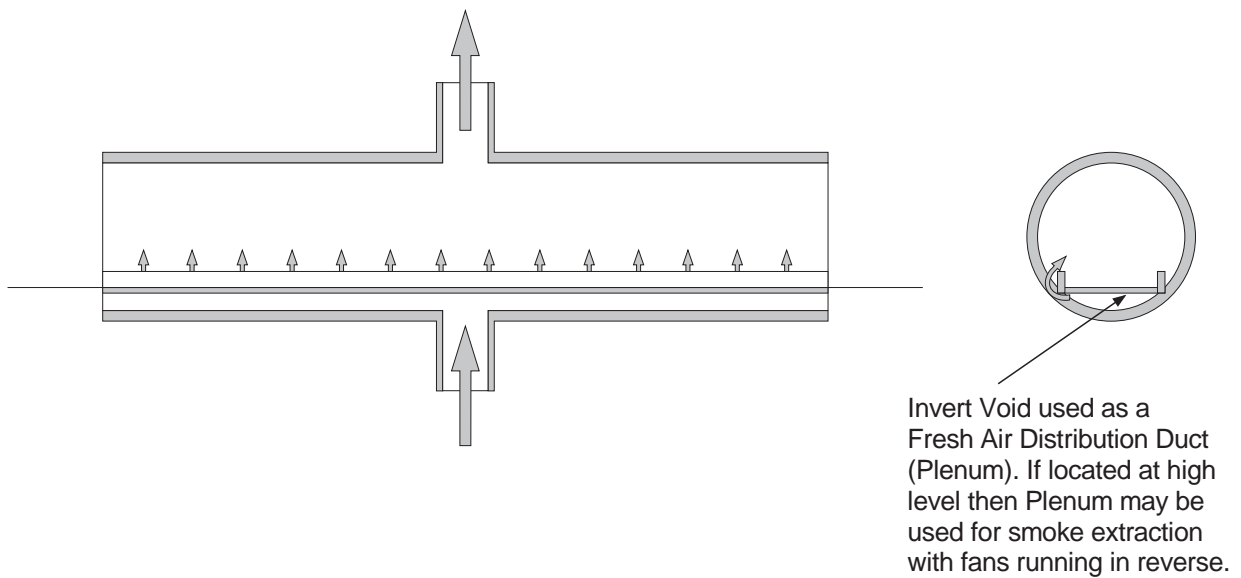
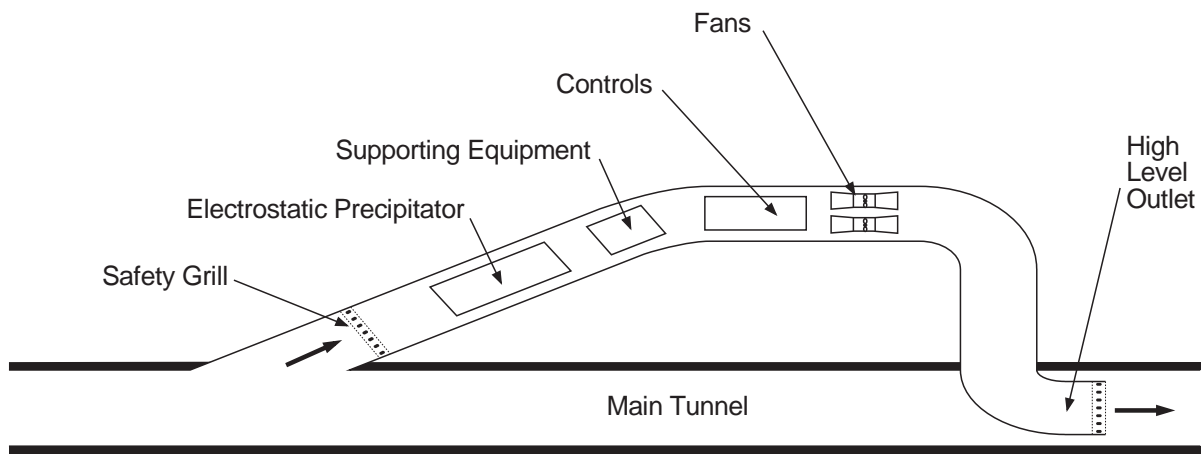
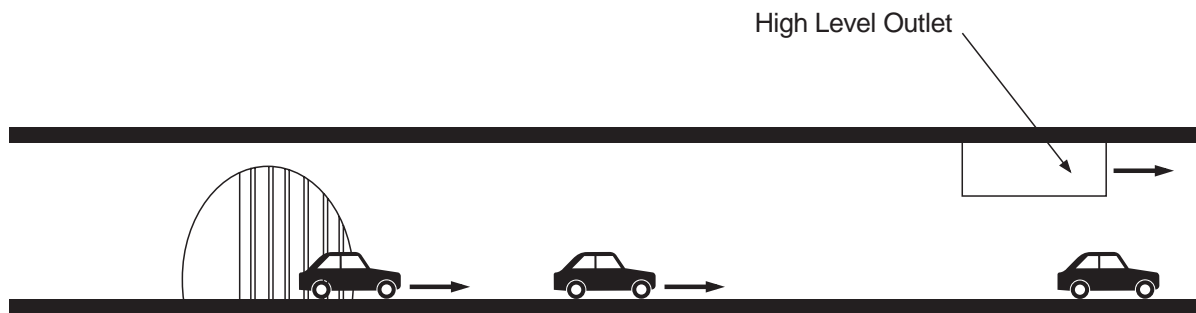

Figure 5.3 Semi-transverse Ventilation



Plan



Section

Figure 5.4 Example Electrostatic Precipitation Station Within a Tunnel

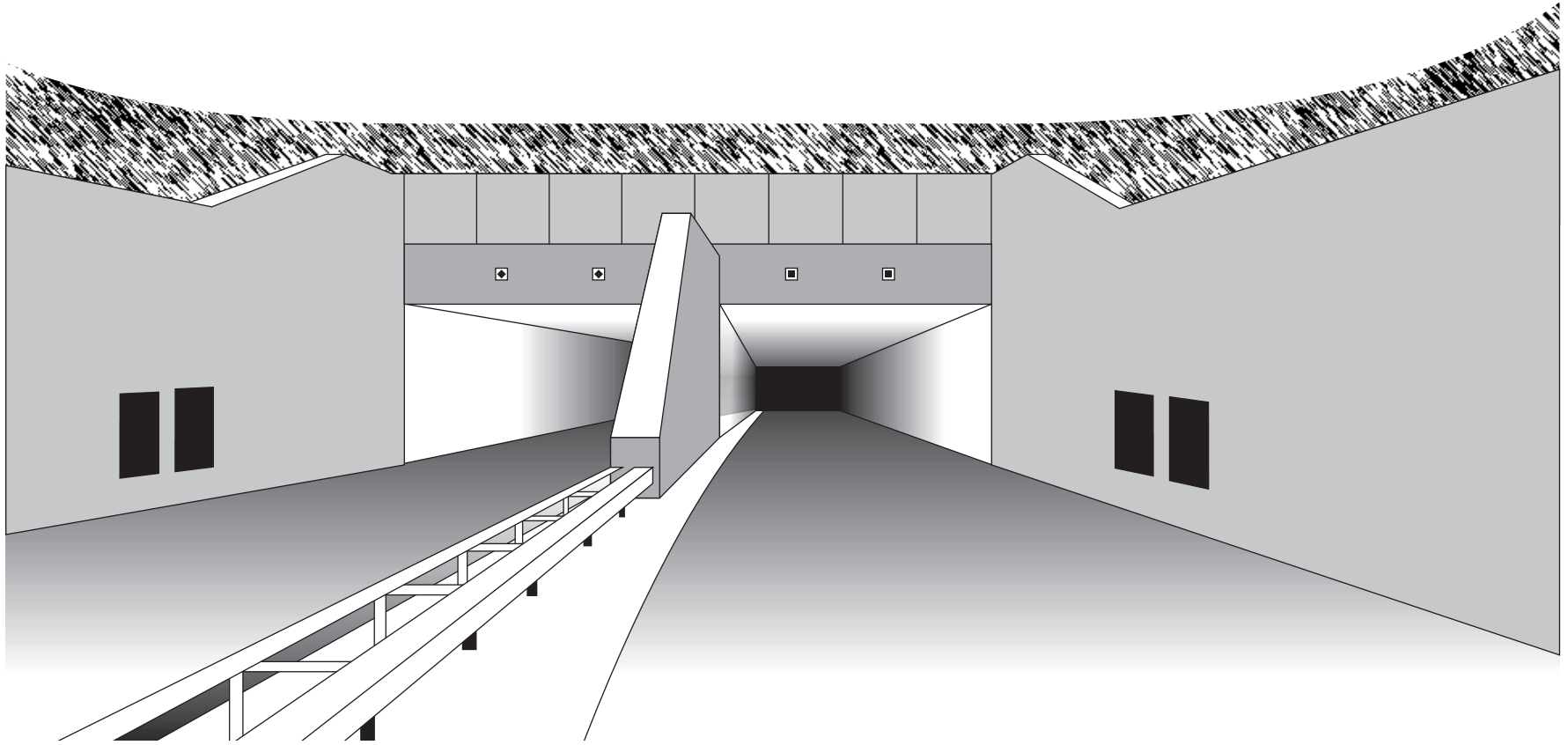

Figure 5.5

Anti-recirculation Wall

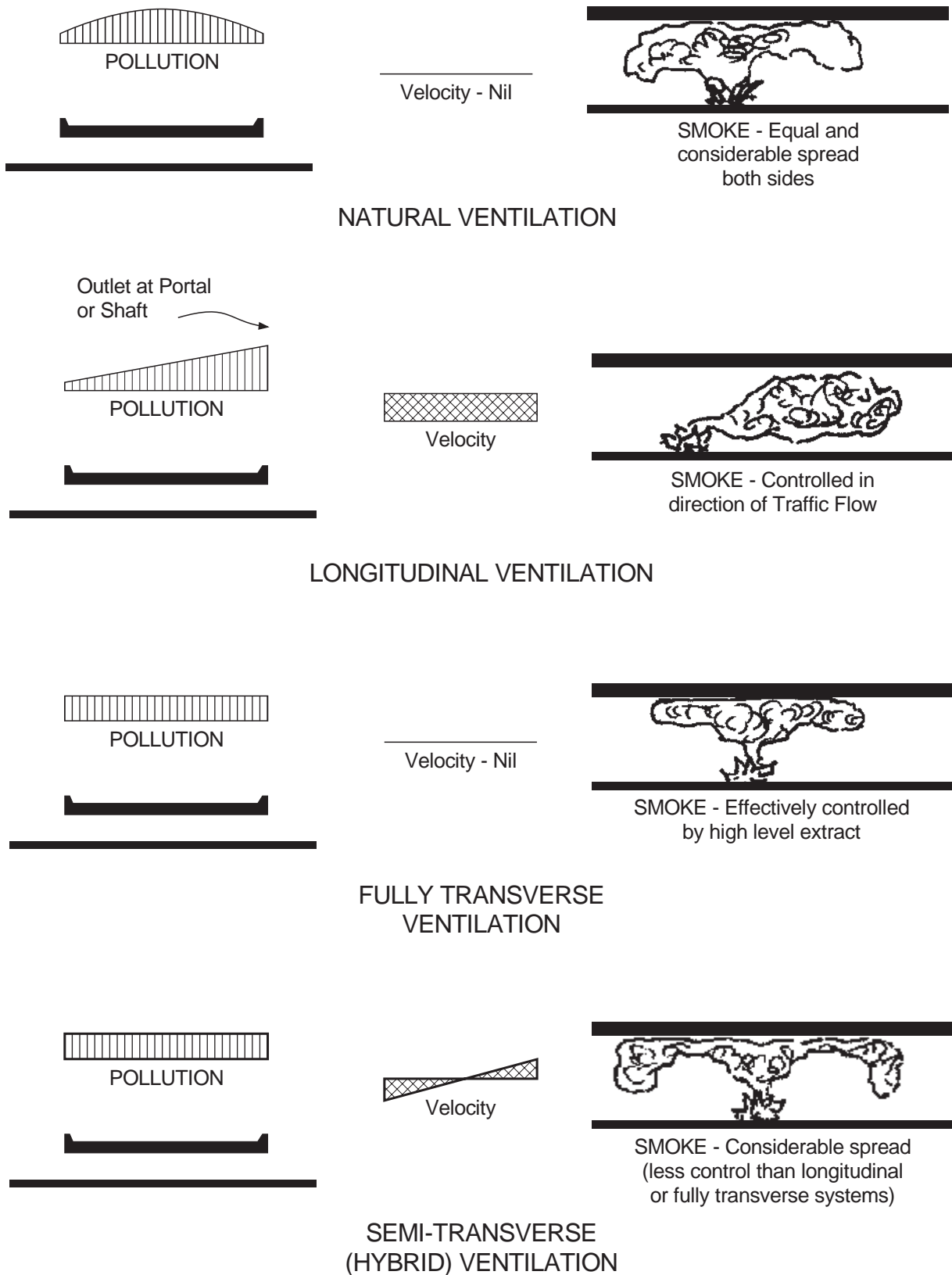

Figure 5.6 Tunnel Ventilation Systems and Fire

6. TUNNEL LIGHTING

General

6.1 A high standard of lighting is provided in road tunnels to enable users of the tunnel to see their way and to identify potential hazards quickly. Good lighting also helps to make a tunnel to appear less claustrophobic and daunting. See Chapter 9 for the lighting of signs.

6.2 This Chapter provides the background information and technical criteria that influence the planning, design, maintenance and operational aspects of tunnel lighting. Guidance is given on the options for carriageway and wall surface finishes, location of luminaires, choice of light source, together with factors relating to life cycle costs, energy saving considerations and the cleaning and maintenance regimes. The control of the threshold, transition and exit levels of lighting (see Figure 6.1) is directly related to continuous readings of external ambient conditions. A luminaire is the apparatus which distributes, filters or transforms the light given by a lamp and includes the necessary items to fix, protect and connect to electrical supply. The threshold zone is the first entrance section of a tunnel which is brightly lit so that drivers on the access zone (tunnel approach) can see obstructions when past the stopping sight distance to the portal. The transition zone is a further section which provides a gradual reduction in lighting to the levels of the interior zone. The exit zone is a section where the driver's eye readapts to the outside lighting levels and provides lighting for driver's rearward vision on exit. Direct illumination in the exit zone also increases the visibility of any smaller vehicles positioned in the shadow of larger vehicles in front.

6.3 On entering a tunnel from the brightness of daylight surroundings, it takes a short time for drivers' eyes to adapt to the relatively dimly lit tunnel interior. The distance travelled whilst this adaptation takes place is directly proportional to the speed of the vehicle. To ensure that vision is not impaired, lighting is reduced progressively in the threshold and transition zones (see Figure 6.1) of the tunnel to give a safe adaption from external to internal light levels. A similar provision is made at the exit to assist the reverse transition back into daylight. The exit zone is shorter than the entrance zone because drivers' eyes adapt from dark to light more quickly than from light to dark. Allowance needs to be made for tunnels of an east to west orientation, when the sun is low.

6.4 Unlike lighting for open roads, tunnel lighting is at its peak during bright daylight, reducing to a minimum at night (BS5489: Part 7). Automatic controls shall be provided to regulate the tunnel lighting to suit external conditions and to minimise energy consumption by ensuring that no more lighting is used than is actually required.

6.5 Visual flicker (impression of fluctuating luminance or colour) of between approximately 2.5 and 15 Hz, caused by spacing luminaires at certain intervals, may lead to discomfort or distress for drivers passing through the tunnel. Luminance is the amount of light emitted in a given direction from a unit area of surface.

6.6 The Standard to be used for tunnel lighting design is BS5489 Pt. 7 (Code of Practice for the Lighting of Tunnels and Underpasses). The Standard contains a full explanation of the parameters and procedures involved, worked examples, definitions and terminology. Counterbeam lighting has had mixed success in use overseas and some countries have had to combine such lighting with symmetrical lighting for safety reasons.

6.7 Tunnel lighting shall be designed for traffic, moving at design speed, to approach, enter, travel through and exit a road tunnel at a safety level equal to that on adjacent stretches of open road. The design shall take account of day and night time conditions of driving, and operation and maintenance requirements.

6.8 Decisions relating to tunnel length, location, orientation, cross sectional profile, approach road conditions, designated design speed, surface finishes and the structure and form of the portals are important factors that affect the detailed design and cost of tunnel lighting. Early consideration shall be given to these factors and tunnel operation and maintenance procedures. The quality of the reflective interior wall or lining finishes together with the lighting design strongly influence the driver's sense of well being about tunnel driving safety.

6.9 Tunnel lighting is designed to ensure that the background lighting to obstacles on the carriageway is bright enough to enable obstacles to be recognised in silhouette, at an appropriate sight stopping distance. This depends on the levels of lighting and on the reflective properties of the background. For tunnels, the

background to be illuminated is the road surface and the lower sections of tunnel walls.

6.10 The measure of light reflected towards the observer, from carriageway and walls, is called luminance. The ease of detecting an obstacle is very much influenced by the contrast in luminances between the obstacle and the background, which are a function of the reflectance of their surface finishes. Reflectance is the ratio of radiated to incident light.

6.11 In terms of lighting provision, the main demand is for the change from daylight to interior tunnel lighting conditions and the reverse on exit. The zones (access, threshold, transition, interior and exit) of luminance reduction and increase are illustrated in Figure 6.1. The penetration of natural daylight into the tunnel at the entrance and exit portals generally means that artificial lighting is not required for the first 5 metres inside each portal.

6.12 Lighting in the threshold and transition zones is designed to provide a staged reduction of the level of luminance from that in the access zone and portal areas. The calculated lengths of these zones depends on sight stopping distances for the design traffic speed; the upper limit of external luminance determined for the particular site; the overall reduction required to match interior zone levels of lighting. Because a driver's eyes adapt more rapidly from dark to bright, reinforced exit zone lighting requires a shorter transition between the tunnel interior and external conditions (one way traffic). For two way, contraflow operation, in a normally one way tunnel, speed restrictions may need to be imposed, sufficient to allow time for oncoming drivers' eyes to adapt at the rate allowed by the exit zone lighting.

Choice of Light Source

6.13 Luminaires are normally aligned with their long axis parallel to the road. Their light is predominantly directed transversely across the tunnel giving a longitudinally symmetrical light distribution. Counterbeam (asymmetric longitudinal) lighting directed towards the oncoming traffic is not recommended for traffic safety reasons, where contrast has not been sufficient to distinguish obstacles reliably.

6.14 A wide variety of light sources are available. Choice for a particular application and performance shall offer the minimum whole life cost, taking into account energy consumption, lamp replacement intervals and costs of luminaires and lamps. Table 6.1 provides a guide to typical characteristics of lamps commonly

considered for tunnel lighting installations, together with induction and sulphur lamps etc which are being developed. Fluorescent lamps are of the discharge type where fluorescent material is excited by ultraviolet radiation. They are most suitable for the interior zone and night time lighting. Lengths of 1.5m to 1.8m are preferred and lamps and starting gear shall be suitable for starting in temperatures below 0°C. Restrike times and flicker are minimal, light distribution is even with good colour control and lamps are dimmable for energy saving. Sodium vapour lamps are of high pressure (10,000Pa) SON or low pressure (5Pa) SOX partial vapour types. They are suitable for the higher lighting level zones. No more than 3 wattage types shall be used. Louvres shall be used in the luminaires of SON to reduce glare. Dimming is possible with special equipment. Flicker and restrike time shall be considered for any use of SOX or SON in interior zones.

6.15 The following characteristics shall be considered when determining the most appropriate types of lamp:

- i. Lamp Circuit Luminous Efficacy: A measure of the energy efficiency of a lamp, presented in terms of lumens of light output per watt of power consumed by the lamp and its associated control gear.
- ii. Lumen Maintenance: The average number of operating hours from new when light output will have dropped to 80% of the initial value.
- iii. Lamp Survival: The number of operating hours from new when 20% of lamps in an installation will have failed.
- iv. Restrike time: The time taken to restore full light output after restoration from interruption of the normal electricity supply.
- v. Colour Rendering Index: A measure of the ease with which different colours can be distinguished under the light from the lamp. This is particularly important if compatibility with colour CCTV is required.
- vi. Shape: Linear sources emit light over the full length of the lamp and therefore differ in beam appearance and apparent brightness from more concentrated point sources.
- vii. Dimmable: Dimmable luminaires offer greater flexibility of control for energy saving but with higher capital and possibly higher maintenance costs.

6.16 The design of luminaires shall be related to tunnel profile, systems of support, ease of access and vulnerability from traffic. Luminaires shall be of robust construction, sealed to IP65 requirements to prevent the ingress of moisture, and adequately protected against the harsh conditions of the tunnel environment ie the combined corrosive effects of vehicle pollution, dust, chemicals used in tunnel cleansing, and road salts thrown up by traffic turbulence. See Chapters 2 and 11.

Spacing and Location of Luminaires

6.17 To prevent light flicker, Table 6.2 gives the intervals between light sources that shall be avoided in the interior zone. BS5489 provides details of relaxations possible for tunnels less than 1000 metres long or where the bright areas of luminaires are larger than the dark intervals between them.

6.18 Luminaires shall be located so as to permit simple and easy access for cleaning, re-lamping and complete replacement when required. The selected location has a significant impact on the light distribution within the tunnel and should be determined at an early stage.

6.19 *Centrally Mounted Luminaires:* For many two lane tunnel interior zones a single central line of fluorescent luminaires, mounted continuously end to end, can provide the required illuminance. This is the most efficient means of lighting the carriageway evenly. However, access to luminaires is likely to require complete closure of the tunnel bore since both lanes will be obstructed. Additional lighting required to reinforce the entrance and exit zones is achieved by the addition of further adjacent lines of luminaires.

6.20 *Cornice Mounted Luminaires:* Mounting luminaires on either side of the carriageway offers the possibility of maintenance access, if safety considerations permit, to one row of lighting whilst, permitting traffic flow in the remaining lanes. However, smaller tunnels may not require two continuous lines of luminaires. If one line only is provided, the far traffic lanes will receive a reduced level of illumination. The latter problem may be overcome with asymmetrical reflector shapes.

Light at Tunnel Portals

6.21 Apart from the attention that will need to be given to the aesthetic appearance of portal designs, the orientation, general layout and surface finishes will have

a significant effect on levels of reinforced lighting installed at tunnel entrances.

6.22 The location and orientation of tunnel portals will generally be decided by optimising tunnel length and gradients in terms of construction and operating costs. The portal areas shall allow and encourage a safe and smooth transition from the open road to the tunnel.

6.23 Although commonly used as a means of reducing energy consumption of threshold zone lighting, the use of daylight louvre or screen structures over the tunnel entrance to reduce the amount of direct sunlight reaching the road surface and walls, has the following disadvantages:

- i. The degree by which the screens exclude natural daylight will vary according to the position of the sun and the amount of diffusion of sunlight by cloud. Actual performance of the screens is therefore very difficult to predict.
- ii. The presence of screens can promote icing of the road surface beneath from water drips, icicles, and areas in shadow.
- iii. Structures requiring maintenance are introduced at critical points of the tunnel.
- iv. Structure is open to vandalism.

6.24 If screens are considered, the following aspects shall be carefully studied in addition to the above:

- i. The possible effect on drivers of any flicker induced by passing through alternating bands of bright sunlight and shade
- ii. The frequency of cleaning required to maintain performance
- iii. The possible effects of strong winds or the accumulation of snow and ice
- iv. The effect on dispersal of polluted air from the tunnel.

6.25 The effect on levels of light pollution from the tunnel portals shall be considered.

Whole Life Costs

6.26 The overall objective is to achieve the optimum design that will keep the costs of lighting as low as possible throughout the lifetime of the installation. Account shall be taken of the initial capital installation

costs, the maintenance factor (anticipated permitted deterioration) that will determine the nature of the overall cleaning and maintenance commitment, together with the energy and maintenance costs over a 20 year period which is deemed to be the design life of the luminaire. Switching stages are the predetermined number of levels of lighting. Six stages have been commonly used but research in France has indicated that three, or even two, stages may be more economic when installation costs are also considered. When calculating energy costs it is important to identify the hours run for each stage of lighting rather than adopt average values.

Colour and Surface Reflectance

6.27 On the immediate approaches to the tunnel, darker coloured, less light reflecting portals, retaining walls, and asphalt road surfaces, trees and extended facades assist the adaptation process, by reducing surface luminance and the effects of low sun angle, and provide a relative reduction in the length of the threshold zone.

6.28 The wall and road surfaces within the tunnel shall have high reflectance of diffused light. This leads to significant power savings, will reduce the number of luminaires required in the transition zone and provide a high luminance background to silhouette any obstructions (see Fig 6.2). The effect on lighting reflectance shall be taken into account with any proposal to change the road surface from that originally designed for.

6.29 Road surface reflectances vary according to materials of construction used. An asphalt surface has a reflective value of 0.15, and a plain concrete surface up to 0.3. Reflectivity depends on colour and texture, eg a smooth or coarse surface finish. The dependence of reflectivity on the composition of the road surface is discussed in CIE66 and the method of calculation of the effect on luminance in CIE 30.2. Some countries introduce ballotini strips into asphalt surfacing for low lighting level tunnels.

6.30 Choice of wall finish may depend on the form of tunnel construction dictated by civil engineering considerations. It can range from plain concrete, facing blocks with an applied surface coating to purpose made secondary linings. Wall reflectance shall be not less than 0.6 and the height of the part of the wall having high luminance to obtain maximum silhouette shall be at least 4 metres. The light distribution cut-off angle shall be arranged to coincide with the 4 metre line. See Figure 6.3. Cut-off is the technique to conceal lamps from direct view, to reduce glare.

6.31 High gloss textured finishes shall be avoided because of the specular (mirror like reflection without diffusion) and glare problems from daylight, vehicle stop lamps and traffic signs. Specular reflection from vehicle headlights is particularly disadvantageous when two way traffic flow is in operation. See Figure 6.4.

6.32 Colour schemes shall be:

- i. Light colours from road surface level up to the 4 metre line.
- ii. Darker colours above the 4 metre line including the roof space.

6.33 The dark colour area above the 4 metre line serves three functions:

- i. In the case of a circular/horseshoe shaped tunnel it avoids the claustrophobic reflective tube effect, which can be disturbing to drivers in long tunnels, and replaces it with a tunnel of visual rectangular appearance, giving apparent width to the tunnel.
- ii. It obscures the hardware installed above the luminaires and improves the aesthetic appearance.
- iii. Provides a visual limit for the wall cleaning machine and hides a soiled appearance where the surface is not cleaned.

6.34 High wall reflectivity contributes to the luminaire light distribution onto the road surface.

Cleaning, Maintenance and Lamp Replacement

6.35 The continued reflectivity of the tunnel surfaces depends on their state of cleanliness. Tunnels shall be washed periodically to maintain the wall reflectivity to the level adopted in the design. The period between cleaning operations varies according to tunnel usage, season, geographical location of the tunnel and the actual design of the tunnel. An initial cleaning frequency shall be set which can then be varied accordance to actual experience and cost-benefit case.

6.36 The cost of maintaining and cleaning the tunnel walls and luminaires should be set against the additional cost of lighting the tunnel to the required standard without cleaning. The state of the walls and internal luminance shall be monitored periodically and the cleaning interval varied accordingly to achieve the optimum cost benefit. Once established, cleaning

routines and lamp replacement schedules shall be adhered to in order to maintain the minimum levels of illumination. The design maintenance factor shall be not less than 0.8. Apart from the deterioration component which can be corrected by cleaning, there is the long term permanent deterioration of luminaires and wall finishes. Site tests shall be carried out at not more than 3 year intervals to check that photometric performance is acceptable.

6.37 The means of access to the interior of luminaires for replacement of lamps and control gear will have an impact on maintenance costs. End-opening luminaires are easier to seal against the ingress of moisture but require complex and expensive mounting brackets and access is generally more complicated. Front opening luminaires offer improved access with simpler mounting arrangements are preferred but care needs to be taken to ensure that the considerably longer gaskets provide a reliable seal at all times.

Provision for Special Operating Conditions

6.38 The lighting system may need to be designed for the tunnel operating under a number of special conditions. For example, in the case of a twin bore tunnel, one bore could be completed and opened to two way traffic for a considerable time before the second bore is completed. Even when completed, maintenance could require that one bore was closed to traffic and the second bore operated two way. Maintenance work involving two-way working will often be carried out at night, and so not require any modification of the lighting system. However, when maintenance is carried out in the daytime, contraflow lighting arrangements shall be considered.

6.39 Under emergency conditions, two way traffic may become necessary in a tunnel designed for one way flows, in which case entry speeds would have to be restricted at both portals since the normal exit lighting would be inadequate for contraflow entrance operation at normal operating speeds.

6.40 If two way tunnel operation is required during daylight hours, an assessment shall be made by the TOA regarding a safe working speed, and sufficient speed warnings and restrictions shall be in place to ensure the safe operation of the tunnel. The lighting must be suitable for the clear visibility of the sign and signal system needed to control such special working.

Monitoring and Control

6.41 The monitoring and control of tunnel lighting is based on measuring external lighting values, based on either illuminance or luminance (ie light incident on surfaces). The luminance method is more precise for energy cost control and should be adopted. See also Chapter 10.

6.42 The luminance method adopts the use of a pole mounted photocells or photometer located at the approximate adaptation point outside the tunnel portal. The adaptation point is where the driver's eye starts to adapt to the relative darkness of the approaching tunnel. The photometer is aimed towards the centre of the tunnel portal to a point 1.5m up from the road surface, and records the average luminance level from within a 20° cone. The value is similar to the veiling luminance impinging on a driver's eye approaching the tunnel ie taking into account the reflective factors of the various surfaces surrounding the tunnel portal and the sun's location etc. CCTV luminance cameras could be used instead of photometers.

6.43 Paired photometers are normally used, both facing the same portal, the average value from each is used to determine the automatically operated switching stages. On failure of one photometer an alarm would be raised and the other photometer would continue the switching sequences. Periodic calibration or self calibration of the units is required.

6.44 Control of the switching stages is by a computer based system to switch various lamps on or off at prescribed daylight levels. Frequent switching of stages shall be prevented and cooling times for certain types of luminaire provided by computer control. A time delay or moving average system is incorporated so that any short lived changes such as caused by cloud movements are discounted. For economy, dimming controls shall be considered so that lighting levels between fixed stages can be achieved. Time switches are also used to augment the photometers. Light switching and control gear shall be designed to prevent flickering by locking out luminaires which do not achieve or sustain continuous discharge.

6.45 Photometers or light meters can also be used inside the tunnel to compare lighting levels with those outside. By matching the two levels via a computer and switching the lighting accordingly, sharp contrasts in brightness are avoided. See also Chapter 10.

Incoming Power Supply

6.46 See Chapter 11.

Emergency Lighting

6.47 See Chapter 11.

Lighting Distribution and Cabling

6.48 See Chapter 11.

Lamp Type	Efficacy	Lumen Maintenance	Survival	Restrike Time	Colour Rendering Index	Shape	Dimmable
	Lumens/circuit watts	Hours to 80% output	Hours to 20% failed	Minutes	Ra		
Fluorescent (MCF)	75 - 80	16,000	9,000(1)	Instant	50 - 85	Linear	Yes
Mercury (MBF)	45 - 50	6,000	16,000	4	50 - 60	Point	No
Low Pressure Sodium (SOX)	130 - 150	14,000	8,000	10	Monochromatic: no colour discrimination	Linear	No
High Pressure Sodium (SON)	90 - 130	24,000	16,000	1 (2)	25	Point(4)	Limited (3)
Deluxe High Pressure Sodium (SON-DL)	90 - 130	9,000	8,000	1	60	Point(4)	Limited (3)

Table 6.1 Typical Characteristics Of Light Sources

- Notes:** (1) The life of fluorescent lamps may be extended if high frequency electronic control gear is used. However, such control gear is more expensive than conventional ballasts and may have a shorter service life.
- (2) The figure given is for conventional lamps and control gear. Lamps with twin arc tubes offer the possibility of near instant re-strike, but at increased cost.
- (3) Devices which offer a limited degree of dimming are available but are largely unproven.
- (4) A linear effect can be attained by the use of tubular guide lights.

Maximum Traffic Speed	km/h	120	100	85	70	60
Prohibited Spacings	metres	2.0 - 13.0	1.8 - 10.5	1.6 - 10.0	1.3 - 8.5	1.2 - 8.0

Table 6.2 Luminaire Spacings Which May Cause Perceived Flicker

Note: (1) The term spacing is taken to mean the distance between ends of adjacent lamps, in the longitudinal direction.

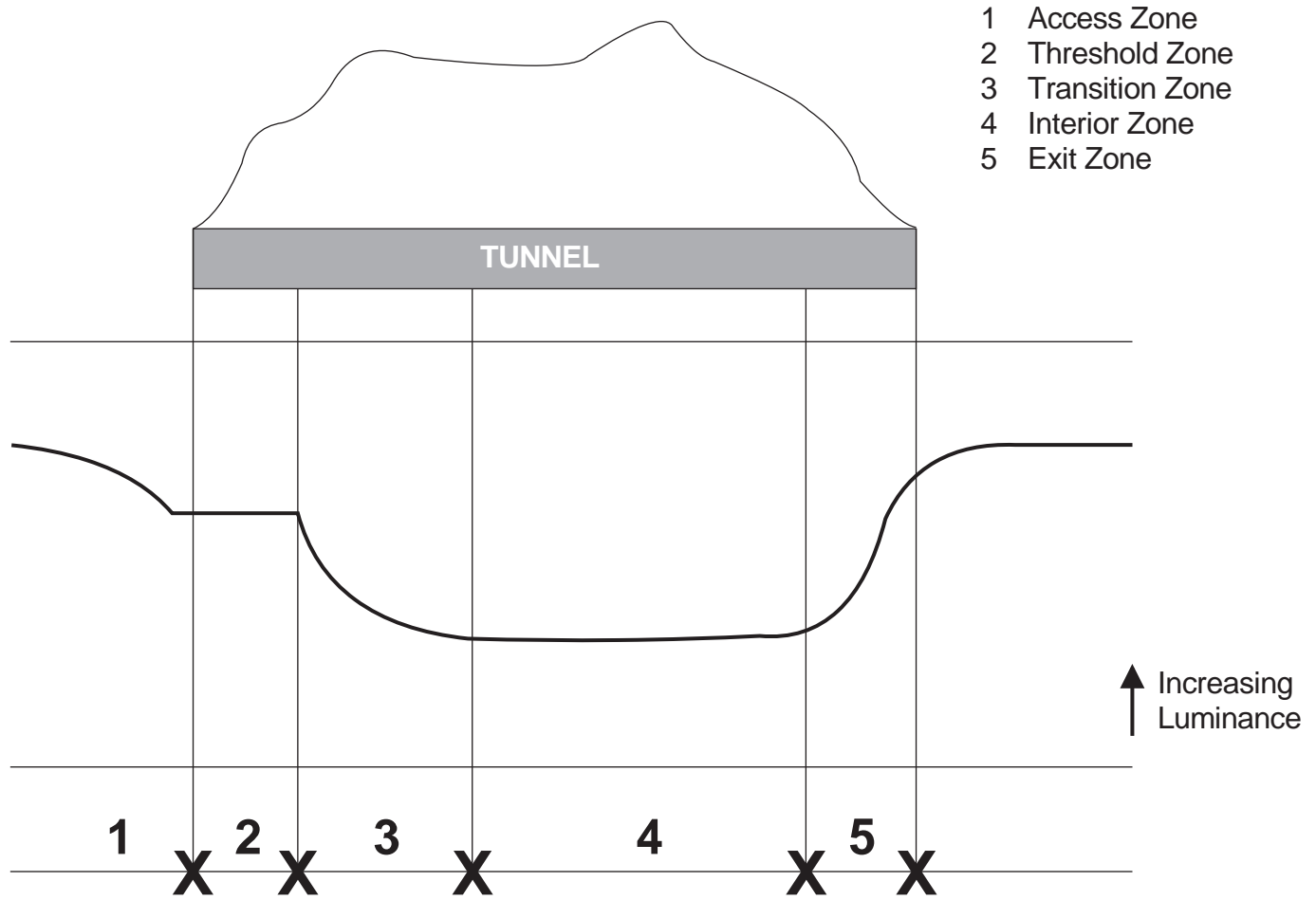

Figure 6.1

Luminance Reduction Curve Example



Figure 6.2 Example of Light Reflected from
Wall and Road Surfaces

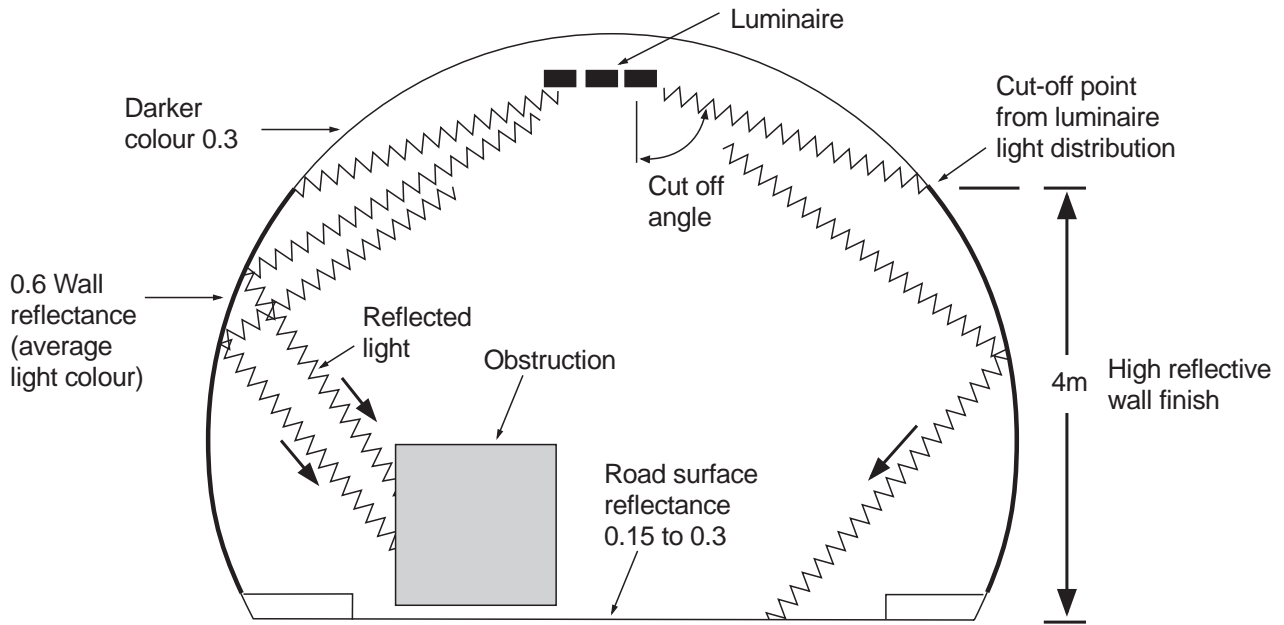

Figure 6.3 Light Distribution



Figure 6.4

**Undesirable Reflections from
Specular Surfaces**

7. DRAINAGE

General

7.1 This Chapter describes the provision to be made for drainage arrangements in tunnels. It provides background information and technical criteria relating to the collection and discharge of inflows, the siting and sizing of sumps, separators and pumping stations, including related operational and safety aspects. The procedures to ensure compliance with effluent standards and the requirements of the local water authority are described.

7.2 Unless the vertical alignment of the road through a tunnel is a crest curve (more achievable in mountain tunnels), it is normally necessary for a road tunnel to be provided with drainage sumps and pumping equipment to collect water from the road surface and discharge it safely. Where approach roads run downhill towards one or both portals it is normal to provide sumps to intercept storm water flowing down the approach roads and to prevent it from entering the tunnel. For such cases the catchment areas can be large and consequently portal sumps need to have a generous capacity.

7.3 In addition, where there is low point within the tunnel, an additional sump is provided to collect any water from the road surface inside the tunnel. Because most storm water will be collected at the portals, this sump is normally sized to receive water from predicted ground water seepage, tunnel washing and the use of fire hydrants, as well as possible spillages from vehicles. In colder areas, subject to heavy snowfall, allowance shall be made for meltwater from snow and ice brought into a relatively warm tunnel by vehicles.

7.4 To cater for the wide range of possible inflow rates, sumps are provided with automatic controls which will regulate the number of discharge pumps operating according to the water level in the sump. The rate of pumping water out of a sump does not necessarily need to be the same as the rate of inflow provided that the sump has adequate storage capacity, and the sump design needs to be coordinated with that of the pumping equipment to achieve an optimum solution.

7.5 Because of the risk of spillages of petrol and oil, which in quantity could give rise to an explosive atmosphere in a sump and a major safety risk, sumps are equipped with ventilation and sensors which will detect a build-up of common hydrocarbons and will initiate

automatic protective measures to prevent an explosive atmosphere developing. These measures include flooding the sump with foam to prevent ignition, and shutting down pumps and sump ventilation fans to confine the hazard until it can be dealt with, and purging electrical machinery and switchgear rooms with eg carbon dioxide.

7.6 The design of an appropriate system of drainage to channel calculated inflows of water via road gullies and longitudinal drainage in to one or more sumps, will depend on the length, depth, structure and form of tunnels in relation to the considerations described in this Chapter..

7.7 The relevant requirements and recommendations of HA71 (DMRB 4.2.1) and HD33 (DMRB 4.2.3) shall be taken into account in the design of drainage systems.

Inflows

7.8 The calculation of expected inflows involves a detailed investigation of the nature and extent of:

- i. Ground water and the drainage of the tunnel structure
- ii. Rainfall
- iii. Tunnel wall washing
- iv. Fire fighting and wash down following spillages of dangerous goods within the tunnel.

Drainage Systems

7.9 A tunnel drainage system can be an integral part of a local road drainage system, or be designed as a self contained facility. It collects both ground water and surface water which drains from the tunnel roadways via road gullies and longitudinal drains and discharges into one or more main sumps. An impounding sump to contain road tanker spillages, and tunnel wash down water, which is likely to be heavily polluted must also be provided. A typical pumped drainage system arrangement is shown in Figure 7.1.

7.10 Pump stations and sumps are normally sited at the lowest point of a sag curve in the tunnel, and near

the portals. Control rooms or other buildings should not be located near sumps, due to the risk of explosion. Where there is no alternative, full safety precautions must be incorporated into the design of such buildings.

7.11 Pump stations, sumps and separators shall be sited where they have a minimum effect on the operation of the tunnel, particularly where regular access for their maintenance is required. Depending on design constraints, the sumps should be outside of the tunnel rather than under the tunnel carriageway.

7.12 A pumped system delivers drainage water through single or twin rising mains, passing along the tunnels below the road deck or by an external route, to discharge into a surface water sewer, or water course (if permitted).

7.13 The pumping installation shall be of the wet-well or dry-well type. For the former, the pumps are immersed in the water of the collecting sump, for the latter, the pump is mounted in a dry chamber, alongside the collecting sump or above it.

7.14 Dry-well installations are more usual when the pumps are large, mainly to enable maintenance operations to be carried out without removing the complete pump.

7.15 The sizing of sumps and separators is largely an iterative process in conjunction with the pump capacity and maximum inflow rate. Constraints on available power, size of pumping main, allowable discharge rate and the size of sump that can be accommodated all contribute to deciding the final sump volume and pump capacity. The working volume for the sump would be between high and low level limits with allowance for surge and residual water cover where submersible pumps are used.

7.16 Care shall be taken to size pumps appropriately for the volume of water to be discharged. Large pumps which only operate for short periods can increase the cost of energy supply disproportionately because of their increased starting and running current demands.

7.17 As a general rule, the number of pump starts per hour shall not exceed 12 and this shall be taken into account when determining the size of pumps/sumps and control levels.

7.18 Transverse interceptor drains shall not be used to remove storm water as they silt and can break up under heavy traffic. Provision shall be made for adequate crossfalls in conjunction with gullies at regular intervals

to remove the water and avoid ponding on the approaches to a tunnel.

7.19 Tunnel structure drains often become blocked by eg calcium compounds leaching out of concrete, groundwater salts, silt and construction site debris. Oversize drainage pipes shall be provided to make allowance for such problems. It is essential therefore to flush the drains regularly and to provide inspection chambers every 50m for ease of inspection and rodding.

7.20 As far as possible, all manhole and inspection chamber covers, such as those for access to sumps, pump chambers, valve pits etc, shall be located away from the carriageway, in order that maintenance and repair operations can be carried out without the need for a lane or bore closure. Where this is not possible, covers shall be positioned outside of wheel tracks. There is great potential for disruption to tunnel operation in the event of access cover failure or coming loose, presenting a hazard to traffic which needs to be dealt with immediately.

7.21 Road gullies shall be of a pattern suitable for installation in the kerb. Inspection chambers shall be located in the verge for better access and to avoid damage by traffic. Design data for gully spacing is contained in TRRL (Transport Research Laboratory) Report LR 277 and TRRL Contractor Report CR2. Gullies shall be installed at not greater than 20 m intervals. The minimum gradient for cross-falls is given in Chapter 4.

Effluent Standards: Consultation with Authorities

7.22 The Local Water Authority shall be approached for agreement at an early stage in the design concerning any discharge to the local foul water sewer. Constraints concerning quality and quantity of tunnel discharge shall be agreed with the Local Water, Environmental and Public Health Authorities together with any requirements for a Trade Effluent Agreement.

7.23 Highway Authorities (in Scotland, Roads Authority) have a statutory right, subject to the requirements of the Local Water Authority for discharge to sewers, or the appropriate Environmental Protection Agency for discharges to rivers or similar stretches of open water.

7.24 It is an offence to discharge any Class A products (Petroleum Spirit) into a public sewer. All water authorities will insist on the separation, and separate disposal under special arrangements, of any petrol, oil or

grease that may be spilt in a tunnel, before the drainage water is discharged.

7.25 There may also be a requirement that discharge should cease if the salinity of the drainage water exceeds a certain figure or, if the acidity or alkalinity are outside a certain range. The precise restrictions will depend on the place of disposal agreed. Rivers are classified for cleanliness and the quality of discharges into rivers will be governed according to the river's classification.

Calculation of Anticipated Inflows

Ground Water

7.26 The quantity of ground water flowing into a tunnel is dependent on the ground conditions, the design and constructional quality of the tunnel structure. Some of the common factors are itemised below:

i. Tunnels Beneath the Water Table

Water inflow into a tunnel will depend upon the water proofing system used. With a full water proofing system an inflow of less than 1.0 litre/m²/day would be expected (where the area in m² is the total internal surface area) this corresponds to Class A or O in Table 2 of CIRIA Report 81: Tunnel Waterproofing (now withdrawn but Table 2 is often used for reference). Substantially larger inflows are experienced where tunnels incorporate specific measures to drain the ground water and lower the water table.

ii. Tunnels Above the Water Table

Tunnels in this category may experience only intermittent water inflow from rainfall seepage or from leaking or burst water pipes or sewers local to the tunnel.

Precipitation and Runoff

7.27 The maximum quantity of precipitation to be expected within a given rainfall catchment area can be obtained from records and hydrographs published by the Meteorological Office, classified according to various "storm return periods", usually 20 year, 50 year and 100 year storms. The maximum quantity of water to be stored is usually assessed, by integrating the area under the hydrograph, for a storm and runoff of 60 minutes.

7.28 The amount of storm water that enters the tunnel and its approaches, and has to be removed, will depend on the position and level of the tunnel in relation to the local topography and the sizes of the catchment areas.

7.29 An estimate is to be made of the impervious areas external to the tunnel which will drain towards it.

7.30 A method of calculating run off is recommended in Road Note 35 using the Wallingford Procedure: Volume 4: Modified Rational Method.

Wall Washing

7.31 The quantity of water from wall washing operations is dependent on the techniques employed. For purposes of calculation, a water use rate of 5 l/m² of wall area can be used over the period of cleaning.

Hydrant Water

7.32 Most tunnels are equipped with hydrants at frequent intervals, fed from wet fire mains running along their lengths. For such cases, a reasonable allowance would be that two hydrants are used by the Fire Brigade for wash down purposes giving a flow of approx 66 l/s.

7.33 In cases where a fire main could be vulnerable to damage from a traffic incident, the duty of the pumping system may need to include for the potential outflow from a broken pipe based on its pressure/flow calculations.

Sumps, Separators and Pumping Stations

7.34 Each sump, or interconnected series of sumps, shall be of sufficient capacity to contain not only an adequate volume of drainage water, but also to retain any spillage of flammable or other hazardous liquids, up to the maximum capacity of one road tanker load.

7.35 Adequate water storage capacity must be provided to contain any inflow in excess of the maximum pumping rate. Where large sumps can be justified, they offer the opportunity to keep down the size of pumps.

7.36 Sump structural depths shall be calculated to allow sufficient space above the highest water level (ullage) for ample formation of a suppressant foam blanket and to accommodate a floating skimmer pump or suction head, if provided. The overall depth shall be sufficient for correct operation of level detection equipment.

7.37 The general arrangement of the sump shall be designed to minimise any turbulence around the pumping plant, arising from high inflow rates, and which may impair the performance of the pumps.

7.38 A forced ventilation system is required for any closed sumps, within the tunnel, in order to maintain a safe atmosphere for personnel working in the void; to dilute any potentially dangerous atmosphere, including that due to accidental spillage on the carriageway; to remove any fire extinguishing gases.

7.39 Sumps outside the tunnel shall be naturally ventilated.

7.40 With the possibility of flammable liquid flowing into the drainage system, a combustible gas detection system shall be provided. Sensing shall be arranged in two stages corresponding to low and high concentrations of hydrocarbon gases.

7.41 Design of sumps shall include precautions to minimise structural damage due to explosion, and its transmission where there is an adjacent interconnecting sump.

7.42 Interceptors/separators shall be of sufficient size to allow adequate separation of the pollutants, particularly where their operation depends upon reduced velocity across the unit.

7.43 Separators shall be designed for ease of cleaning and be ventilated to prevent the accumulation of dangerous gases. They shall be designed to minimise the risk of oil or other hydrocarbon substances, trapped in the separator, from being flushed through under high flow conditions.

7.44 The impounding sump shall be equipped with facilities for skimming oil and delivering it to road tankers, and removal of sludge, which otherwise could be discharged into foul sewers.

7.45 Sumps shall be classified as hazardous areas, generally Zone 2, except in exceptional circumstances, as defined by BS5345: Part 2. All pumps and electrical equipment located in these areas shall have the standard of protection appropriate to the zone, as specified in BS5345: Part 1.

Pumping Plant

7.46 The pumping duties required for a tunnel drainage system will be influenced by a number of factors including:

- i. The maximum expected inflow to the sump
- ii. The average normal expected inflow to the sump
- iii. Design constraints imposed by structural works

iv. Maximum discharge limitations

v. Discharge system parameters

vi. The size of the sump.

7.47 When the parameters are determined, pump system calculations, using suitable formulae or software, can be carried out. System/duty curves shall include for several options of pipe size, in order that minimum carrying velocity and acceptable power requirements can be considered. A typical graph is shown in Figure 7.2.

7.48 The maximum rate at which water can be pumped out may be determined by the Local Water Authority's Consent to Discharge, but this may be considerably greater than the expected rate under average conditions. Two or three pumps could be considered, which with all in operation, would be adequate to pump at the maximum rate, but individually would be sufficient to handle only the average rate.

7.49 Where a standby pump is provided, its duty is not normally included in the calculations. Pump operation shall be rostered to ensure that pumps share the duty and standby operations evenly.

7.50 Pumps are mostly of the single entry centrifugal type and shall be designed to pass water borne solid substances without choking. Pumps designed for sewage handling, passing round solids up to 100mm diameter, are well suited to tunnel application.

7.51 If the pump is installed above sump water level the pump must either be of the self-priming type or must be fitted with some auxiliary equipment designed to ensure that the pump will always be full of water before it is started.

7.52 The pumps may be of vertical or horizontal configuration, depending on design constraints. Vertical spindle submersible types are preferred as an additional room to house the pumps is not required, and they do not need ancillary equipment for priming.

7.53 Submersible type pumps have to be removed in total when inspection, repair or overhaul is required. It is usual to provide a permanently installed standby pump to maintain full functionality whilst one pump is removed. The pumps are frequently installed on vertical slide rails with automatic pipe couplings to facilitate removal and replacement. Electrical connectors, suitably rated for use in wet and hazardous atmospheres, shall be provided in an accessible position within the sump to facilitate electrical disconnection when the pump has to be removed.

7.54 Electrical driving motors may be mounted directly on the pumps or they may be mounted on a separate entablature at a higher level, driving the pump by means of extended shafts. The latter arrangement was preferred to ensure that the electric motor remained accessible for maintenance above the water level. Submersible type pump and motor units, can now be specified for installation in dry wells as cooling arrangements no longer require the unit to be submerged.

7.55 Plant shall be electrically bonded to ensure that metalwork is maintained at the same potential.

7.56 In addition to the main pumps and electrical motors the following are normally required:

- i. Motor control gear, cables and transformers. All these items shall be installed in a separate non-hazardous area away from the sump.
- ii. Water level sensing equipment to control the starting and stopping of pumps and to generate high level and flood alarms. Options include ultrasonic or radio frequency level detectors, float switches and fixed electrodes. In selecting level controls, consideration shall be given to the resolution and accuracy of measurements required and the effect of turbulence and ripples on the water surface. Float switches may be the cheaper option and with proven reliability, but are unsuitable for very shallow sumps such as may be provided in immersed tube tunnel sections. Level detectors for a wide, shallow sump need to detect much smaller changes in level than those in a narrow, deep sump, and will be much more susceptible to false readings caused by surface effects. Ultrasonics and radio frequency devices have the advantage of not requiring contact with the water.
- iii. Skimming equipment to remove oil, petrol or any other liquid that may float on the surface of the water in the collecting sump. A floating pump could be employed, or a floating weir with an outlet pipe leading to the suction side of a pump, which would then discharge the liquid through a separate pipe into a road tanker.
- iv. Sludge pumps may be necessary to remove deposits of solid matter in the invert of the sump and thus avoid the need for periodic cleaning by manual labour.
- v. A reflux (or non-return valve) and an isolating valve shall be provided adjacent to each pump. The isolating valve would normally be located

downstream of the reflux valve to enable maintenance to be carried out on the latter, as well as the pump. Valves shall be situated in an accessible place within the sump, pump room or valve pit.

- vi. Pipework for connection to a bowser vehicle to permit the sump to be emptied of spillages, independently of the main pumps or discharge pipework.

Discharge Pipework

7.57 Discharge pipework comprises the pipework, valves and fittings situated between the outlets from the pumps and the point of discharge. It may be a single or twin pipe system and incorporate hatch boxes if mechanical cleaning (by 'pigging') is planned.

7.58 Pipework shall be designed to avoid sharp changes in direction, in order to minimise friction losses and prevent erosion where abrasive suspensions can be expected to be carried.

7.59 Anchor and thrust blocks shall be provided where buried pipework incorporates spigot and socket joints.

7.60 Pipe fittings shall include air release valves and drain down points.

7.61 The choice of pipe materials and protective treatments will depend upon whether the pipework is buried, cast in, or in an open situation. Other factors will be the expected contaminants in the water, costs and ease of installation and maintenance.

7.62 The use of plastic and related materials shall be avoided in a tunnel, where, in the event of fire, toxic fumes could be generated.

7.63 Where flood banks or berms form part of the civil works it may be necessary to provide discharge arrangements on the berm that adopt principals indicated in Figure 7.3.

Safety Considerations

7.64 Typically, bifurcated duty and stand-by extraction fans shall be provided in sump areas. The normal operation of the fans shall be on an automatic timed basis for 15 minutes per hour (based on a minimum of four air changes per hour when running continuously). Suitable ducting shall be provided for the supply and exhaust air to the sump. Flame traps shall be incorporated, as necessary.

7.65 In order not to prematurely expel gases used for fire protection in the sump, the automatic fan system shall be interconnected with the fire prevention system's heat detectors so that the fan(s) are switched off upon detection of a rise in temperature, within the sump. Similarly, the gas detectors located in the sump shall switch off the fans in the event that a combustible gas, or oxygen deficiency, is detected.

7.66 To expel gas, a manual override for use by the fire brigade or maintenance personnel will allow the fans to be operated continuously from the pump control panel. Where gas is vented into the tunnel, this shall only occur in conjunction with operation of the main tunnel ventilation system. To ensure dilution below the explosive limit within the tunnel, where electrical equipment, etc may not be fully protected, a minimum design criterion of 1 part of sump gas to 50 parts of tunnel air shall be adopted. Where possible, provision shall be made to empty sumps before venting, as forced ventilation of a sump containing volatile fuel will generate excessive quantities of combustible vapour.

7.67 Detection of gas at low and high concentrations shall raise an alarm via the SCADA system, and shall also be displayed on the pump control panel. The alarm (high) condition shall normally initiate automatic operation of a fire extinguishing system, if fitted, to render the sump inert.

7.68 Where a nitrogen foam system is installed, nitrogen bottles shall be continuously monitored for gas levels to alert the TOA to any leakage and ensure that the bottles are fully charged and available to respond to an emergency.

7.69 Sampling from one of the gas detection system detectors shall take place just above water level. This can be achieved by attaching the sampling tube to a raft or float that can rise or fall with the water level.

7.70 The fire extinguishing system shall be initiated automatically upon detection by heat detectors, of a rise in temperature (to over, 600C) due to a fire in the sump and operable manually from a local fire control panel.

7.71 Spillage of hazardous or other substances which do not give off combustible gases, but which would be undesirable to pump into local water systems must be identified by the TOA using the monitoring and surveillance systems. Detection of substances, that reduce the amount of oxygen in the atmosphere, can be achieved by oxygen deficiency detectors arranged to set alarms when oxygen falls below a preset value.

7.72 On detection of a hazardous substance entering a sump, the detection system shall switch off the plant to allow manual operation and control.

7.73 All detector sensors shall be duplicated and internal detectors such as pelistors shall be capable of being replaced in-situ as they generally have a short life. Sensors need to be water protected.

Fire Precautions

7.74 Closed sumps shall have fire protection as detailed in Chapter 8.

7.75 Sump ventilation air supply and exhaust ducts, where connected into the tunnel atmosphere, shall be provided with flame traps. A combination of longitudinal gradient, crossfall and gully spacing controls the potential for large, flowing pool fires. To limit flame passage through the drains, in the event of a fuel spillage and fire, U-bends shall be incorporated, where there is adequate access for cleaning the drain, at the inlets to the sump and at the carriageway gully pots or traps, alternatively, equivalent "fire-proof" drainage systems may be considered.

7.76 Open sumps shall be sited approximately 10m clear of carriageways and buildings, and shall be accessible to the Fire Brigade should they need to extinguish any fire.

Operating and Emergency Procedures

7.77 Emergency procedures shall be detailed in the Tunnel Operator's Guide and include for dealing with hazardous spillages and fire.

7.78 Operating procedures shall include provision for removing hazardous material from sumps by specialist contractors.

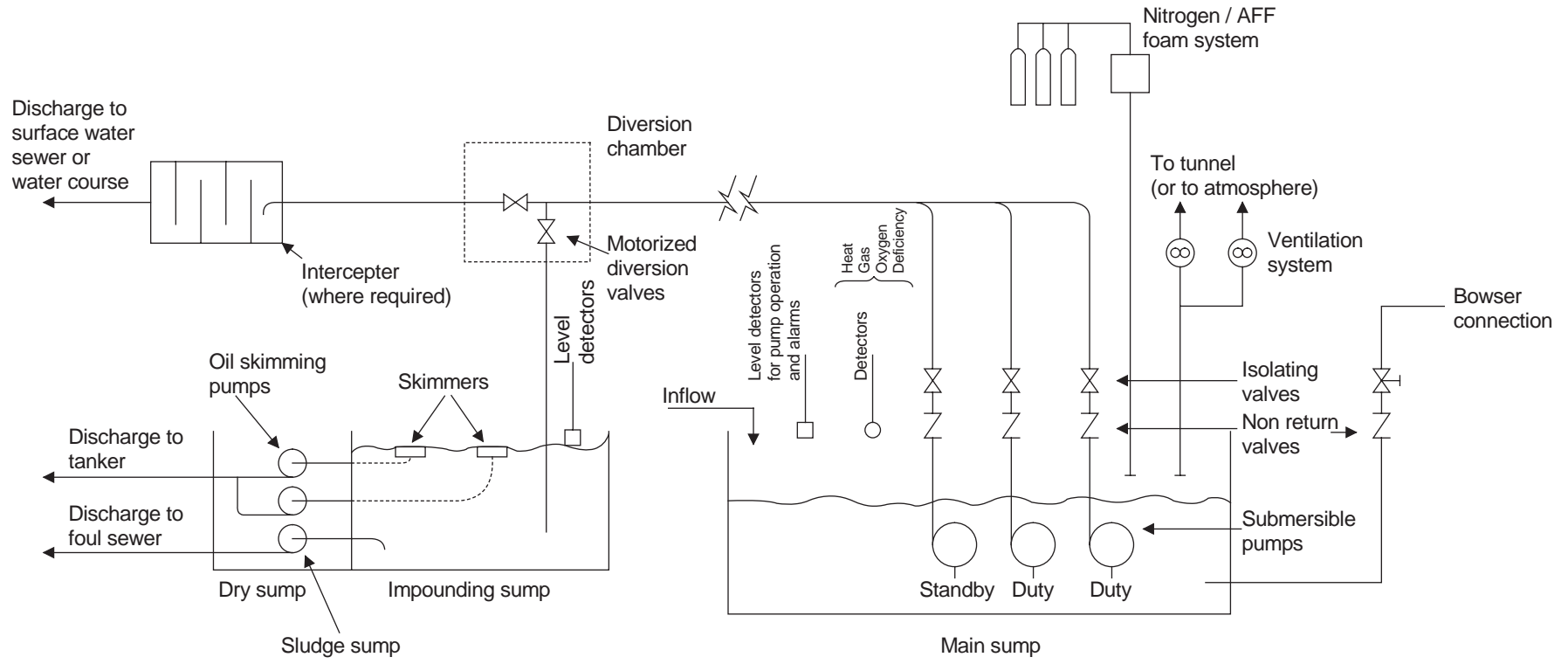

Figure 7.1

Typical Pumped Drainage System

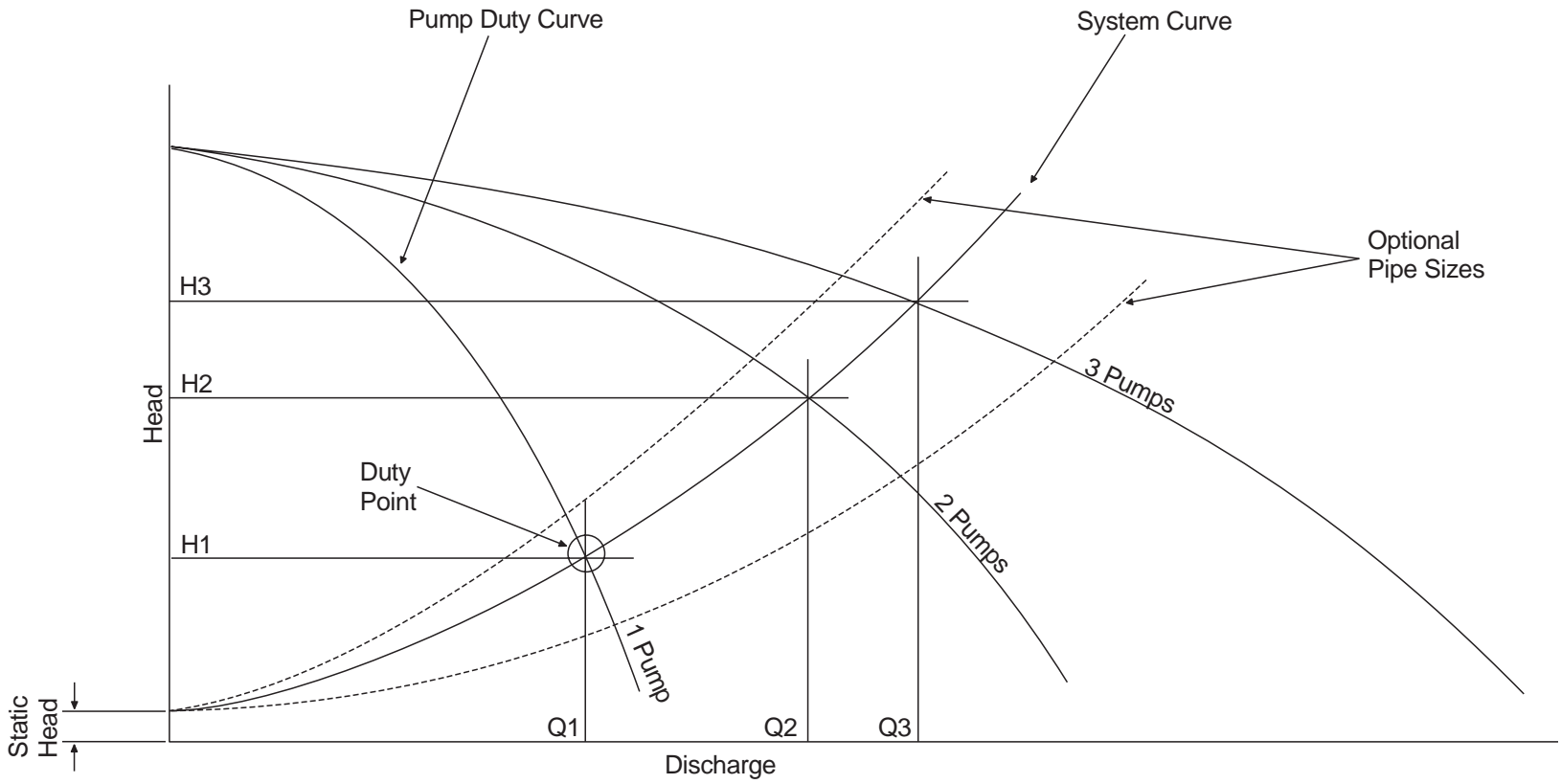

Figure 7.2
Typical System/Duty Curves for
Three Submersible Pumps Running in Parallel

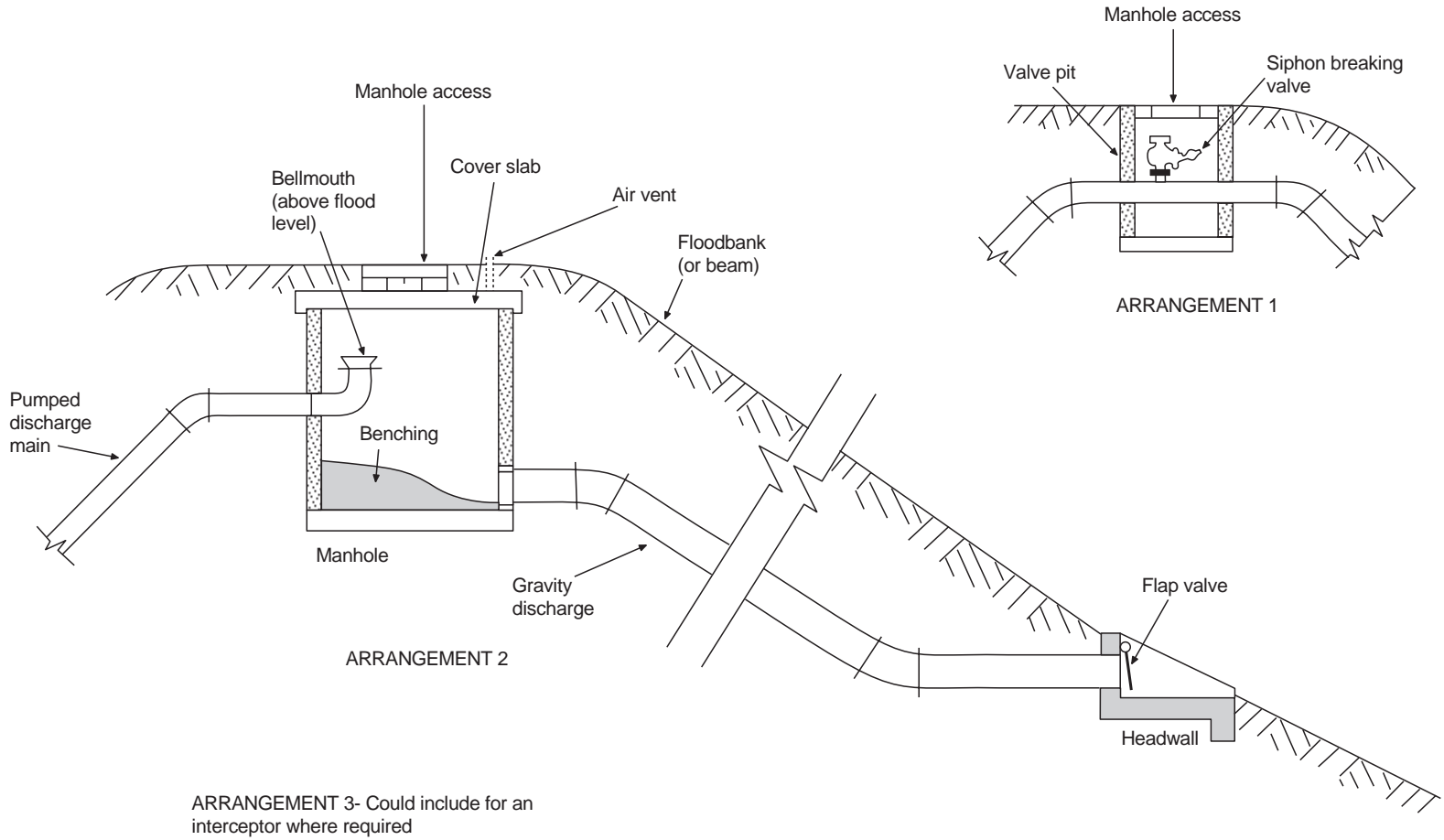

Figure 7.3

Optional Floodbank Discharge Arrangement

8. FIRE SAFETY ENGINEERING

General

8.1 This Chapter provides background information and technical criteria to be used for the fire safety assessment of road tunnels and plant and safety facilities to be provided as 'Active Fire Protection' for tunnel users. Further guidance is given on the criteria for the evaluation of fire loading to be used in Chapter 5 (Ventilation) and for the 'Passive Fire Protection' of tunnels in the form of protection to structural elements, cabling, mechanical and electrical plant and the fire and smoke resistance of doors, fixtures and fittings. Home Office Technical Bulletin 1/1993: Operational Incidents in Tunnels and Underground Structures: HMSO provides guidance on tunnel incident pre-planning, staged incidents, operational tactics and communications from the Working Group chaired by the Fire Service Inspectorate. This document, BD78 (DMRB 2.1) replaces the document "Draft Design Guidelines for Planning, Equipping and Operating Tunnels on Motorways and Other Trunk Roads, referred to. Further guidance will become available in PIARC: Fire and Smoke Control in Road Tunnels.

8.2 Fires in tunnels are particularly hazardous to life because of the potential concentration of fumes and poisonous gases, temperatures and heat radiation that can reach very high levels (1200°C and above), the possibility of panic among tunnel users and the difficulties which can be experienced by fire fighters working in an enclosed space. During evacuation, air temperatures of 80°C for 15 minutes, heat radiation of 2.5kW/m² (bare skin) and 5kW/m² (fireman in breathing apparatus for 30 minutes maximum) can be tolerated. Visibility in smoke of 7m (necessary to make steady progress by walking) and 15m (to be able to read signs) is required. Normal walking speeds of 1.5m/s may be reduced to 1.0 - 0.5m/s within smoke. A fire incident in a tunnel can cause congestion or blockage of the carriageways, both inside the tunnel and on its approaches, such that fire appliance access could be delayed.

8.3 Fire involving a heavy goods vehicle can be especially hazardous because of the large amount of fuel carried and the combustible nature of many payloads. Depending on the vehicles considered, fire loads for design purposes could range from 5 to 100MW. Since petrol tanker fires cause the most rapid and intense rises in temperature they are to be adopted as the basis for

design, checking and controlling fire effects in tunnels which permit such vehicles.

8.4 For longer tunnels, the first objective of using forced ventilation during a tunnel fire is to provide the conditions that allow the road user to escape safely from the site of the incident. This is achieved by either removing smoke from the tunnel tube (transverse ventilation systems) or by driving the smoke away from the escape route direction, normally in the direction of traffic flow, in order to protect vehicle occupants who may be trapped behind the incident (longitudinal ventilation systems). The second objective is to provide safe access to the fire by the emergency services, in order to control its spread and to extinguish it, thereby reducing the duration of the fire and its structural consequences.

8.5 Fire resistance of the tunnel structure is necessary to reduce the damage caused by the fire and minimise the time and cost of any reinstatement. Damage is dependant on both the fire load and the fire duration, the latter being determined by the capacity of the drainage and ventilation systems within the tunnel, the quantity of combustible material involved in the fire and the fire fighting provisions available. Cost benefit analysis may be used to make a case for either higher or lower fire loads than those specified for ventilation design, the latter being primarily dependant on life safety issues. For tunnels under rivers the consequences of relatively small areas of structural damage from fire, leading to flood inundation could be very serious.

Management of Fire Risk

8.6 Effective fire fighting, in response to emergencies, depends on a comprehensive approach to the management of the potential risks involved and entails appropriate communications, traffic surveillance and control, adequate ventilation and drainage systems, tunnel layout for safety, emergency lighting and preplanned and tested fire fighting procedures. Related active and passive protection measures are considered within the decision framework of Figures 8.1 and 8.2.

8.7 An essential part of active fire protection of the road user is the provision of easily accessible emergency points at regular intervals throughout the tunnel. Emergency points shall be equipped with fire extinguishers, hose reels, fire mains and hydrants as

agreed with the relevant local Fire Authority. Escape facilities (eg cross connection passages), appropriate communication procedures and effective means of smoke control shall also be agreed at an early stage in the design process. Usage, by the public, of equipment provision intended for minor incidents shall not be allowed to be prolonged, where any risk of escalation into a major incident may delay their safe exit from the tunnel.

8.8 Passive fire protection shall safeguard the structural integrity of the tunnel eg providing adequate cover to structural reinforcement, spalling resistance etc including protecting firemen from spalling material and falling equipment; protecting power and communications cabling and ensuring appropriate provision is made for the fire resistance of mechanical components within the tunnel. Consideration shall be given to the effects of high temperatures on the integrity of fixings and supports, particularly for heavy or suspended items of equipment such as jet fans.

Procedure for Designing Fire Protection

8.9 The design procedure for fire protection in road tunnels is illustrated in Figure 8.2 which shows the design steps to be taken and how these relate to Chapter 5 (Ventilation). The first step is to define a specific design fire load for ventilation, representative of the tunnel type and its location. Where different levels of structure and equipment protection, and fire smoke control ventilation capacity are to be provided, then the fire protection (or resistance) design load subsequently established may not necessarily match that used for ventilation design.

8.10 Once the fire protection design load is established, the size, temperature and duration of the fire can be estimated. Heat transfer calculations are then made to determine the temperature rise within the structure and this is compared for agreement with the structural design criteria specified for the tunnel.

8.11 If the tunnel fire protection fails to protect the structure to within the criteria specified, then further options shall be considered and the design amended accordingly.

Fire Quantification

8.12 The methodology for quantifying the fire protection size, duration and temperature is shown in Figure 8.1. The first step is the specification of the design fire load to be used in the design of the ventilation

system and the fire resistance required of the tunnel structure. Again, it should be understood that the ventilation design fire load does not necessarily match that used in the design of fire protection (resistance).

8.13 Having established the design fire protection load for the tunnel, its duration is calculated taking into account the effect of drainage in reducing the potential duration of a liquid fuel spill fire and any unavoidable loss from fire of fans and supply cables, reduced fan efficiency with less dense gases etc, which could prolong the duration. The fire size and spread of smoke are then estimated, giving consideration to the effects of tunnel gradient and ventilation. The fire temperature profile along the length of the tunnel can then be calculated and used with the fire duration to calculate the total heat that would be transferred to the tunnel structure and equipment. The following tunnel wall and ceiling temperatures may be used for guidance purposes:

- i. 400°C, passenger car fire (higher if flames reach walls etc)
- ii. 700°C, bus or small lorry (higher if flames reach walls etc)
- iii. 1000°C, HGV with burning goods (not petrol tanker)
- iv. 1200°C, petrol tanker (general case)
- v. 1400°C, petrol tanker (severe case, no drainage).

Design Fire Load for Ventilation

8.14 During a tunnel fire, the primary purpose of a ventilation system is to ensure the maximum opportunity for road users to escape from the site of the incident.

8.15 Table 8.1 defines the equivalent longitudinal ventilation design fire loads for road tunnels. The equivalent longitudinal ventilation design load is defined as that which produces an air flow velocity equal to the initial smoke velocity of the fire in a zero gradient tunnel. The strategy is based on deterministic and risk analysis arguments, as discussed.

8.16 A severe incident within a tunnel involving a petrol tanker spillage vapour fire may reach an intensity of up to 100MW almost instantaneously. The road gradient within the majority of road tunnels is sufficient to increase the spread of smoke so rapidly that ventilation is unlikely to be able to contain such a fire.

8.17 Incidents that do not involve a petrol tanker spillage may still reach fire intensities of up to 100MW, such as those involving the larger, fully-laden HGVs, but the fire will take a longer time to reach the maximum intensity, as its rate of growth is determined by its spread to adjacent combustible items of the vehicle and its cargo. A lower ventilation design load of 20MW should allow sufficient time for the road user to escape before the fire has grown to its maximum intensity.

8.18 Based on consideration of traffic volume, traffic composition, traffic speed and generic tunnel design, risk analysis can identify tunnel categories and lengths where the probability and consequences of major fire incidents are small. For such tunnels, on non built-up routes or shorter tunnels on built-up major routes, a lower design load, as given, is warranted.

8.19 Table 8.1 gives guidance as to the minimum ventilation fire load to be used when designing the ventilation system of a road tunnel and is based on the ventilation sufficiently slowing the smoke spread to allow evacuation of the public from the site of the incident via emergency escape doors etc. The absence of escape passages in older tunnels may indicate a need to consider a higher ventilation fire rating. Also, the imposition of restrictions on hazardous goods is almost impossible to enforce totally under current circumstances and should be discounted as it cannot be guaranteed that vehicles carrying hazardous loads will never use the tunnel.

8.20 To allow emergency services to extinguish a fire, the spread of smoke must be stopped completely in the direction of access to the incident. Therefore, the required ventilation load may be higher than that given in Table 8.1 and an increase of the design load may need to be considered, based on cost-benefit arguments.

Design Fire Loading for Structural Fire Protection

Vehicle Fire

8.21 Fire loads from single vehicles and their associated combustible contents are given in Table 8.2. Note that the values given are typical and there will be variation in fire load between different vehicles within each classification. A tunnel fire could involve the combustion of components of its construction, but it can be assumed that this contribution is small in comparison to that of the vehicles and their contents. The value for the HGV is based on the assumption that it has a full load of highly flammable material.

8.22 The choice of fire load for tunnel protection design will be dependant on the tunnel location and road type. A maximum fire load of 100MW should be used if fires involving HGVs are reasonably probable with respect to their numbers using the tunnel. Otherwise, the maximum non-hazardous vehicle fire load can be assumed to be that of a lorry or coach, ie 20MW. The final choice of fire load will depend on the cost-benefit of increased fire protection in comparison to increased reinstatement costs etc if a fire incident occurs.

Hazardous Goods Vehicle Fire

8.23 Incidents involving hazardous goods vehicles may result in the spillage of eg hydrocarbon fuel, either in its gaseous or its liquid form. Leakage of liquid hydrocarbons, typically petrol, will result in pool fires upon ignition. However, the consequences of a release of liquified petroleum gas (LPG), due to its high volatility, will be different to those of a petrol spill. The combustion events associated with gaseous releases from LPG vehicles are, in general, more intense and may include jet fire, fireball and vapour cloud explosion effects in addition to pool fires. The additional consequences of gaseous releases will need to be considered.

8.24 The heat output of a pool fire will depend on the liquid pool dimension which in turn depends on the leakage rate from the tanker. The total heat output from the fire is calculated using a value of 43.7MJ/kg for the heat of petrol combustion.

8.25 The exact leakage rate from a damaged tanker is not predictable, but it can be assumed that the reduced supply of air within a tunnel will limit the fire intensity to 100MW. As for vehicle fires, the final choice of design fire load will depend on the cost-benefit of using increased fire protection in comparison to increased reinstatement costs if a fire incident occurs. Proposals to design for 200MW (petrol tanker) and 300+MW (immersed tunnels) vehicle fire loads have been proposed overseas.

8.26 Fire intensity is limited by supply of air within the tunnel rather than supply of fuel to the fire. The spill rate required to produce the maximum fire intensity of 100MW will be higher when drainage is effective. The effect of drainage is to reduce the duration of a fire and not to reduce the maximum intensity.

Environmental Issues

8.27 In addition to the structural and life safety implications of a fire within a tunnel, there is also a

potential threat to the environment. Particular consideration shall be given to the effective dispersion of smoke and to the disposal of water used for fire fighting, both of which may contain significant concentrations of toxic substances.

Active Fire Protection Requirements

Emergency Points in Tunnels

8.28 A typical layout for an emergency/distribution panel point is given in Figure 8.3. Emergency points shall be positioned in accordance with Chapter 3 and as a minimum shall include:

- i. Two portable fire extinguishers for all types of fires, in suitable cabinets
- ii. Hose reel (if required by fire brigade) connected to a fire main, to extinguish non-electrical fires
- iii. A telephone connected directly to the police or traffic control centre
- iv. Socket outlets on UPS for fire brigade power tools, see Chapter 11
- v. Permanently illuminated emergency signs
- vi. For longer tunnels, illuminated distance signs to communicate the distances to the nearest exits, upstream and downstream, are of benefit in an emergency eg installed signs at Mersey Tunnels.

8.29 Doors to hose reel and extinguisher cabinets shall have micro switches to give an alarm signal, to the police or traffic control centre, when a door is opened or a fire extinguisher is removed. A facility in the cabinet shall indicate to the road user that this alarm signal has been received.

8.30 Emergency points (EPs) may be amalgamated with the electrical distribution panels to form emergency/distribution panels (EDPs). The electrical distribution section shall be segregated. See Chapter 11.

Fire Extinguishers

8.31 Portable fire extinguisher types shall be to (13 A) fire ratings of BS EN 3 Part 1, either dry-powder, stored pressure type with a pressure gauge and coloured red with a blue label, or AFFF (Aqueous Film Forming Foam) electrically tested, complete with CO₂ charge container and coloured off-white for ease of identification.

Hose Reels

8.32 Hoses shall be installed, in maximum sectional lengths of 30m of 19mm internal diameter hose (assuming that emergency points are located at 50m centres), to enable discharges from adjacent hoses to overlap. Water flow rate and pressure shall be to BS EN671-1:1995. Hose reels may be fed from the tunnel fire main and may need pressure reducing valves. To prevent hose reels from freezing in winter, they shall be provided with trace heated branches from the fire main and be installed in a closed compartment containing a low wattage electrical tube heater. Hose reels shall normally be of the swinging arm pattern, but physical limitations in the tunnel may require a fixed pattern, with a fairlead, to be used. The hose reel isolating valve shall not be accessible to the public and should be left in the "ON" position at all times. Drawing the hose off the reel shall automatically start the flow of water into the hose and the nozzle valve shall control the water jet.

Fire Main and Additional Hydrants

8.33 One fire fighting supply main will normally be provided for each one way bore of a twin-bore tunnel (one main on each side for a single-bore two way tunnel). Mains shall comply with Local Water Authority and Fire Brigade requirements. To ensure security of supply, each end of the fire main system shall, wherever possible, be supplied from an independent water source and be fitted with suitable isolating valves. The water authority may insist upon break tanks being installed. A pumped system would then be needed to achieve the required fire fighting capacity. This would also apply when water pressure could drop below minimum requirements. Water meters, if installed, are likely to be sized for routine tunnel water requirements and so will not be adequate for the full emergency fire fighting flow. Meter by-pass valves shall be installed and clearly and permanently marked to facilitate rapid by-passing of the meter during an emergency.

8.34 Hydrants in the tunnel shall be horizontal, bib nosed or oblique pattern landing valves to BS 5163, branched off of the fire main and located at approximately 750mm above the walkway or verge. Hydrant numbers and locations shall be as agreed with the fire brigade and any not incorporated into emergency point cabinets be placed in individual, lockable, hydrant cabinets. Where fire hydrants are required outside, in the tunnel approaches, they shall be of the underground type and located in the verge. The required flow of water, the minimum running pressure and the maximum design working test pressure of the hose and hydrant system and the capacity of break tanks (where required) shall be

to the requirements of BS 750, BS 5041:Part 1 and BS 5306:Part 1, subject to any particular written requirements of the Local Water Authority and Fire Brigade.

8.35 Hydrants shall be suitable for use with hoses to BS 3169.

8.36 Pipe sizes are likely to range between 100mm to 200mm, depending on pressure drop considerations. Pipe couplings used with steel pipes shall be of a type that eliminate the need for pipe anchoring. Ductile iron pipe shall be provided with spigot and socket joints. These require to be anchored at changes in direction and gradients.

8.37 Fire mains shall be protected against freezing, in order to ensure that a supply of water for fire fighting purposes is always available for use by the Fire Brigade. Dry mains shall be avoided, since the lengths of pipework involved make the delay time required to fill the pipe in emergency unacceptable.

8.38 Typical requirements for protection include thermal insulation of the main throughout the tunnel with trace heating 50m in from each portal and at branches to the hydrants. Outside the tunnel, no thermal protection should be necessary where the main is buried in ground at a depth of 1m or more.

8.39 When selecting the most appropriate type of thermal insulation, the designer needs to consider mechanical durability, rot and vermin protection and ensure that the material selected shall not give off toxic fumes, if subject to fire.

8.40 Factory applied bitumen lining and bitumen outer wrapping will, in most cases, provide adequate protection against corrosion of steel pipe. Corrosion protection shall be applied, on site, to joints, valves and pipeline equipment to ensure continuity of protection. Similar treatment can apply to ductile iron pipe and fittings, with the addition of a polyethylene tubular film protective sleeving to BS 6076 where the pipework etc is buried in the ground.

8.41 Section isolating valves, normally at quarter points, shall be installed along the fire main within the tunnel for installation and maintenance purposes.

8.42 Automatic air release valves and drain down points shall be provided.

Public Emergency Roadside Telephones

8.43 Details of the emergency roadside telephones are given in Chapter 9.

Communications

8.44 The emergency services communications systems are detailed in Chapter 9.

Escape Routes: Cross-Connecting Passages and Doors

8.45 Cross passages are installed to assist in fire fighting and emergency egress/access, in accordance with the requirements of Chapter 3. A typical cross-connecting passage door layout is shown in Figure 8.4

8.46 Each cross-passage shall be identified by a clearly visible number (not shown in Figure 8.4) to assist with location in respect to an incident. The tunnel operating procedures shall clearly define the need to minimise the risk of people using cross-passages and emerging into the path of moving vehicles in the unaffected bore. Where there is room not to impede the vehicles of the emergency services during an incident, consideration may be given to the provision of demountable pedestrian barriers, opposite the doors only, to prevent users of the cross-passage doors moving into the live carriageway of the adjacent bore.

8.47 Cross passages shall be fitted with double-swing, self-closing doors. Doors shall be a minimum of 914mm wide and any associated stairway shall be at least 1.12 m wide. Doors shall be of stainless steel, fitted with wired glass vision panels, to enable users to be aware of the traffic conditions on the opposite side. The complete door assembly including doors, frames and fittings shall be made from materials capable of two hour fire resistance. Doors shall be of a good quality and fit such that smoke does not pass when closed.

8.48 The opening of a cross passage door leading to a live carriageway shall activate suitable signals to warn drivers approaching the tunnel of the possible presence of pedestrians in the tunnel roadway.

8.49 Switches shall be fitted to indicate when doors are opened, they shall be of a type that do not give spurious signals when doors are subject to wind movement due to passing traffic.

8.50 To assist the Fire Brigade, standard connections, contained in stainless steel connector boxes, as shown in Figures 8.5 and 8.6, shall be provided through the wall close by the cross passage doors. A 50mm duct for a

communications cable shall be provided as well as a fire hose connector.

8.51 Fire hose connections shall have 65mm instantaneous couplings. A hand control valve shall be incorporated in the female coupling. The siting of the inlet and outlet shall be adjacent to the cross passage door jambs, 200mm to 600mm to the side, and between 800mm to 1000mm from the verge. The connections shall be arranged so that they are effective from either carriageway. The female outlet shall always be to the left when passing through the cross-passage doors. The inlet and outlet shall be conspicuously labelled "FIRE BRIGADE HOSE INLET" and "FIRE BRIGADE HOSE OUTLET".

8.52 Recessed connections for breathing apparatus (BA) communications cable shall be provided together with steel ring bolts approximately 80 to 100mm in diameter for use as BA guide line anchorage points, one on each side of the door in each bore and at agreed locations along the tunnel walls, at a height of 1m above the verge.

8.53 The standards for these connections shall be agreed with the Fire Brigade(s) concerned, to ensure compatibility of equipment.

Smoke Control Panels

8.54 For tunnels with mechanical ventilation, smoke control panels, normally located outside both portals of a bore, provide localised control of the ventilation by the Fire Brigade. This is discussed in Chapter 5. The method of operating the ventilation system for smoke control shall be included in the Manual for Police and Fire Services described in Chapter 13.

Automatic Fire Extinguishing Systems in Tunnels

8.55 Automatic fire extinguishing systems are not considered suitable for the traffic space. Total flood gaseous systems and foam systems are not practical where people are present in vehicles. Water sprinkler systems may cool buoyant smoke causing immediate smoke logging of the tunnel and producing potentially explosive air/vapour mixes.

Passive Fire Protection

Tunnel Structure

8.56 The effects of fire on the tunnel structure and associated ducts and shafts shall be carefully assessed according to the characteristics of the fire to be taken

into account. Critical elements shall be identified and designed for the circumstances pertaining at individual sites. Additional guidance for tunnel structure (electrical circuits and equipment, see below) is contained in reference, Fire in Road Tunnels: Protection for civil engineering structures, electrical circuits and equipments: WRA (PIARC) Routes/Roads, No 275, III: 1991. The International Tunnelling Association (ITA) is currently undertaking further work in this field.

8.57 Depending on the design fire to be resisted, additional fire protection layers to structures may not be required eg where the structure comprises cast iron segments or where reinforced concrete with adequate cover is used, as these materials are inherently fire resisting. Some damage may occur in the event of a fire without causing failure of the structure. Provision of additional mesh reinforcement may contain spalls of reinforced concrete sections, particularly in more vulnerable upper walls and ceilings.

8.58 Where there is exposed structural steelwork in the tunnel such as at ventilation shafts, two hours fire protection of the steelwork is required to reduce the risk of collapse. This may be obtained by enclosure in suitable fire resisting materials or by coating/spray methods.

Cabling

8.59 Low smoke zero halogen (LSOH) insulation and sheathing materials shall be used for all cables inside a tunnel in order to minimise the hazards of smoke and toxic fumes arising from burning cable insulation. Normal cable compounds such as PVC give off fumes and halogen gases which, when combined with moisture, form toxic and corrosive acids. Where very short lengths (less than one metre) of low voltage communication cables are required, engineering judgement shall be used to assess whether the potential risks are low enough for the LSOH requirements to be relaxed.

8.60 All cables shall be enclosed in cable ducts. The walkway or verge ducts shall be designed to be two hour fire resistant against a 250°C temperature, with the covers in place. Smoke/fire barriers shall be installed at intervals of approximately 50m within each duct and at junctions to prevent the unrestricted spread of fire or combustion products.

8.61 The terminating chambers of equipment shall have a minimum two hours fire resistance and care shall be taken to ensure that the fire resistant characteristic extends over the cable entry into equipment mounted on the walkway, or verge ducts. If there is any possibility of

combustible gases permeating unventilated ducts, cable chambers etc suitable provisions or prevention will need to be made at the detail design stage.

Secondary Cladding

8.62 For tunnel structures provided with a separate secondary cladding finish secured to a support framework off of the main structure, fire stops shall be provided within the void at approximately 30m intervals. See Appendix A.

8.63 Cladding shall be non-combustible and made from material that prevents toxic gases, or smoke being generated in the event of a tunnel fire. Any material which satisfies the Category 1 compliance criteria for panelling as given in Table 1 of BS 6853: 1987, may be considered. In the absence of any suitable Standard for the testing of the products of combustion for toxicity, reference may be made to the Naval Engineering Standard NES 713 Issue 3, March 1985, or latest.

Services Buildings and Plant Rooms

General

8.64 All buildings and ancillary structures shall be zoned and provided with one or more fire alarm systems to a suitable standard. Where such buildings or areas are not manned, automatic fire detectors shall be provided and monitored remotely, both for immediate detection and location of the fire and for fault detection.

8.65 Means of escape, portable fire extinguishers, hose reels, hydrants, foam inlets and dry risers shall be provided in buildings and structures in accordance with local fire regulations. Portable extinguisher types include CO₂ dry powder, foam, Aqueous Film Forming Foam (AFFF) or water. Suitable equipment shall be provided related to the potential risk.

8.66 Fixed fire fighting protection shall be installed to all drainage sumps and plant areas containing electrical switchgear, communications and control equipment and generator plant.

Halon and Alternative Systems

8.67 The "Montreal Protocol on Substances that Deplete the Ozone Layer" prohibits the use of Halon fire extinguishing systems in new installations (with very few exceptions) and production of Halons 1211 and 1301 has ceased.

8.68 Recycled halons continue to be available, but only for use in existing installations employing Halon 1301 (the only fire extinguishing Halon with a low enough toxicity to be considered for this purpose).

8.69 Human exposure to Halon 1301, at a concentration of 5% by volume, shall be limited to a maximum of 10 minutes. Five per cent concentration is sufficient to extinguish most fires. Any undue exposure shall be avoided.

8.70 Effective monitoring, testing and servicing procedures shall be used to minimise accidental release of halon. Alternative simulation gases which are environmentally acceptable such as Sulphur Hexafluoride (SF₆), or chlorodifluoromethane R22 shall be used for testing halon systems.

8.71 A number of alternative chemical fire suppressants, claimed to be environmentally acceptable and capable of sustaining life, are available, many of which are based on breathable mixtures of argon and nitrogen. Designers shall evaluate available options, considering performance, environmental and health issues, availability and Fire Authority approvals, during the design stage.

Automatic Total Flooding Carbon Dioxide (CO₂) Systems

8.72 Carbon Dioxide systems are well proven, but require stringent safety precautions with regard to locking off, signs, warnings and operating procedures. The potential hazard is asphyxiation, particularly as CO₂ is heavier than air.

8.73 A total flooding CO₂ system comprises banks of compressed gas storage cylinders with a system of fixed distribution pipework and discharge nozzles, installed over the areas of risk. Discharge shall be controlled from a fire panel operated by detectors, with a warning given by a sounder distinctive in sound to that of the fire alarms. Mechanical control, automatic by fusible link, or manually by pull release, may also be used.

8.74 An electro-mechanical lock-off, consisting of a solenoid operated catch operated by a key switch, which will prevent the automatic release of CO₂ by the automatic sensing units, shall be provided in all areas which are likely to be occupied (even for short periods) and are protected by total flooding CO₂ systems.

8.75 Complete room sealing is essential for gaseous extinguishers to be effective. Top up facilities shall be provided for the interim period of repair if a leakage path occurs.

8.76 Rooms protected by such systems require ventilation equipment to be provided to clear the gases following discharge of CO₂ before the room is entered.

Sprinklers and Water Mist Systems

8.77 Sprinkler systems perform three functions; to detect a fire, to sound an audible signal and to contain or extinguish the fire. Sprinklers contain and extinguish a fire by a cooling action. They have the disadvantage of causing thermal shock and water damage to electrical equipment and, because they are automatic may create unacceptable damage if the water supply is not turned off once the fire has been extinguished.

8.78 Water mist systems, which generate a fine, dense mist of water droplets may also be suitable for some applications in service buildings, but require careful design to ensure safety with the high operating pressures involved.

Drainage Sumps Connected to a Tunnel Carriageway

8.79 Fixed fire fighting protection shall be installed to all such drainage sumps. Sumps shall be provided with hydrocarbon gas and oxygen deficiency detectors to deal with the effects of a hazardous spillage. See also Chapter 7.

8.80 Closed sumps shall have fixed nitrogen foam systems, for fire protection or making inert. Additionally, a dry inlet shall be provided for the remote application of foam by the fire brigade.

8.81 Sumps may contain an explosive and/or flammable atmosphere on occasions and electrical equipment shall be provided with a level of protection, see also Chapter 7.

Automatic Foam Systems

8.82 Foam concentrate shall be of the alcohol compatible Fluoroprotein or AFFF type and shall be used for extinguishing fires in sumps. Foam application and expansion rates shall be in accordance with the appropriate standards.

8.83 A foam system may be initiated by detectors, fusible link, or manual release etc. Foam may also be discharged upon detection of combustible gas.

8.84 Types of system include:

i. Premixed Foam System - this comprises the storage of foam concentrate, premixed with

water, and stored in tanks adjacent to the area to be protected. Foam is ejected under pressure provided by a bank of CO₂ bottles.

- ii. Foam Generators - these operate by injection of foam concentrate into a water supply via a proportioning device. Water Authority approval is necessary if a direct connection to a mains water supply is required.
- iii. Nitrogen Foam System - a system using compressed nitrogen can be more compact. The use of an inert gas has the advantage of making a sump inert in the event of a combustible atmosphere forming.

8.85 Where foam is intended to be in place for protecting a sump for a prolonged period, facilities shall be provided for the injection of additional foam to top up the foam blanket by the Fire Brigade, as necessary. Where such provision is made the designer and TOA shall ensure that the foam used for the automatic system is compatible with any foam that may be used by the Fire Brigade.

Road Tunnel Length/Type	Equivalent Ventilation Design Load (MW)			
	Motorway	Urban Major Route	Rural Major Route	B Route
Length > 2000m	50	50	20	20
Length < 2000m	50	20	20	20

Table 8.1 Equivalent Longitudinal Ventilation Design Fire Loads (minimum values)

Vehicle Classification	Fire Load (MW)
Car	5
Van	15
Coach/Lorry	20
HGV, fully laden	30 –100

Table 8.2 Vehicle Fire Loads

Open Road Type	Injury Accidents	Deaths
Motorway	9	??
Dual Carriageway *	10	
Single Carriageway *	11	
Urban Roads **	30	

* link rates, well clear of junctions

** lower limit taken

Table 8.3 Injury Accident And Death Rates On The Open Road (per 100 million vehicle kilometres travelled)

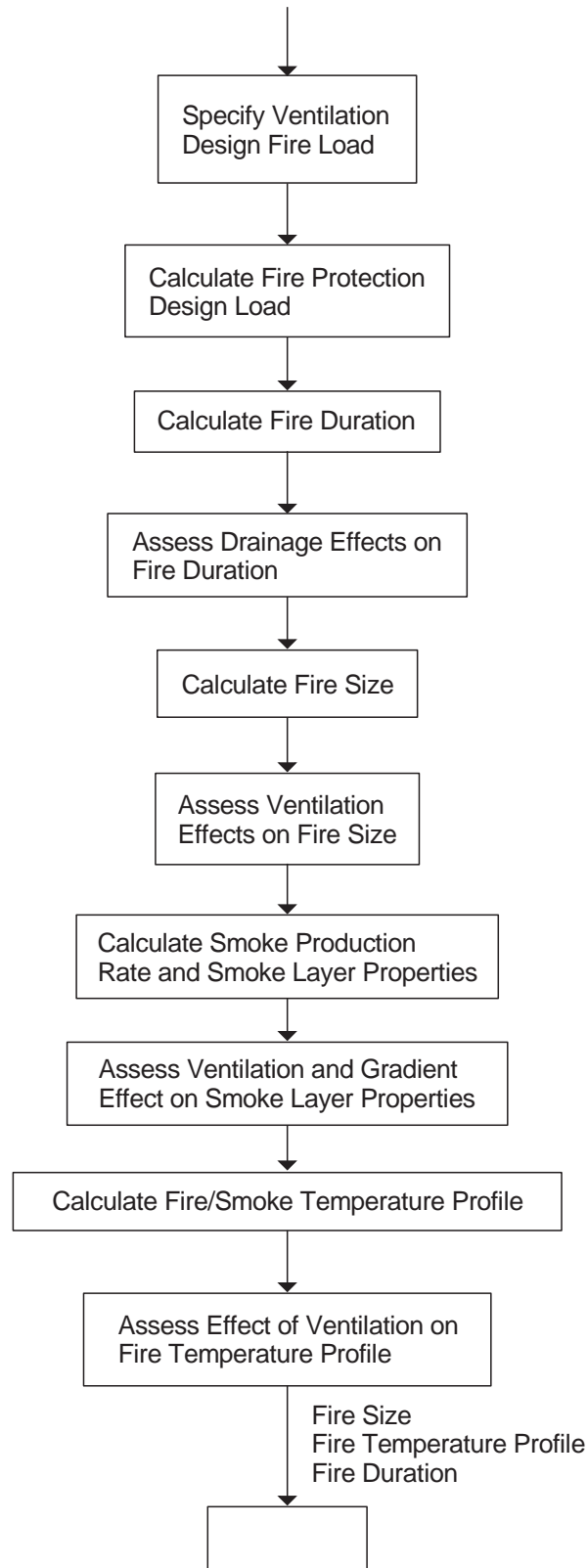

Figure 8.1 Fire Quantification Methodology

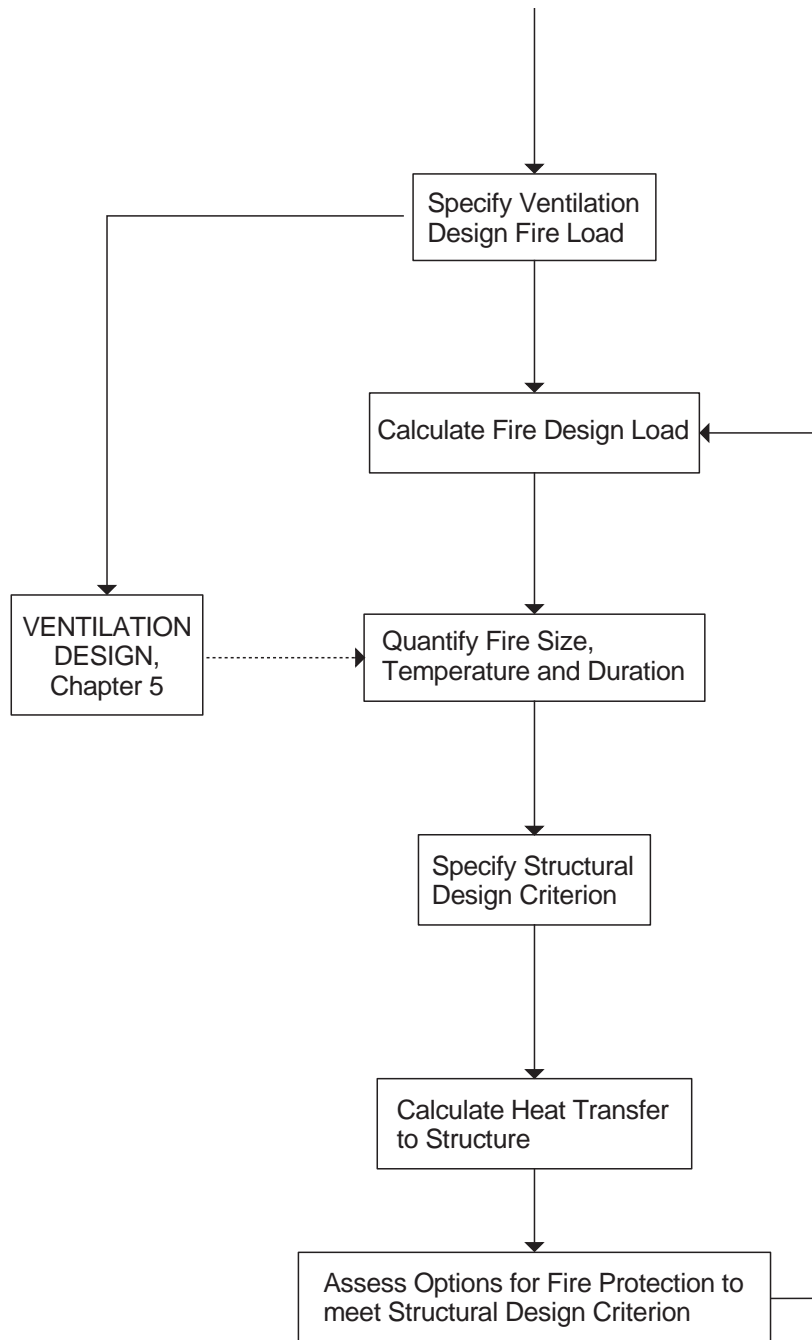

Figure 8.2 Procedure for Design of Fire Protection in Road Tunnels

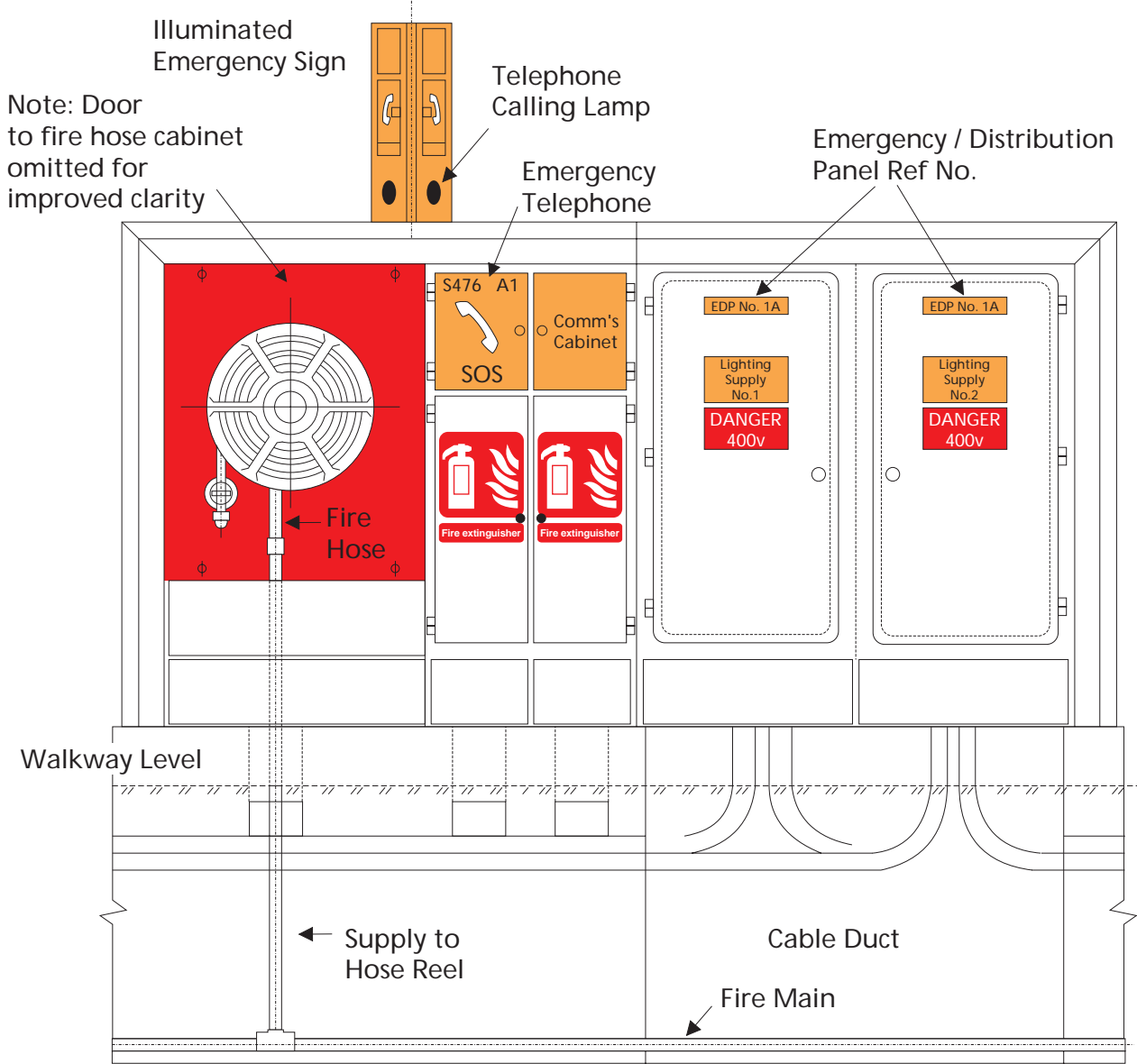

Figure 8.3 Typical Emergency / Distribution Panel

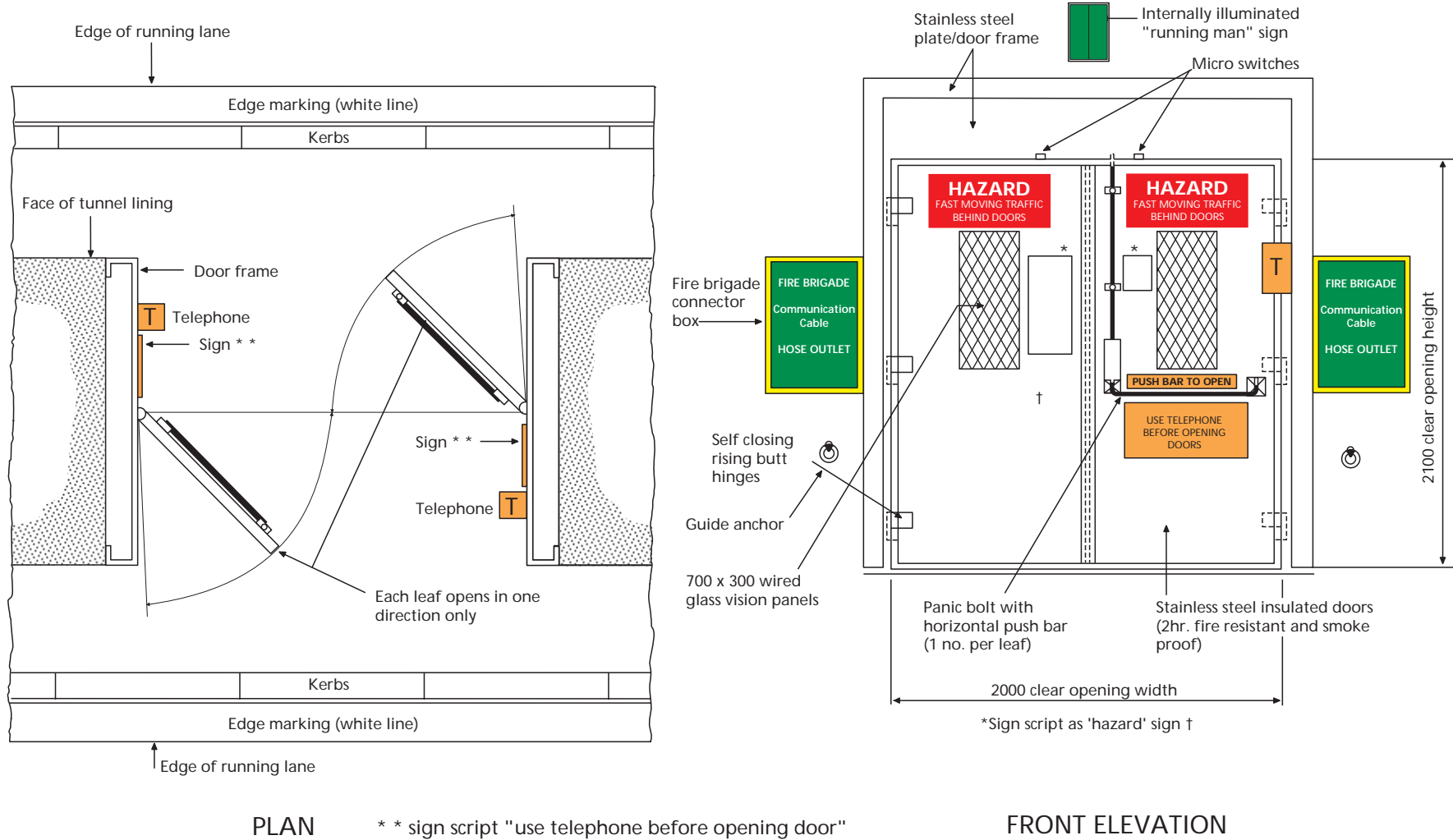
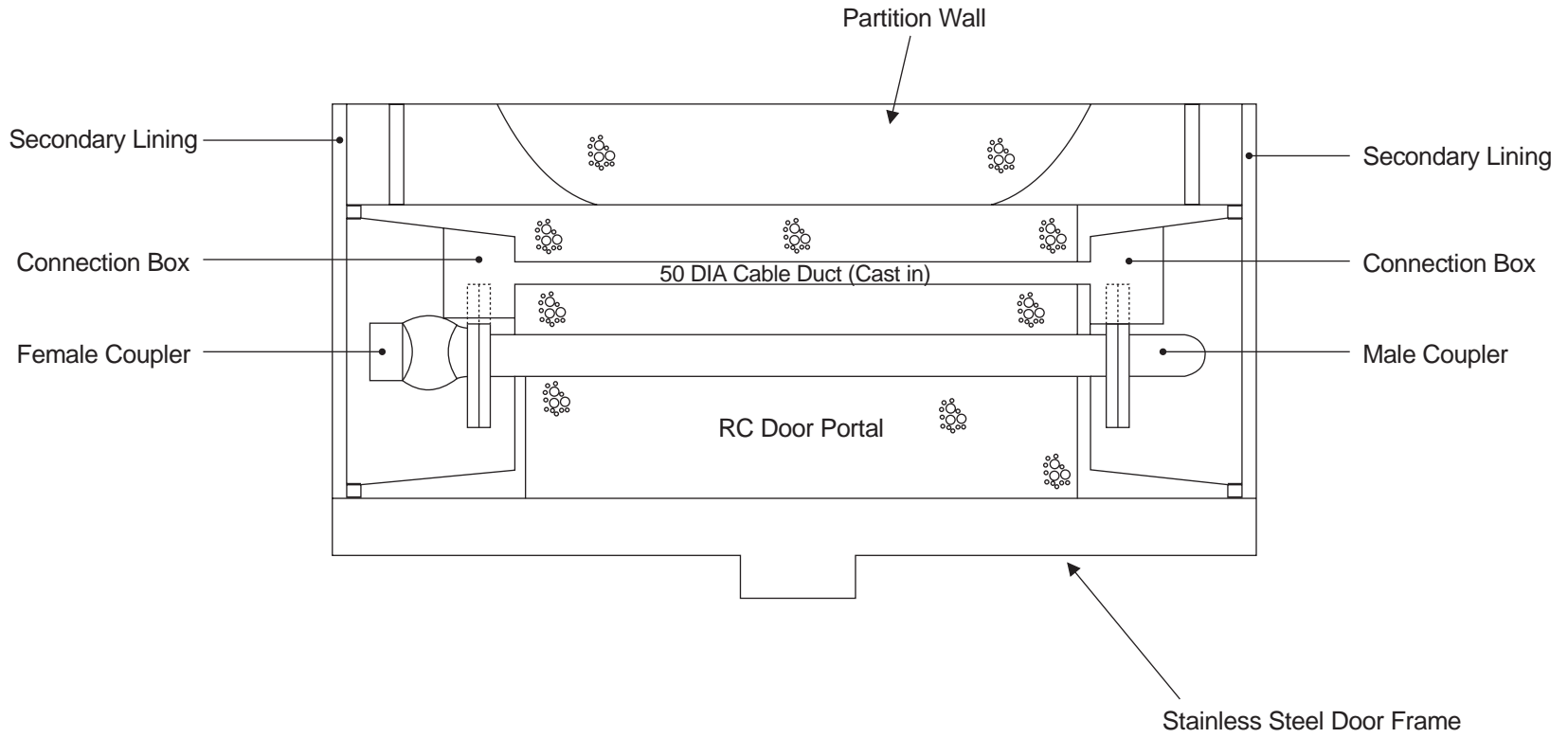

Figure 8.4

Example Tunnel Cross Connection Doors



**Detail of Fire Brigade Connectors on Side of Doorways
(Section in Plan)**

Figure 8.5

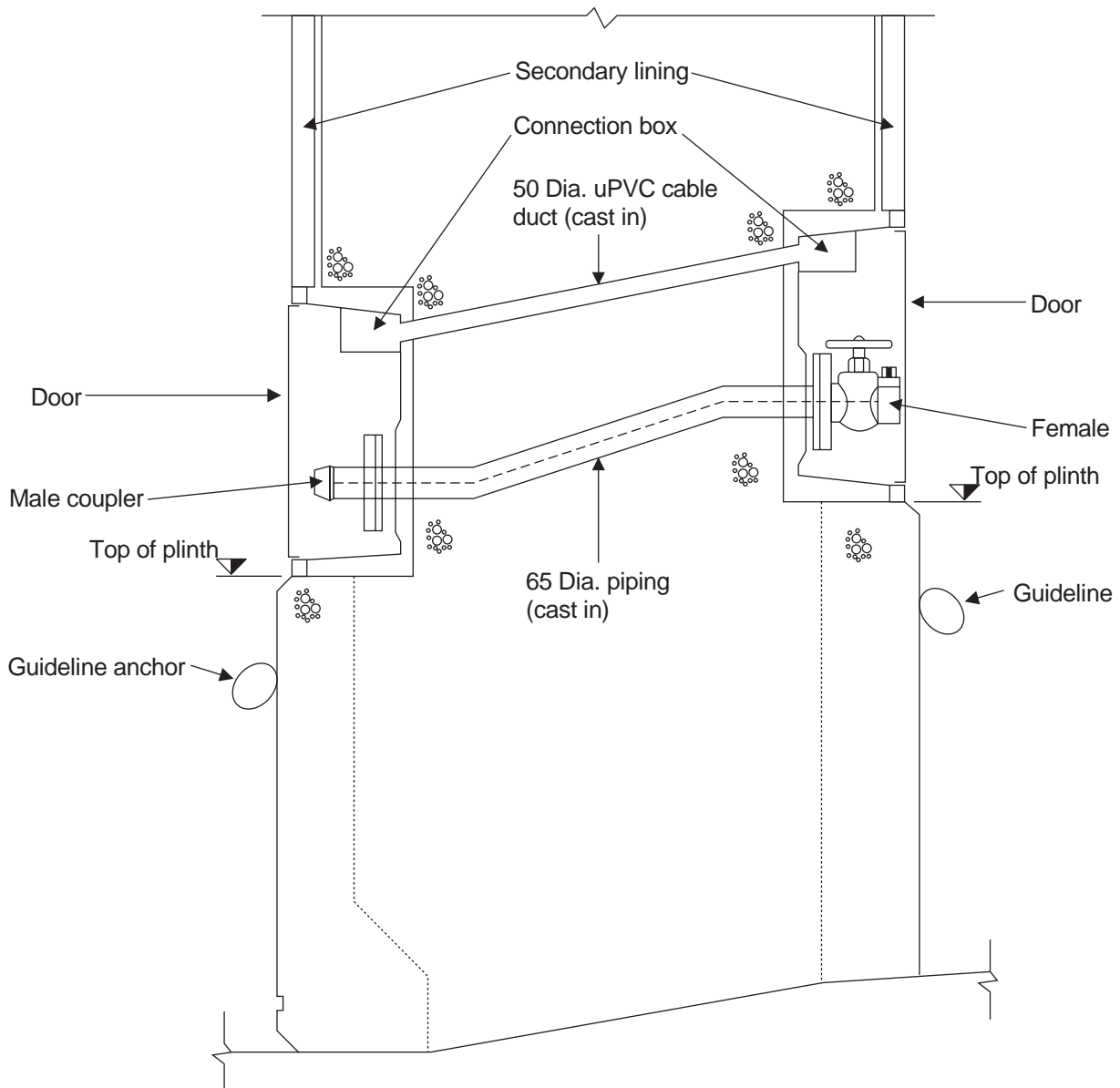

Figure 8.6 Detail of Fire Brigade Connectors
(Section in Elevation)

9. TRAFFIC CONTROL, COMMUNICATIONS AND INFORMATION SYSTEMS

General

9.1 This Chapter describes the provisions to be made for the design and authorization of traffic control, communications and information systems for tunnels. Reference to tunnels includes the relevant approach and exit roads coming within the limits of the operating regime for the tunnel that have been jointly agreed between the Design Organisation, the Police Traffic Controller and authorities responsible for maintenance and operation.

9.2 Traffic management and communication systems ensure the safety of tunnel users and personnel employed in tunnel maintenance and operation. A range of electronic equipment is deployed to monitor and control traffic flow, transmit alarms, alert emergency and breakdown services and maintain contact between traffic controllers, tunnel operating authorities and relevant emergency services.

9.3 To provide appropriate levels of safety over the full range of operating conditions, facilities for traffic management and tunnel communication shall be fully integrated with the operation of systems installed to monitor and control the tunnel environment, see Chapter 10. Tunnel systems shall interface with standard communication and signalling systems used on the adjoining motorway or other trunk road networks.

9.4 System design will be related to the layout of the tunnel and its safety facilities eg emergency points and escape routes. The structural form of a tunnel will determine the space, beyond the traffic gauge, that is available for positioning the necessary equipment, see Chapter 2.

Communications for Motorways and Other Networks

9.5 Communication and signalling systems used to monitor and control traffic for motorways and other trunk roads shall be of a type approved, in writing, on behalf of the Secretary of State, or appropriate Authority. In England and Wales, shall be to the requirements of the National Motorways Communication System (NMCS), a computer controlled network operating signals, telephones and other devices. In Scotland, a system utilising a

combination of the National Driver Information and Control System (NADICS) and locally distributed control offices shall be used. In Northern Ireland, signs and signals used for traffic control shall meet the requirements of Traffic Signs Regulations (NI) 1997, equipment shall have an approval issued on behalf of the Department of Environment (NI), advice on responsibilities/approval for signing/signalling shall be sought from Roads Service Headquarters.

9.6 Monitoring of traffic and other activities is achieved by combinations of closed circuit television (CCTV), CCTV alert and incident detection, and emergency telephones placed at regular, fully referenced intervals. Traffic is controlled by fixed signs, variable and enhanced message signs (VMS, EMS), matrix signals and portal/lane control signs, according to specific needs. When hazards arise, variable signals display appropriate warnings to slow or redirect traffic or warn of lane closures.

Control Centres

9.7 Police Traffic Control Centres (TCC) are normally directly responsible for all matters concerning traffic management and the initial response to breakdowns, accidents and emergency situations that affect a tunnel road user. Usually, the Police TCC will be remote from the tunnel and a tunnel will have, in addition, its own dedicated centre for the management of tunnel systems. The latter is usually in a Tunnel Services Building (TSB) located in close proximity to the tunnel, or it can be at a location remote from the tunnel particularly if the TSB is unmanned. A Tunnel Management Centre (TMC) is normally responsible for traffic management involving maintenance operations such as temporary signing in accordance with Chapter 8 of the Traffic Signs Manual. The TMC may also be party to all aspects of traffic information communication and signal control, provided appropriate procedures are agreed with the Police Controller on the understanding that overall responsibility for initiation and control of traffic signals remains with the Police.

9.8 Matrix Signals are set by the Police, in Control Offices, via computer controlled systems. Such systems automatically calculate and set additional aspects on adjacent and nearby signals, in order to display a safe sequence to the road user. Calculations may be complex

where there is a high density of signals eg at interchanges, elevated roads, long cuttings, tunnels or underpasses or where the sequence passes through Police Control Office boundaries.

General Design Considerations

9.9 The location of equipment shall be designed so that adequate safe and easy access is provided for the maintenance of all equipment.

9.10 The potential dangers from vehicle and equipment breakdowns and the difficulties of dealing with emergencies within the confines of a tunnel, together with the problems of access may present the police, tunnel operators and emergency services with severe operational difficulties, all practical and reasonable mitigation measures shall be considered during the design stage.

9.11 An integrated approach shall be used when designing communication systems, and in particular the control centre equipment. The electrical power system shall be designed to supply all of the control centre communications system requirements. As the systems carry emergency service requirements they should be provided with battery back up sufficient to ensure as uninterrupted supply.

9.12 Duplication of equipment at the control centre shall be considered. Typically, equipment working in main and standby modes is often necessary to ensure operational availability.

9.13 Of particular importance is the integration of systems so that the organisation responsible for day to day operation of the tunnel is provided with a clear indication of the overall status of the tunnel operations. A custom-built layout is normally provided for the traffic control room in the TCC, incorporating control desks with facilities for dealing with emergency calls, alarms and radio calls, and for viewing traffic in and around the tunnel by television monitors linked to the CCTV system. Control desk facilities will also include for activated alarm identification of which emergency telephone is calling, selection of CCTV camera input for display on a particular monitor and for setting up variable message signs etc.

9.14 The layout and provision of equipment for the organisation responsible for the various activities are important factors to be agreed with the organisations concerned.

9.15 The communications equipment room(s) at the TMC and the TCC (separate from the control room) shall be laid out so that maintenance staff can readily access the equipment for routine maintenance and repair work. All cables shall be terminated on a clearly labelled distribution frame with unrestricted access. Space within the communication equipment room shall be allocated for spares, system documentation, and maintenance terminals if required.

9.16 Full consideration shall be given to the equipment room environmental conditions eg temperature, humidity and dust exclusion, to ensure correct equipment performance. Equipment room access security is also required.

9.17 For some tunnels, it may be necessary to provide additional equipment rooms and/or out stationed equipment cubicles. These should preferably be located outside of the tunnel. Similar design criteria are required for these but the more hostile and vulnerable environment for any cubicles near or within tunnels shall be taken into account.

9.18 Where VMS, EMS and other signalling is unavoidably required within a tunnel then provision shall be made for cabinets to house the signalling equipment, these can conveniently be located at an Emergency Point. For such cabinets a local power supply isolation facility for maintenance purposes shall be provided. Adequate facilities shall be made for all necessary power and communications cabling to the signs and signals, from power supply points and the main communication cabinets.

9.19 Mechanical and electrical failure mode effects analysis is required to the relevant British and/or European Standards. The analysis shall include all aspects of signal, face interlocking, signal interlocking and signal driver interactions.

Cable Routes

9.20 In relatively short tunnels (less than 1km in length) cable may be run straight through ducts to the equipment within the tunnel (telephone, camera, etc). In longer tunnels, cable is usually run to a distribution box, where the cable is terminated and distributed to the adjacent area. Space shall be allocated for such a box, which shall be readily accessible for maintenance purposes.

9.21 Provision shall be made for routeing the multi-pair copper, fibre optic and associated communications power cables through or round a tunnel.

Communications cables shall not be installed within 0.5m of electricity supply cables, other than those supply cables associated solely with the communications system.

Facilities in Tunnels

9.22 The following facilities are available for deployment, according to the tunnel classification described in Chapter 3:

Telephones - General

9.23 In an emergency such as a vehicle breakdown or fire, tunnel users need to be provided with facilities to communicate readily with the appropriate authority.

9.24 Telephones located at emergency points shall be installed in such a manner that they can be readily accessed and used in safety away from the tunnel traffic.

9.25 Emergency telephone installations shall consist of the following items, to be confirmed by the TDSCG:

- i. Emergency telephone
- ii. Maintenance telephone
- iii. Smoke control telephone.

9.26 In addition, telephones shall be provided at TDSCG agreed locations, such as entrances/exits of the tunnel and adjacent laybys or locations where large or hazardous loads require special attention such as inspection or escort.

9.27 All line levels of the telephones shall be compliant with NMCS.

9.28 Telephones shall be installed at a height of 1.1m to the handset centre line, above finished ground level.

9.29 Heavy traffic vibrations, high ambient noise levels, traffic fumes, as well as the nature of use, dictate the standards to which the telephones and their installation need to conform. See Chapter 2.

9.30 The adverse effects of the very high noise levels in the tunnel on the use of telephones shall be minimised by:

- i. Dynamic side tone switching to provide a controlled level of feedback from the mouth to the ear of the user

- ii. Separate send and receive circuits to optimise the speech paths to and from the TCC/TSB/TMC. Use of two or four wire circuits to be confirmed.

- iii. A telephone specially designed to reduce the effects of background noise eg with a noise cancelling microphone, rather than use of acoustic hoods.

Emergency Telephones

9.31 The telephones may be connected to NMCS, (which is to be approved on behalf of the Secretary of State) to provide direct links to the TCC. Telephones shall utilise self diagnostic equipment with automatic fault alarms. Lifting a handset shall raise an automatic alarm at the TCC and initiate a local flashing alarm at the point of use.

9.32 Emergency telephones shall be able to receive calls from the TCC which, in addition to the normal audible ringing signal, shall initiate a local flashing alarm of the same cadence.

9.33 When the telephones are connected to the NMCS, the responders for interface equipment shall be located at both ends of the tunnel, on opposite carriageways, or within service buildings, unless otherwise agreed.

9.34 If more than two responders are required to service all the telephones within the tunnel and approaches then they shall be located at both ends of the tunnel so that an equal number of telephones is served from each location/responder.

9.35 To provide increased security of coverage within tunnels, alternate telephones shall be served from responders at different locations. Adjacent telephones shall not be served from responders at the same location or served from the same cable.

9.36 Adequate signs within the tunnel shall be provided to allow road users in difficulties to locate an emergency telephone readily. Each telephone and associated equipment shall be clearly identified with suitably designed signboards clearly signalling that such telephones are intended for the use of the road user, and the locational reference number of the telephone.

Maintenance Telephones

9.37 Where required, the maintenance telephones (Engineer's or Service) shall be part of the emergency point installations and shall be connected to a Service Telephone Network (STN).

9.38 The STN shall link all plant rooms and other operational locations relevant to the operation and maintenance of the tunnel and its various support facilities.

9.39 Such telephones may take the form of full telephones or jack socket connections.

Smoke Control Telephones

9.40 Where required in addition to the maintenance telephones, the smoke control telephones shall be part of the emergency point installations and shall connect the user directly to those in control of the ventilation as identified and agreed by the TDSCG.

Closed Circuit Television (CCTV)

9.41 Where CCTV is to be provided, cameras shall be installed inside the tunnel, outside of each portal and on the approaches/exits so as to provide as far as is practical total, unobscured coverage.

9.42 The Design Organisation shall ensure that the whole of both tunnel bores and the approach roads, to the first upstream and downstream junctions or diversion points, can be viewed from the TCC/TSB/TMC, as required. Cameras shall be positioned to ensure that the maximum effective coverage is achieved with a minimum number of cameras.

9.43 It is appreciated that factors such as alignment, obstructions caused by tunnel equipment, etc may prevent 100% coverage.

9.44 Cameras inside the tunnel shall be cornice mounted, those outside the tunnel shall be installed on masts or gantries.

9.45 Potential invasion of privacy shall be mitigated for at all cameras sites and precautions taken by electronic or physical blanking out, or the restriction of lens magnification.

9.46 All cameras shall be provided with pan, tilt and zoom (PTZ), screen wipers, washer bottles and weatherproof housings, as necessary.

9.47 To avoid damaging and safety monitoring hazard effects from headlight dazzle, to reduce privacy invasion and to make use of red brake-lights as an additional visual traffic problem alarm, fixed position cameras shall not face the oncoming traffic. Image processing, if used, also requires cameras to face to the rear of traffic.

9.48 Provision shall be made for all necessary local camera cabling and cable junction boxes, which can conveniently be housed at emergency points.

9.49 The design shall identify requirements for interfaces with the traffic control system, where appropriate (ie. NMCS2).

9.50 CCTV controllers shall be located at intervals within tunnels, and in positions that do not impede the access ways.

9.51 Consideration shall be given to providing monitors that can sequentially scan the cameras on a regular basis. The technique is well proven and is satisfactory for routine operations.

CCTV Alert

9.52 CCTV Alert is a technique whereby traffic flow data is collected by means of vehicle detectors and analyzed using the HIOCC (High Incident Occupancy) algorithm. A pre-selected camera (or cameras) is focused on the area which caused the HIOCC threshold to be exceeded. Perturbations in traffic flow, possibly caused by a stranded vehicle, are then quickly brought to the attention of the TCC. The need for CCTV Alert shall be discussed by the TDSCG and if so recommended shall be considered by the Overseeing Organisation for confirmation of its use.

9.53 The recommended concentration of CCTV cameras in tunnels is such that it may be uneconomic to provide video transmission circuits back to the TCC/TSB/TMC for all. Additionally, TCC accommodation requirements would normally prohibit the provision of a monitor permanently allocated to each camera.

9.54 When CCTV Alert is provided, the fire point and cross connection passage door alarms shall be linked into the CCTV Alert system in order to focus a camera on the area where the alarm originated or where the pedestrians may be situated. This enables the TCC to quickly assess the situation and take any necessary safety measures required.

Fixed Signs, Variable Message Signs and Signals

9.55 Signs and signals used for traffic control shall meet the requirements of the Traffic Signs Regulations and General Directions and approval on behalf of the Secretary of State. Examples of tunnel signing are given in Figures 9.1 and 9.2.

9.56 Responsibilities/approval for signing/signalling in England (items i. to iv.) are as follows:

- i. Static signs - Driver Information and Traffic Management (DITM), Department of Environment, Transport and the Regions
- ii. Variable Message (EMS & FT(fixed text)MS) - DITM and Highways Agency
- iii. Signalling - Highways Agency (who will liaise with DITM)
- iv. Sign lighting (if required) - Highways Agency
- v. Approval may also be granted by the Overseeing Organisations, elsewhere.

9.57 Conventional motorway and trunk road communication systems, such as NMCS2, are not designed nor maintained as Safety Critical or Safety Related systems. Safety Critical and Safety Related systems shall be partitioned such that the Safety Critical or Safety Related element is clearly separated from the NMCS system. Partitioning systems in this way should also minimise costs.

Emergency Exit Signs

9.58 Signing of escape routes for road users in the event of an emergency shall be provided. At each emergency point within the tunnel it is desirable to include the distance to the nearest emergency exit in each direction.

9.59 On uncontrolled escape routes permanently illuminated signs shall be used.

9.60 On controlled escape routes Variable Message Signs or signs only legible when illuminated shall be used. These signs shall have a facility for switch on only when it has been verified that the route is safe to be used.

9.61 Special consideration shall be given to the maintenance and operation of Safety Critical Systems to ensure the safety of road users and personnel is maintained throughout the life of the system.

Variable Message Signing

9.62 Variable Message Signs (VMS) consist of either Fixed Text Message Signs (FTMS) or Enhanced Message Signs (EMS). Both of these sign types may be used to provide traffic management instructions for predictable situations which affect traffic flow and to sign diversionary routes. For example, VMS displays

may be appropriate where it is necessary to regulate traffic in the event of routine maintenance or emergency tunnel closures.

9.63 FTMSs and EMSs may also be used to enhance signalling during emergencies. Such VMS shall be controlled and monitored from the TCC.

9.64 Where variable message signs and signals are used for maintenance procedures, FTMS type signs shall be employed, possibly in conjunction with EMS type signs.

9.65 When considering VMS sites, the visual criteria for siting normal signs shall be applied and they shall comply with the relevant provisions of the Traffic Signs Regulations.

9.66 Where VMS units are required to have flashing amber lanterns, they shall be synchronised between all VMS units viewable from one location, and with any flashing lanterns associated with motorway matrix type signals viewable, within 100m, at the same time

9.67 A facility for local manual control of VMSs shall be provided, but with suitable safeguards to ensure avoidance of the potential for displays to conflict with the remotely controlled system requirements.

Portal/Lane Control Signals

9.68 Considerations shall be given to providing static advice signs describing what portal/lane control signs mean, as detailed in the Traffic Signs Regulations.

9.69 Signals to be sited in the tunnel shall be located centrally over each lane. Care shall be taken to ensure signal visibility and that signals and equipment do not encroach within the traffic gauge.

9.70 In circumstances where portal lane control signals cannot be mounted centrally above the running lanes care shall be exercised to ensure that there is an unambiguous relationship between the displayed aspects and the lanes they apply to.

9.71 Matrix type signals should generally be provided (details are given in Schedule 6 of the Traffic Signs Regulations).

9.72 Portal/lane controls signals, capable of displaying lane closed cross (red), lane open arrow (green) and blank (wig-wag), shall be provided where it is necessary to separately control traffic in each running lane and to employ contraflow working during maintenance etc, as these type of signs can be safety interlocked.

9.73 If contraflow is to be operated, then signals shall be mounted at the entrance and exit of each bore along with loop detectors. Lane control signals within the tunnel should be mounted back to back.

9.74 Provisions for signs and signals shall be according to the type of tunnel:

- i. All tunnels shall be equipped with portal/lane controls signals to enforce closures. Supporting VMS/EMS may be provided at the tunnel portals to provide the road user with information explaining the reason for any closure eg TUNNEL CLOSED with relevant text ACCIDENT, FIRE, TRAFFIC FUMES etc
- ii. For normal traffic conditions, two way and all dual carriageway and motorway tunnels shall have lane control signals mounted centrally above the running lanes within the tunnel
- iii. For dual carriageway and motorway tunnels gantry mounted signals shall be provided upstream of the tunnel, before the last divergence point, to warn that the tunnel is restricted or closed (ie the portal signals are in use) and provide the road user with the opportunity to use a signed alternative route.
- iv. Single carriageway tunnels shall be provided with upstream (lead in) signals to warn motorists as (iii).

9.75 For two way tunnels, care shall be taken in signing to discourage traffic from entering the tunnel on the right hand side of the road.

Display Requirements

9.76 Consideration shall be given to provide for the alternative of not displaying the green arrow, on portal/lane control signals, but showing blank instead.

Face Interlocking

9.77 All VMS signs and signals potentially capable of displaying conflicting information shall be interlocked by hardware, software or a combination of both.

9.78 Portal/lane control signals shall be hardware interlocked on site so as to ensure that lane open arrows cannot be displayed simultaneously on both forward and rearward faces.

Motorway Matrix Signals

9.79 Motorway tunnels which require overhead lane signalling to be used regularly for contraflow, or where the approaches to tunnels will be subject to restricted access shall be provided with motorway matrix signals in place of the wig-wag type signal.

9.80 The normal rules for the provision of signals on motorways apply to tunnels and their approach roads. Because alignments of tunnels and their approach roads may differ from open motorways, the Design Organisation shall ensure that the indicator legends and their flashing lanterns are legible at 300m and 500m, respectively. Signal siting shall also provide continuous visibility over a 500m range.

MIDAS

9.81 For motorway tunnels Motorway Incident Detection and Automatic Signal setting (MIDAS) may be required. The system processes data from vehicle detectors and applies HIOCC algorithms to automatically set speed restriction signals on motorway matrix signs. MIDAS may also be used to automatically display messages on VMS signs.

9.82 MIDAS shall be provided in the tunnel and on the approach roads as far as the first upstream junction or diversion point or as far as queues may be expected to form, with the intention of protecting, from collision, vehicles in the tunnel, at the entrance/exit of the tunnel and the rear end of traffic queues.

9.83 The Overseeing Organisation shall be consulted regarding the deployment of MIDAS at non-motorway tunnels.

Traffic Monitoring

Automatic Traffic Monitoring Vehicle Detection

9.84 A system shall be provided to detect vehicles stopped in a tunnel so that CCTV camera(s) can automatically view that area before an emergency telephone conversation.

9.85 Vehicle detection loops may be provided within the tunnel and beyond the exit of the tunnel for 100m. Spacing of the loops is usually at 50m intervals. All weather laser scanner types perform similar functions and being gantry mounted do not involve disruptions to the carriageway surface. Both systems are able to be used within vehicle classification systems at toll booths etc.

9.86 Above road detection systems (infra red, microwave and CCTV image processing) may be used.

Vehicle Counting

9.87 Vehicle counting shall be achieved by the installation of (2N-2) vehicle detection loop arrays in the carriageway where N = Number of lanes including any hard shoulder.

Vehicle Measuring

9.88 The need for provision of vehicle measuring equipment will be decided by the Overseeing Organisation.

9.89 Measuring equipment shall be capable of providing:

- i. A continuous count of the number of vehicles per hour in each lane in each of the following two categories:
 - a) HGVs
 - b) Other vehicles
- ii. A continuous count of the total number of vehicles per hour in each direction, classified in speed bands.

Traffic Census Equipment

9.90 The need for provision of traffic census equipment will be decided by the Overseeing Organisation. The location and numbers of traffic census sites to be provided shall be in accordance with the requirements of the Overseeing Organisation.

Overheight Vehicle Detection

9.91 Provision of over height vehicle detection is only required for tunnels whose headroom clearances do not meet TD 27 (DMRB 6.1.2) and for limited facility tunnels.

Toll Collection

9.92 The need for provision of toll collection equipment will be decided by the Overseeing Organisation.

Radio Rebroadcast Systems

9.93 Tunnels shall be provided with a means of maintaining radio communication with emergency

vehicles, emergency personnel and maintenance staff. Consideration may be given to digital trunked radio systems to provide data as well as speech facilities, where justified.

System Requirements

9.94 All radio transmission systems within a tunnel require approval of the Department of Trade and Industry or, in the case of Home Office approved emergency services, shall comply with Home Office Regulations.

9.95 Radio systems to be provided in new tunnels shall be given priority in the order of Police, Fire Brigade, Ambulance Service, Tunnel Operating Authority and other services.

9.96 All radio operating Authorities are required to obtain their own licences for the use of the equipment.

9.97 Care shall be taken in the siting of any form of aerial within a tunnel to ensure good radio coverage and avoid any interference with, or from, any other radio or tunnel equipment provided. Where more than one radiating cable is to be installed into one tunnel bore, then provision shall be made for eliminating or minimising any interference between the cables, or any other susceptible devices. Radio cable lengths into the tunnel and to any outside aerials shall be minimised.

9.98 Where 'off air' rebroadcasting systems are to be used, provision shall be made for external aerials in locations that permit effective communication. Active equipment shall be installed in a position that maximises its ability to receive radio signals 'off air', and provides a clear path and minimum distance for the feeder cable connecting it with the radiating cable.

9.99 At both the design and commissioning stages, coverage performance shall be considered, to minimise any dual path propagation effects, from normal 'off air' signals and signals from the radiating cable.

9.100 Any Overseeing Organisation contribution to the provision of the radio rebroadcast facilities for the emergency services and Tunnel Operating Authority shall be agreed at an early stage of the tunnel design.

System Performance

9.101 The performance of the radio rebroadcast equipment shall provide clear and intelligible reception to the Police, Fire, Ambulance, Tunnel Operating Authorities, and Breakdown/Recovery Services mobiles or hand portable receivers.

9.102 For existing tunnels, it may be required to extend coverage of emergency and maintenance services throughout the tunnel. A general review may be found in TRRL Contractor Report 41, 'Planning and design considerations for Road Tunnels: The Influence of Operation and Maintenance', in particular Table 10.

Police

9.103 Normally the Overseeing Organisation will provide to the Police the radiating facility, some space for a rack of electronic equipment, a power supply and a site for an external antenna. The Police, either directly or through the Home Office, shall provide, install and maintain the electronics. Frequencies used are in the UHF and VHF bands and the Home Office shall be consulted for details.

Fire Brigade

9.104 The same situation as for the Police can apply, although the Overseeing Organisation may provide the entire package as the Fire Brigade take the view that the Overseeing Organisation should provide and fund any equipment necessary for fire protection.

Ambulance Service

9.105 Normally the Overseeing Organisation will provide all equipment to facilitate one VHF channel throughout the tunnel, ie vehicle to base. In addition, the Ambulance Service will provide a link between medical emergency teams working at the scene of an incident and the hospitals who would receive any injured.

Tunnel Operating Authority

9.106 Provision by the Overseeing Organisation of one speech channel for use by the Tunnel Operating Authority in their normal work and when assisting the emergency services can normally be justified.

Broadcasting Radio and Mobile Telephones

9.107 When a road user enters a tunnel, the car radio and mobile phone will cease to function effectively. An additional re-broadcast system could be installed by the service provider to maintain continuity of their service. Normally the Overseeing Organisation will not permit the use of a road tunnel by third parties who may wish to have their networks carried through the tunnel. A re-broadcast system may be acceptable provided it does not interfere with, or degrade, the emergency and operational facilities described. The rebroadcasting company would then be required to finance its installation and maintenance. See Chapter 2.

9.108 The Overseeing Organisation shall be consulted regarding the issuing of any licences to the broadcasting companies for any service provision in a road tunnel.

9.109 Any arrangements regarding access for maintenance shall be agreed with the Overseeing Organisation at an early stage of design.

Communications Infrastructure and Cabling

9.110 Communications infrastructure used in motorway tunnels shall conform, as closely as possible, to the Standards and Specifications for NMCS.

9.111 Communications infrastructure used in non-motorway tunnels may be to a lower level of provision but shall use components which conform to Specifications for NMCS.

9.112 Where the facilities provided in a non-motorway tunnel are monitored and/or controlled from a motorway police control office, the communications infrastructure shall comply with Standards and Specifications for NMCS.

9.113 Extra capacity, as required by the Overseeing Organisation, for the main communications cables shall be provided to allow for future expansion.

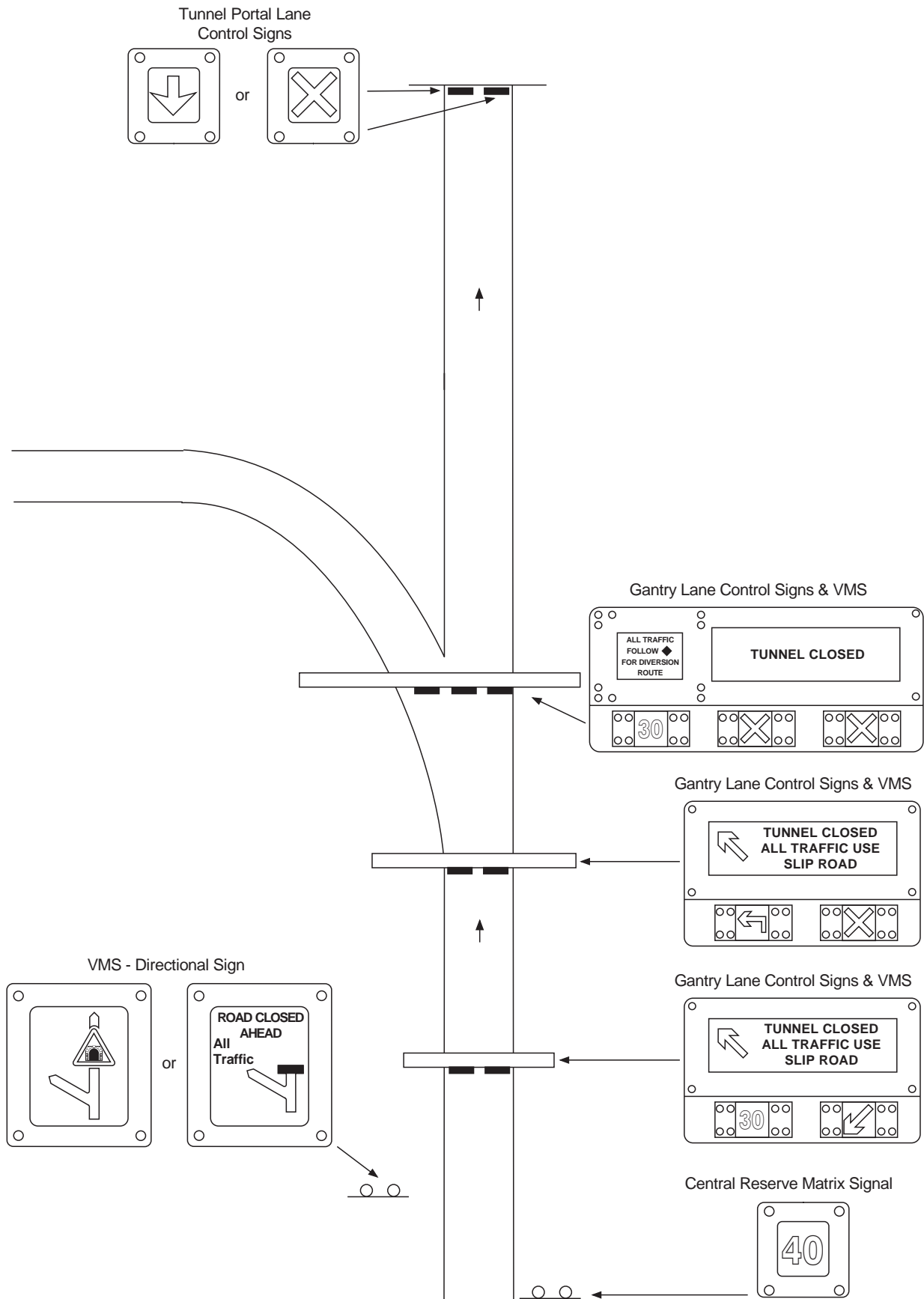

Figure 9.1 Example of a Signing Scheme for a Dual 2 Lane High Speed Rural Road

10. PLANT MONITORING AND CONTROL

General

10.1 Tunnel lighting, ventilation, drainage, security systems etc benefit from programmable logic controller (PLC) based supervisory control and data acquisition (SCADA) facilities which process information received from instrumentation located in or close to the tunnel and determine the optimum mode of operation. Correct programming will ensure that the specified performance requirements and safety criteria are met, whilst avoiding unnecessary use of equipment and consequent wastage of energy etc. Under normal circumstances operation will be fully automatic, with a facility for manual override by the Tunnel Operating Authority (TOA) operator in emergencies or for maintenance. Figures 10.1, 10.2 and 10.3 show typical systems and networks. Figure 10.3 is based on NMCS2 (National Motorway Communication System 2) system architecture.

10.2 To enable the operator to be aware of any failures of plant or equipment and to determine the extent of such problems, the status, consumption and performance of principal items of mechanical and electrical plant is continuously monitored. Alarm signals are generated by certain designated events and upon failure of individual items of plant or complete systems and are graded according to the urgency of response required. Monitoring of performance, plant condition and energy consumption allows the operator to predict maintenance requirements and future operating costs.

10.3 Operator terminals to receive the output data and signals may be provided locally at the tunnel, and at remote locations via suitable data links. Terminals may be programmed for mimic displays to provide complete or partial control and monitoring facilities, with the opportunity to cover a number of tunnels from a single location. Interfaces with other systems, eg CCTV or the Tunnel Traffic Controller (TTC), may be provided to provide additional inputs and outputs for control of plant and to initiate automatic closure of the tunnel under certain emergency conditions.

10.4 The TTC is closely linked to the SCADA system and has the capability to interrogate the SCADA system for information relevant to its traffic control function. As a result of traffic conditions, the TTC can make requests for operation of plant eg increase lighting, switch on fans etc through the SCADA system. An over-ride may be necessary eg to initiate emergency procedures.

System Architecture

10.5 For the automatic monitoring and control of the tunnel environment, a typical system should consist of the following elements:

- i. Central SCADA monitoring equipment, consisting of dual processors (on-line and hot standby), together with watchdog link, status indicator panel, interface equipment and supporting hardware. A service engineer's terminal comprising VDUs (CRT or touch screen type), keyboards, mice and printer shall be provided, adjacent to the central processor, for maintenance and on-line testing purposes. Two VDU and keyboard sets allow simultaneous viewing of system overview and detail pages. SCADA software shall provide the required degree of supervision and control whilst maintaining a high degree of clarity and user friendliness.
- ii. One or more local or remote terminals for use by TOA and Traffic Control Centre (TCC) staff, located as determined by operational requirements. Each terminal shall be equipped to receive alarm and alert messages and to provide monitoring and control facilities as appropriate. It is normal for one such terminal to be located at the Tunnel Services Building for use during maintenance activities and in emergencies, with additional remote terminals at the TOA headquarters and the TCC. These terminals are commonly based on a PC with keyboard, mouse and printers.
- iii. Two printers, as follows:
 - a. An event log printer to provide a hard copy of all events and commands issued, capable of use as a legal record if required
 - b. A service engineer's printer for producing logs and reports as required by maintenance staff.
- iv. PLC based outstations at strategic locations throughout the tunnel installations, linked to each other and to the central processor or monitoring equipment. Outstations will receive environmental and performance data from

instrumentation and monitoring equipment and generate control signals for switching lighting, ventilation fans, drainage pumps etc, as well as alarm and event data. Algorithms for lighting and ventilation etc control will generally be programmed into the appropriate PLC outstations, so that only data relating to alarm and monitoring signals and commands for updating set points or for overriding automatic controls need to pass between the outstations and the central processors.

- v. Instrumentation for control of ventilation, positioned at suitable points within the tunnel to measure tunnel air velocity, external wind speed and direction, concentrations of carbon monoxide, nitrogen dioxide (if required) and obscuration. See Chapter 5.
- vi. Suitably mounted photometers to monitor light conditions at the tunnel portals and threshold zones. See Chapter 6.
- vii. Water level sensors, oxygen depletion and hydrocarbon sensors for control of drainage pumping plant.
- viii. Door switches and similar devices for status information and alarm purposes.

Operational Aspects

10.6 To prevent system faults from causing a deterioration of the monitoring functionality, the system shall be designed with a high degree of security or redundancy. Hot standby with auto-changeover systems are required at unmanned tunnels and may also be appropriate when tunnels are manned.

10.7 Careful consideration shall be given to the effects of fire or power failure on the security of the system and their mitigation eg the manual discharge of foam systems or the switching of standby pumps. It is important to undertake hazard analysis and risk assessments in line with the operating procedures adopted.

10.8 The design of the system software and firmware shall only permit off line software amendments, but shall allow control thresholds for plant and equipment to be adjusted on line. Password protection shall be provided to restrict access to these facilities.

10.9 Full system documentation including Operating and Maintenance manuals shall be provided. See Chapter 13.

Environment, Design Life

10.10 All equipment supplied shall be fit for purpose, built to withstand the rigours of the specific tunnel environment and shall comply with all relevant Standards. All components shall have a design life of at least ten years and shall be compatible with any associated electrical or mechanical plant.

Health and Safety

10.11 Safety requirements for all programmable electronic systems in safety critical applications must be satisfied. Any non-compliance shall be brought to the attention of the Design Organisation for resolution.

System Safety

10.12 All systems and control items shall be designed such that any failure in the instrumentation or control system shall cause all associated plant and equipment to go into, or remain in, a safe state.

10.13 Safety of any systems shall be agreed with the TOA.

10.14 All equipment located within any hazardous area shall be suitable to be certified as intrinsically safe or explosion proof by the appropriate authorities and be clearly labelled as such.

Uninterruptible Power Supply

10.15 An Uninterruptible Power Supply (UPS) shall be provided for PLCs and the SCADA monitor, to maintain monitoring of the plant when the main power supply fails. Any associated field instruments that are required in monitoring the plant may also be connected to the UPS. See Chapter 11.

10.16 The UPS shall provide the SCADA monitor and its peripheral equipment with electrical power of sufficient quality to prevent malfunctions from voltage transients and other mains borne disturbances. Power failures shall be logged as an alarm condition and immediately reported on the SCADA monitor.

Plant Monitoring

10.17 To ensure that an appropriate response is made to every fault or emergency situation it is important that the TOA has access to the operational status of all principal items of tunnel equipment at all times and is alerted to any circumstances requiring speedy action.

10.18 Typical parameters for monitoring include:

- i. Plant status, eg RUNNING/STOPPED/OUT OF SERVICE/FAULT
- ii. Operating state, eg HIGH/LOW, OPEN/CLOSED
- iii. Hours run, energy consumed
- iv. Control availability, eg LOCAL/REMOTE/OFF/AUTOMATIC
- v. Lighting and ventilation levels.

10.19 Digital and analogue monitoring circuits shall be independent of plant control or power circuits, with volt-free on-off or changeover contacts being provided on the equipment as appropriate for interfaces with PLCs. Analogue circuits shall be suitable for 4 to 20mA operation. Where necessary, safety isolation shall be provided, eg by the use of optical couplers, or equivalent. Optical couplers allow different circuits to be connected together but to remain isolated in operation.

Alarm Classification

10.20 Depending on the immediacy of the action required, alarm signals from the monitoring systems will usually be classified as follows:

- i. Alarm signals classed as 'URGENT' include all events or circumstances which involve an actual or potential hazard requiring immediate action. They may also include those which may lead to severe disruption or which indicate a breach of security. These alarms are usually presented audibly and visually.
- ii. Alarms classed as 'ALERT' do not require immediate action but will need to be assessed to establish when investigative or remedial action will need to be taken. Further sub-classification may be desirable, eg to separate items which can be left for a week from those which should be attended to the next day,

- iii. 'RECORD' alarms include such things as plant switching events and the entry and exit of personnel attending the Services Building. Although these require no action, they provide an historical record useful for fault investigation.

10.21 Software shall allow faults and alarms received to be acknowledged in any order. This allows the TOA to prioritise and quicken any response. All fault, alarm and event messages received from the monitoring equipment shall be stored magnetically for future reference and analysis. Urgent messages shall be printed on the system printer.

10.22 The system software shall allow acknowledgement of faults in the order received, to enable the TOA to decide more easily on the order of priority.

10.23 Procedures for handling, storage and down-loading of fault, alarm and event data shall be determined according to local requirements. Long term storage of data should be kept to a minimum. A suitable software search engine shall be provided to assist in assessment and analysis of fault records.

Plant Control

10.24 Except under emergency and maintenance conditions, the operation of the plant shall normally be controlled automatically by the PLC-based systems receiving control signals from the various monitors and detectors in the tunnel.

10.25 By use of information derived from sensors and monitors and other data sources automatic control of the following shall be provided:

- i. Lighting levels in the tunnel - switching on and off successive stages of tunnel lighting to obtain the correct graduation of light intensity. See Chapter 6.
- ii. Tunnel ventilation (where required) - control of the speed or number of fans in operation and the directions of air flow in the tunnel to supply fresh air, disperse exhaust fumes and any fire smoke to maintain a safe and acceptable air quality in all parts of the tunnel. See section on SCADA and Chapter 5.
- iii. Pumping (where required) - because pumping stations are usually localised, control systems would normally serve individual sumps eg to switch on pumps when the water level in the

- tunnel sumps exceeds a preset limit. Connections to the SCADA system shall be for monitoring or override purposes only. See Chapter 7.
- iv. Standby or backup equipment - in most cases, local control systems will automatically detect failures of duty plant and switch to standby or backup facilities. Connections to the SCADA system shall be for monitoring or override purposes only.

Programmable Logic Controllers (PLC's)

10.26 The key functions of the PLC are:

- i. Control of plant.
- ii. Plant status monitoring (including alarms).
- iii. Operator interface.

10.27 PLCs shall directly handle all inputs (eg equipment status information, alarms, environmental data.) and all control outputs. They shall carry out all control algorithms, sequence control functions and data gathering. It shall not be possible for the SCADA monitor to control plant and equipment directly.

10.28 PLCs shall continuously monitor their own operation and report faults to the operator. All items of plant affected by a fault condition shall be controlled to move to a safe condition and any further change inhibited until the fault has been cleared or an override command is issued by an operator.

10.29 Each PLC shall have the following operational features:

- i. Self-check on power-up of the PLC. On successful completion, the PLC will revert to the fully automatic mode.
- ii. Automatic operation. This is the normal operating state under which all PLCs and links to the SCADA monitor will be active. In the event of failure of any communications link, all PLCs shall continue functioning independently, using either the latest remote information, or default values as appropriate. The PLC may also be required to store some historical data locally for later transmission to the SCADA system.
- iii. Manual operation, under which selected plant items are placed under local manual control. All such operations shall be the responsibility of the TOA.

- iv. Software editing facilities. Access to these facilities shall not be available to the operator.
- v. Operator interface - each PLC shall be provided with an interface for a portable terminal for use during commissioning, testing, maintenance, program changing and editing.
- vi. A printer shall not be permanently installed to a PLC.
- vii. Safety and security requirements - password protection shall be provided for all non-routine operator instructions.

Location

10.30 Generally, each PLC shall be located close to the associated plant or control item. For convenience, a limited number of non-related alarm sensors eg emergency call point may use a PLC as their interface.

SCADA (Supervisory Control And Data Acquisition) Systems

10.31 All executive and systems software shall be proprietary packages, fully proven for the intended application. A SCADA specification is required which supports both outline and detailed requirements and from which the functional specification can be written. The SCADA system should provide 3 levels of control:

- i. Fully automatic: driven by environmental monitoring and/or traffic level data
- ii. Remote manual over-ride: from tunnel control centre
- iii. Local manual control: in case of SCADA failure or for maintenance or test purposes.

10.32 A SCADA system provides a useful platform for entering, storing and accessing information relating to tunnel events, costs and other relevant data as required by BD53 (DMRB 3.1.6) The SCADA system shall be capable of use for this purpose.

10.33 A primary objective of the SCADA system is to ensure a safe environment for tunnel users under a wide variety of operating conditions. For example, functions for ventilation include:

- i. Operating tunnel plant automatically and efficiently, including the rapid clearance of air pollution

- ii. Providing a continuous plant monitoring facility, with alarms for abnormal conditions
- iii. Providing operators with clear information on tunnel plant status
- iv. Facilitating the manual operation of ventilation plant, under pre-determined conditions, for smoke control in a fire emergency and for maintenance work
- v. Providing an interface to the traffic control system for automatic signal setting in the event of failure of any key plant.

10.34 The SCADA monitor shall be located in a tunnel services building, with facilities for local and remote terminals.

Privileges and Modes

10.35 Privilege levels - there may be a number of user groups with access to common data, but not able to access each others' privileged information. The minimum user groups to be provided for, include:

- i. TOA/Maintaining Agent (Local Authority)
- ii. Term Maintenance Contractor (Service Engineer)
- iii. Police
- iv. TTC.

10.36 System user access levels (in order) to suit operational needs could include:

- i. Monitoring only (operator CANNOT issue commands)
- ii. Control (operator CAN issue commands)
- iii. Configuration/editing/engineering (by Service Engineer)
- iv. Operating system (from maintenance terminal and under off-line, controlled and tested conditions only).

10.37 To prevent unauthorised use if left unattended, access levels at any work station shall automatically revert, in a safe manner, to the lowest level at a predetermined time after the last key stroke entered.

Data Logging, Alarm Reports

10.38 All data logging, alarm reporting etc shall be carried out by a SCADA system capable of producing site specific printed reports, on demand, at the TOA HQ and TCC. The reports shall typically contain the following:

For operation and maintenance:

- i. Daily log of events
- ii. Daily fault log
- iii. Daily log of outstanding faults
- iv. Monthly log of events
- v. Monthly fault log.

For planning and monitoring:

- i. Energy usage
- ii. Plant running hours
- iii. Air quality versus time
- iv. Lighting and fan stages versus time
- v. Weather data (eg wind speed, temperature, daylight illuminance).

10.39 The memory capacity of the system shall be sufficient for storing records of all events over a three month period without loss.

Link from SCADA to Tunnel Traffic Controller (TTC)

10.40 Should it be required, the SCADA system shall assist the TTC in its traffic control and management functions, by making available its plant and environmental data to the TTC. The TTC shall be able to access the SCADA system to obtain whatever data is needed for the requirements of a specific tunnel location.

10.41 The TTC shall also collate traffic flow data. See Chapter 9.

10.42 Data may be available to the operator, via the SCADA system, through the NMCS2 Control Office Base System (COBS) Tunnel Subsystem or via the TTC in its stand alone mode. Where a tunnel is not equipped with an NMCS2 system a TTC shall be used for this purpose.

10.43 It is important to minimise the energy demands of a tunnel and a significant contribution is required through operating any ventilation fans according to traffic flow. Fans shall start to clear vehicle pollution as its concentration begins to rise, thus reducing the need to run fans at full power to clear high concentrations of pollutants.

10.44 Although traffic flow and speed data is not normally available to the SCADA system via the TTC, there could be significant benefits in arranging for the TTC to assist the SCADA system to refine control functioning, for example by early prediction of ventilation needs from traffic data. A case shall be made by the Design Organisation for agreement and confirmation by the Overseeing Organisation.

10.45 TTC shall comply with the requirement of Safety Integrity Level SIL 3 (as defined in International Electrotechnical Committee IEC 16508).

10.46 Communication between the SCADA system and the TTC shall be controlled in an orderly fashion using a proven protocol. The protocol shall ensure all transmissions are received error free and without loss. The preferred protocol is RS 485 Modbus Plus. Message content between systems shall be tightly defined.

Power Supplies to Transmitters

10.47 Power supplies for field-mounted transmitters shall be routed via the appropriate local control panel and any associated PLC. A two-wire system where transmitters receive power from the signal circuit is preferred.

Transmission

10.48 Adequate provision shall be made for the secure and high speed transmission of all necessary data between plant, equipment rooms, control offices, maintenance depots and all other locations associated with the tunnel. The requirement may require duplication of essential equipment and provision of alternative transmission routes.

10.49 Systems shall incorporate modems for long distance data transmission and provide standard data connectors (ports) for data transmission to local storage devices.

10.50 Data transfers shall take place at predetermined intervals and also whenever demanded by the operator.

Inspections

10.51 Daily visual inspections of the general condition of the tunnel and all of its equipment together with the computer records of continuously monitored equipment shall be undertaken to disclose the majority of faults. More detailed tests, inspections and data analysis shall be carried out at regular intervals for diagnostic purposes. See Chapter 14.

10.52 The SCADA system shall be regularly inspected.

10.53 The intervals for detailed examinations depend on the operational circumstances and equipment provisions of a particular tunnel. The SCADA system shall prompt and remind the TOA when such inspections are due.

10.54 Inspection observations shall be recorded in a clear and simple a manner on forms designed for computer encoding into the SCADA system. To assist an inspector in identifying defects and remedial actions, the SCADA system shall present inspection results on a VDU and/or printer in a form which allows ready comparison with past data.

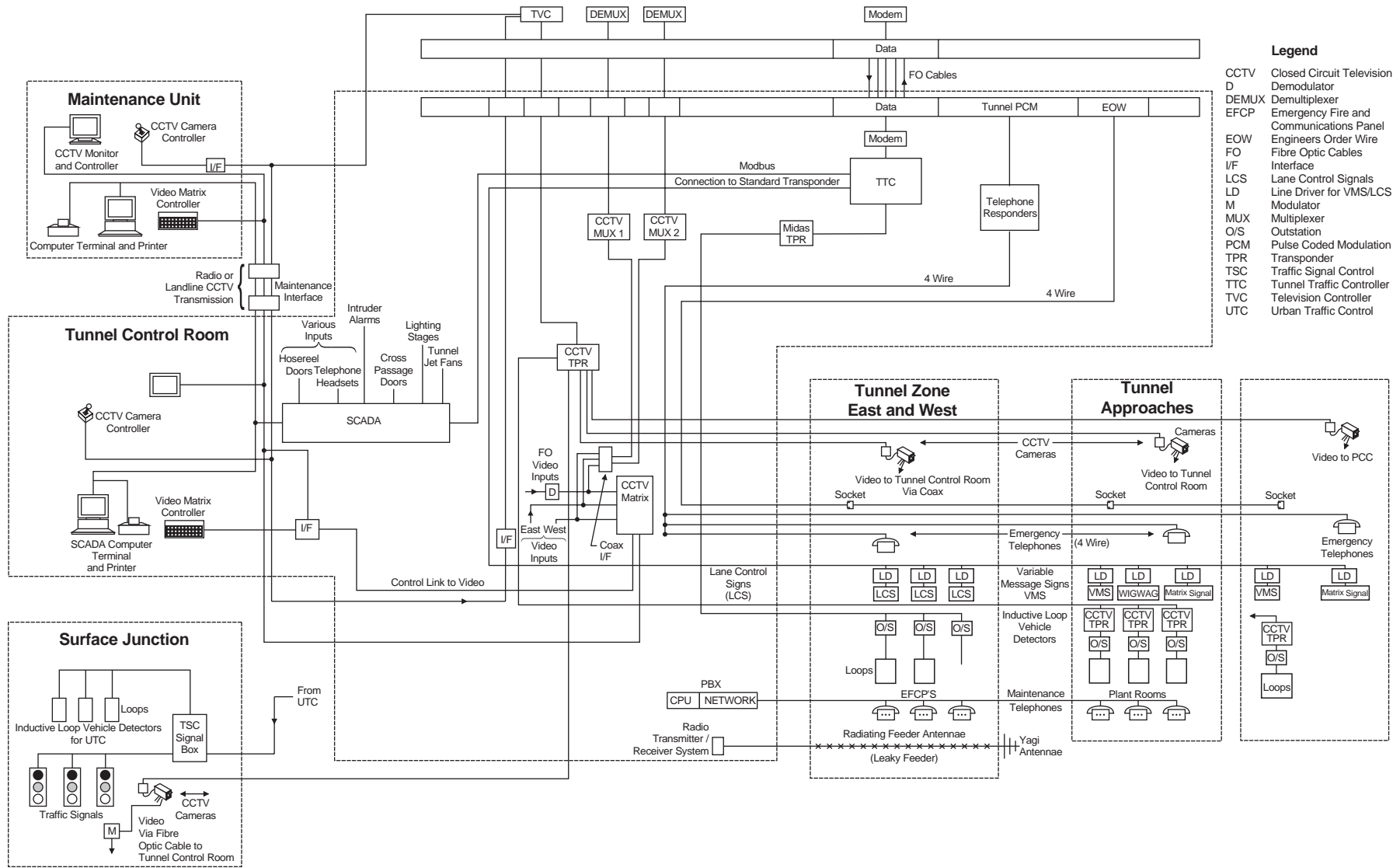

Legend

- CCTV Closed Circuit Television
- D Demodulator
- DEMUX Demultiplexer
- EFCP Emergency Fire and Communications Panel
- EOW Engineers Order Wire
- FO Fibre Optic Cables
- I/F Interface
- LCS Lane Control Signals
- LD Line Driver for VMS/LCS
- M Modulator
- MUX Multiplexer
- O/S Outstation
- PCM Pulse Coded Modulation
- TPR Transponder
- TSC Traffic Signal Control
- TTC Tunnel Traffic Controller
- TVC Television Controller
- UTC Urban Traffic Control

Figure 10.1

Example Tunnel Communications Network

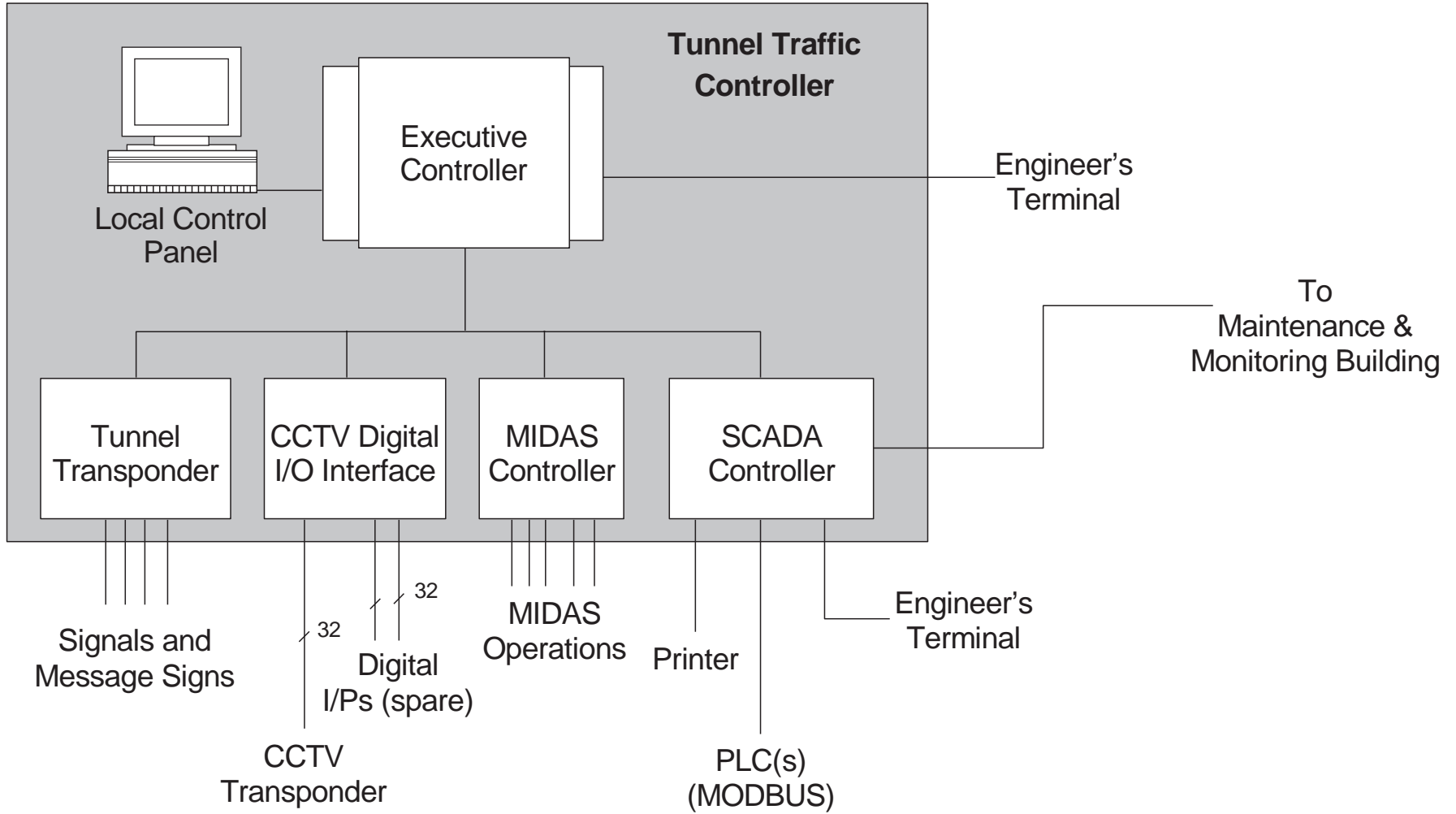

Figure 10.2

LAN Based Subsystems - Standalone System

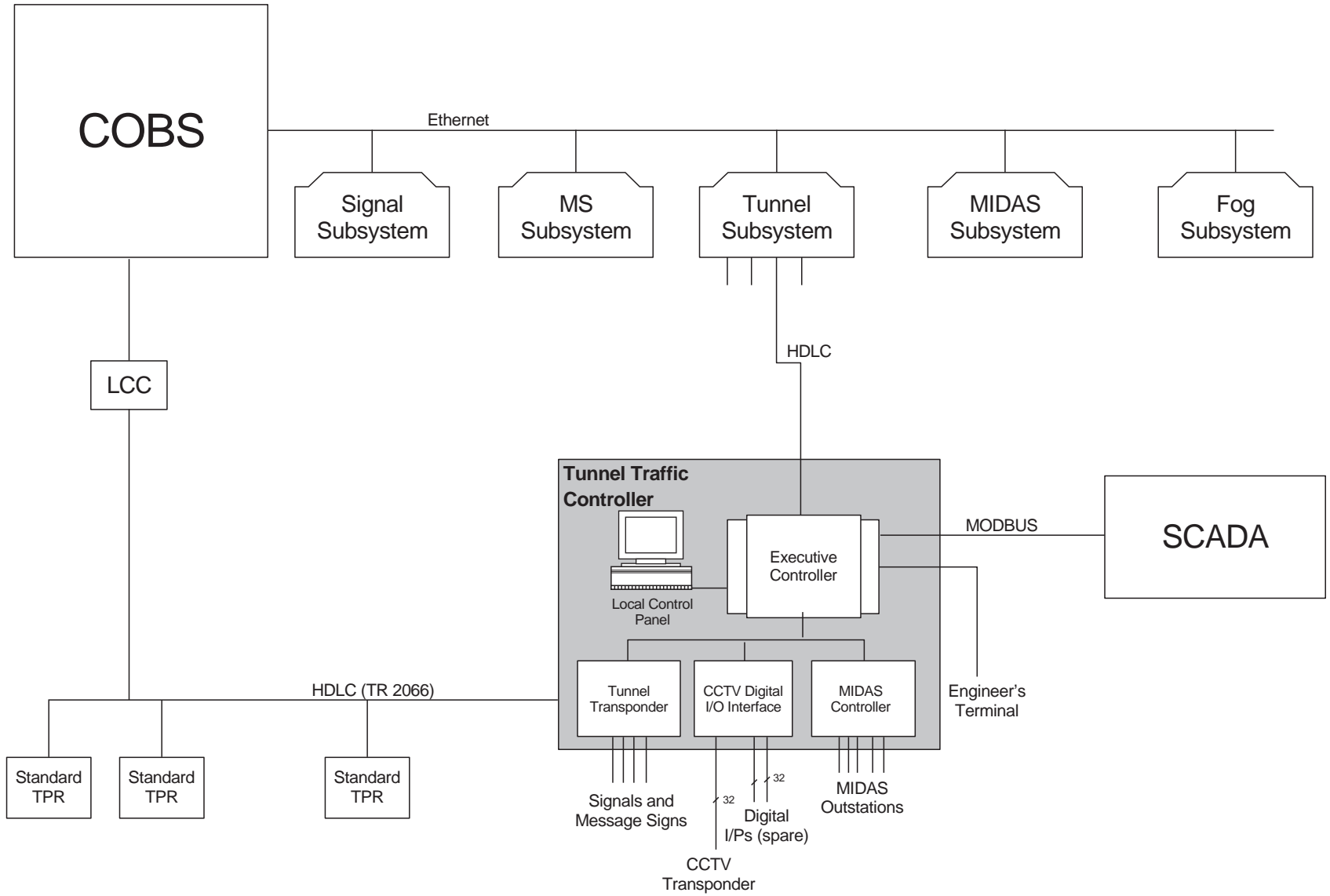

Figure 10.3

LAN Based Subsystems - Full System

11. ELECTRICAL POWER SUPPLY AND DISTRIBUTION

11.1 This Chapter describes the provision to be made for the supply and distribution of electrical power for the tunnel equipment and services installed to provide safe conditions for the full range of operational requirements, including emergencies. Requirements for earthing and circuit breakers are important in reducing the risk of electrical fire.

11.2 Power is normally received at high voltage, typically 11kV, and is distributed to one or more substations along the line of the tunnel, where it is transformed down to 400 volts for final distribution to plant and equipment throughout the tunnel systems, via a low voltage main switchboard, which contains control and protection equipment for the numerous circuits.

11.3 Incoming supplies and key items of equipment such as transformers and main distribution cables are frequently duplicated, and appropriately sized so that if one is out of service, either because of a fault or for maintenance, service can be maintained via the other for as long as necessary.

11.4 To maintain supplies to essential equipment in the event of failure of the incoming supplies, standby power is provided. This may take the form of uninterruptible power supply (UPS) equipment, which uses battery power to maintain supplies without a break to connected equipment for a limited period of time, or one or more diesel powered standby generators which will start automatically when a mains failure is detected and run for as long as fuel is available or until mains power is restored. In the latter case, a limited amount of UPS provision is needed to cover the short period required for the standby generator to start and run up to speed, and also for the possibility of a failure to start. A stand-by generator will not normally be required, but may be necessary eg where there are essential loads, such as pumping, which exceed the practical capacity of the UPS or tunnel closure due to prolonged lighting reduction is not acceptable.

11.5 The provision of duplicate and standby equipment can be very expensive in its own right and also in terms of space requirements. It is important to establish at a very early stage in the tunnel design exactly what level of security is required, and to balance the cost of additional facilities against the consequences of loss of supply eg tunnel closure.

11.6 A wide range of electrical equipment is installed within a tunnel to keep the tunnel safe for road users. The main equipment comprises 11kV and 400V switchgear, transformers, distribution boards, fans, pumps, luminaires and associated equipment supported by stand-by supplies. Most tunnels will use two substations but in long tunnels 3 or 4 sub-stations may be needed for adequate supply distribution.

Supply Requirements

11.7 Requirement for electricity shall be assessed for each main area of demand (lighting, ventilation, pumping and the remainder of the installation), to determine the total connected load in kVA and the likely maximum demand. This will enable the supply capacity and the ratings of the plant (transformers, switchgear and cabling) to be established. Electricity supply organisations shall be consulted at the design stage about the estimated installed load for all tunnel electrical equipment (lighting, pumps, fans etc). Information for discussion shall include sufficient predicted load profiles, plotted against time over typical 24 hour periods and any seasonal variations as well as peak demands during an emergency. This will then allow the most appropriate tariff of energy charges to be determined.

11.8 Maintaining a high power factor is necessary to minimise tariff penalties from the supply authority and to reduce electrical losses. Power factor correction equipment shall be installed, where necessary, to achieve a minimum overall power factor of 0.92.

Tunnel Electricity Supply System

11.9 The following description illustrates the main features of a typical tunnel electricity supply system, with two substations. See Figures 11.1, 11.2 and 11.3.

11.10 Two high voltage (HV) supplies, at 11kV and derived from separate sources, ensure maximum security of the power supplies. The cables associated with these services are separately routed for maximum security of supply. The HV is transformed to 400V and distributed via the low voltage (LV) switchboards to distribution panels mounted in the tunnel walls at road level. Each panel has two compartments, each houses final circuit

distribution equipment fed from one of the two supplies. By this means, power from each supply is separately and evenly distributed throughout a tunnel to supply tunnel lighting jet fans, axial fans in inlet/outlet shafts etc.

11.11 Figure 11.1 shows an arrangement where HV supplies 1 and 2 are provided at opposite ends of a tunnel, Figure 11.2 shows both supplies at one end only and Figure 11.3 is as Figure 11.2 but with provision for standby generation. Cabling associated with Supply A and Supply B should be segregated to achieve maximum security of supply, including during a fire. Change-over connections at HV may be provided, and at LV will be provided, to give the maximum security of supply. For normal operation, circuit breakers 1 and 2 are open giving two independent systems. The loss of a main supply feeder, A for example, shall be sensed and causes the 11kV incoming circuit breaker on side A to open, and circuit breaker 1 to close, restoring a supply to the A side.

11.12 The change-over connection at the 400V side of the transformers, circuit breaker 2, allows for one transformer to be out of commission and isolated, and all circuits to be connected to the functioning transformer. Care shall be taken in the interlocking of the HV circuit breakers and the LV circuit breakers to prevent any paralleling of supplies.

11.13 In the tunnel, luminaire circuits are connected alternately to the three phases of the A and B supplies as shown. Similarly the other electrical loads of the tunnel will be alternately connected to the A and B supplies, as far as is practical.

11.14 For security of essential loads an uninterruptible power supply (UPS) is provided. At some tunnels a standby generator may also be provided, connected to a third section C of the LV switchboard. In such cases the UPS and essential loads can also conveniently be connected to C, see Figure 11.3.

11.15 If the 11kV supplies are provided one at each end of the tunnel (Figure 11.1) then an auxiliary 11kV interconnector cable is required to achieve the same degree of security of supply. In this case, interconnection of the 400V supplies would not usually be undertaken because of the problem of excess cable size, and the UPS and/or stand-by generator would be connected to one side only of the LV supply board.

Security of Supply

11.16 Security of supply is paramount. Primary supplies shall ideally be derived from two

independent sections of the 11kV network which, in turn, should preferably be derived from different points on the National Grid system. Careful consideration shall be given to establish if faults on one section of the system feeding one side can affect the second supply.

11.17 It can be difficult to obtain two truly independent separate supplies. They may be independent up to a point but still be derived from a common 33kV grid substation. Failure of the supply at the 33kV level, eg by damage to overhead lines, could lead to loss of both incoming supplies and this possibility shall be taken into account when assessing standby supply requirements.

11.18 A UPS with a 2 hour capacity will normally be provided for essential loads (as discussed under UPS) and standby generators will not normally be used, see earlier text.

11.19 A whole life costing approach to the provision of standby power is valuable to balance the high costs of installing and maintaining full UPS systems against those of partial UPS with standby generator plant. Standby generators have the potential to be used for peak lopping locally and into the supply network, provided they are designed for the purpose and the necessary additional equipment for control and synchronisation is installed.

11.20 The method and degree of security of supply which can be negotiated with the electricity supplier will considerably affect the HV design.

General: Design and Maintenance

11.21 Electrical equipment to supply and control electrical services in tunnels shall be designed to have a minimum 20 year service life. Its design requires special care and attention to detail to ensure continuity of supply, safe working conditions, performance, proper operating sequences and physical measures to combat a hostile environment.

11.22 The maintenance philosophy to be adopted shall be taken fully into account in the initial design of the whole of the electrical system. The system shall be capable of being safely maintained. Onerous maintenance requirements may be reduced by specifying the most appropriate plant.

11.23 The cable layout and circuitry shall be designed with maintenance in mind and particular attention paid as to how future electrical testing will be carried out and at what frequency. Ease of fault finding in the system

shall also be taken into consideration together with provision for removing and replacement of the installation at the end of its useful life.

11.24 Minimum standards for the design and installation shall be those given in BS 7671: Requirements for Electrical Installations. If the minimum standards included in the Standard are not acceptable and higher standards, or particular alternatives, are required, these shall be defined under the relevant section of the project specification, with reference to other appropriate standards. The requirements of relevant legislation such as EEC Directives and the Electricity at Work Regulations 1989 must be met.

11.25 The tunnel environment is particularly aggressive and the combination of road salt, soot and chemical substances from vehicle exhausts and accumulated acids from tunnel washing detergents can be highly corrosive. Within this environment, equipment such as junction boxes, cable trays and trunking, conduits and accessories, brackets, channels and metal supports, shall, wherever possible, be made of a suitable high grade stainless steel. All fixings, screws, nuts and bolts, washers and studs shall also be of stainless steel of a compatible grade. The grade of stainless steel in all instances shall be chosen for the environmental conditions, see Chapter 2. If carbon steel has to be used, with the prior agreement of the Overseeing Organisation, it shall be galvanised or epoxy painted to a high standard. Mixed metal joints shall be avoided.

11.26 All materials shall be compatible one with another. In those areas outside the tunnel where stainless steel and IP65 enclosures are not required fixing materials, conduit systems including all accessories, cable trays, cable trunking and similar material shall be hot dipped galvanised. There shall be no exposed bare metal surfaces where corrosion can occur.

11.27 All plant, equipment, fittings and any other component of the permanent installation within the tunnel and other areas affected by the tunnel environment shall be protected to IEC Category IP65, or other suitable standard. Water jet velocities shall be stated.

High Voltage (HV) System

11.28 HV systems must only be operated by Authorised Persons (APs) with appropriate training and certification. Not all TOAs have such staff available at all times, and the system design and operating

procedures shall allow for switching operations to be contracted out to others.

HV Distribution

11.29 Each 11kV feeder shall terminate in a substation where the supplies will be metered. The substation may form part of the services building provided for the tunnel. The consumer's 11kV switchboard may be installed in a separate 11kV switchroom within the services building. However, to increase reliability, it is better to negotiate common use of a single 11kV switch room with bus-bar connection between supplier and user. Each switchboard shall comprise two sections, A and B, with a bus-section switch between the two sections. One supply feeder will be connected to each section.

HV Switchgear

11.30 Although other types may be considered, the recommended HV switchgear is the indoor single bus-bar, metal enclosed, compartmented type, suitable for 12kV continuous, 60kV or 75kV impulse level depending on the system exposure. Vacuum or SF₆ circuit breakers of suitable current rating and minimum fault level of 250MVA shall be fitted and be of the vertically isolated withdrawable type, spring operated, 110V DC motor wound, with shunt trip and closing coils and manual reset. Earthing provision shall be built in.

11.31 Each HV switchboard shall have one 110V battery for tripping duty and one 110V battery for closing and spring winding. Nickel/cadmium batteries shall be provided and they shall float across chargers capable of both rapid and trickle charging.

11.32 The Design Organisation shall be aware that a need may exist to coordinate the protection of HV circuits and certain LV circuits, such as transformer secondary outputs. HV relays shall be of the static type.

11.33 Sufficient controls and indicators shall be provided to allow safe operation by manual means.

11.34 Status and alarm monitoring of the switchgear shall be carried out both locally, by means of indication lamps on the switchgear, and remotely. Sufficient contacts shall be made available to enable the status to be monitored via the plant control system at remote locations. See Chapter 10.

11.35 The monitoring system shall be arranged to give a visual alarm of loss of a power supply.

Transformers

11.36 Each of the A and B power supplies shall be equipped with a transformer. The transformer shall be a 11000/400V Dy11 type, with sufficient kVA rating to enable one transformer to carry the whole of the required tunnel load without excessive temperature rise, although load shedding may be implemented to disconnect non-essential loads. Restricted Earth Fault protection shall be provided for the transformers.

11.37 Vector groups other than Dy11 may be more appropriate where large inductive loads are connected to the transformer.

11.38 Depending on earthing configuration and resistance, the neutral point of each transformer shall be earthed through an adequate link within the LV switchboard.

Low Voltage (LV) System

11.39 The design of the low voltage system shall be based on the following.

LV Distribution for Lighting, Electrical Distribution Panels

11.40 The LV switchboards shall provide separate circuits for the various stages of lighting, (emergency lighting shall also be connected to the UPS equipment).

11.41 Electrical distribution panels (EDPs) are required throughout a tunnel. It may be convenient to incorporate the electrical distribution points into the same cabinets as those provided for emergency fire and telephone services where these occur at the required intervals, see Chapter 8. The combined panels are referred to as emergency distribution panels EDPs. They shall be constructed of stainless steel and to IEC category IP65.

11.42 Within the EDPs two panel sections shall be provided, one for the A supply and the second for the B supply, see Figures 11.1 to 11.3. The distribution panels shall incorporate final circuit fuses and/or miniature circuit breakers feeding the tunnel lighting. Each distribution panel shall have sufficient distribution boards to feed the various lighting stages and a standardised unitised layout.

11.43 Lighting circuits shall be so arranged that, as far as practical, adjacent luminaires are connected to different circuits or, where two incoming supplies are available, to separate sources. By interleaving lighting circuits, failure of one will then only result in the loss of

50% of the lighting in the affected area and reduce the need to fall back on emergency lighting. Each lighting distribution sub-section shall be fed by a cable dedicated to the particular stage of lighting and each sub-section shall, therefore, be a separate unit within the A and B distribution panel capable of being isolated and worked on without danger from other sub-sections in the same distribution panel.

11.44 Special attention shall be given to the segregation of supplies derived from the UPS systems.

11.45 Equipment within the EDPs shall be rated for the temperature rise within the enclosures.

11.46 Particular care shall be taken in the design of the EDPs to ensure that adequate space is available for all equipment and connections. EDPs shall incorporate other electrical equipment such as connections for CCTV, communications, traffic loop detectors, control outstations etc. Suitable socket outlets (110V AC) for the TOA and special socket outlets for the use of the Fire Brigade may be required.

11.47 Care shall be taken to provide adequate terminations and space to allow reasonable bending radii of tails and outgoing cables.

11.48 Conduits for the final circuits from the EDPs to luminaires shall comply with IP65 and the use of stainless steel conduits and accessories is required. Final circuits shall be arranged to suit the characteristics of the lamps served (including starting currents).

11.49 BS7671 requires that the earthing bonding system from the services buildings shall be extended to each EDP to ensure the integrity of the earthing system by the provision of a separate circuit protective conductor (cpc) other than using the armouring of the sub-main cables. The cpc shall also be bonded to extraneous conductive parts.

LV Distribution for Ventilation

11.50 The electrical distribution, switchgear and control facilities shall be developed to suit each tunnel. The design shall recognise the need to ensure security of supply and the complete segregation of the electrical circuits for the ventilation from other systems.

11.51 Where fans are used to provide longitudinal ventilation along the length of a tunnel it is possible for the associated starter equipment to be located either in the LV switchrooms, or in panels local to the fans. It is usual to adopt the latter, except in short tunnels, with local control/starter panels, manufactured to a similar

specification as the EDPs, being provided for a group of fans. Cables between the LV switchrooms and the fan control panels shall be run to provide segregation between the fan supply cables and other systems, also between A and B supplies for the fans.

LV Distribution in Services Buildings, etc.

11.52 In addition to the LV supplies for lighting and ventilation, LV distribution is needed for the various services set out in Chapter 12. A “clean” supply may be needed for computer systems.

11.53 Earthing systems to provide equipotential bonding, frame earthing, neutral point earthing, computer system “clean” earths and general protection shall be considered when designing Services Buildings. High quality copper systems shall be installed and allowance made for the testing facilities to be provided. The laying of earth electrode mats may be required before building superstructure work commences. The bonding system may require to be extended to connect equipment outside the Services Building.

LV Switchboards

11.54 LV switchboards shall be suitable for operating on a 400V, three phase, 4 wire, 50 Hz supply with ingress protection to IEC IP31. They shall be fault rated for 50KA for 1 second.

11.55 Switchboard enclosures shall be of cubicle construction, with units mounted in tiers within each cubicle, assembled to form a flush fronted, floor mounted, free standing, dust protected metal enclosure having 1 to 1.25m minimum access from the front, with bottom cable entries whenever possible. To allow for future requirements, a minimum of 25% spare ways shall be included. The maximum overall height of the switchboards shall be 2.2 m to aid access and operation, with the operating switches and dial reading instruments at a maximum height of 2.0m, minimum height 0.45m, from the finished floor level. Switchboards shall be arranged with 2.5m free space at the front and back and 2m at each end.

11.56 Each switchboard shall include all necessary air circuit breaker units with 110 volt (close) and 110 volt (trip) DC motor wound spring operated mechanisms, with provision for hand and remote closing and opening. The 110V DC supplies shall be derived from twin battery systems similar to those described under HV System.

11.57 The switchboard is normally divided into two busbar sections (A and B) and interconnected through a busbar circuit breaker. Sections A and B would be fed from each of the transformers, respectively. If required, a third Section C would be fed from the standby generator.

11.58 The neutral of each transformer shall be brought into the LV Switchboard and fitted with a suitably rated neutral link to facilitate neutral isolation and earth continuity tests.

Protection Systems

11.59 All protection systems for the LV distribution shall be compatible. Certain HV protection circuits or circuit breaker operations may require a response from the related LV protection system.

11.60 When specifying any form of protection system, it is necessary to ensure that discrimination is maintained throughout each circuit and sub-circuit, to prevent tripping of higher level circuits.

Interleaving of LV Supplied Equipment

11.61 To minimise the risk of a complete failure of services in any section of tunnel, in the event of a failure of one of the primary supplies, equipment such as luminaires and jet fans shall be alternately connected to power supplies derived from the A and B sources as shown in Figures 11.1, 11.2 and 11.3. Cables from the two supplies shall be routed separately to minimise the risk of loss of both circuits simultaneously.

Uninterruptible Power Supply (UPS)

11.62 An uninterruptible power supply, with appropriate autonomy, is essential, in the event of a main electrical supply failure to maintain power to operational and safety systems and permit use of the tunnel to continue. Failure of the normal supplies causing sudden loss of tunnel lighting could lead to the disorientation of a driver entering or already in a tunnel. It is essential that some level of lighting is maintained throughout the whole of the initial period of supply failure.

11.63 Other systems essential to safety, such as emergency lighting, fire protection, communications, alarm and traffic control systems, shall be provided with emergency battery backup power to ensure that the tunnel can be safely evacuated, and incidents identified and attended to, should an alternative power supply also fail. Vital equipment such as data

logging, CCTV, traffic control signs, emergency service communication systems, computers (particularly SCADA and control systems), equipment which cannot tolerate any interruption during switching operations or while any standby generator is starting up, and essential support services situated in the services buildings shall have a guaranteed secure electrical supply.

Emergency Lighting

11.64 Since failure of the normal power supply will result in total loss of tunnel lighting unless standby arrangements are made, careful consideration shall be given at the planning stage to the probability of supply failure and the operational requirements in such an event. Provision of a permanently available, independent second mains supply will reduce this risk, but can be a costly option and cannot guarantee complete freedom from supply outages.

11.65 As a minimum requirement, one luminaire in ten of the Stage 1 lighting shall be designated as emergency lighting and maintained by a UPS. This will provide sufficient light for safe evacuation of the tunnel, but not for continued operation with traffic, and the tunnel shall then be closed until full power is regained. Daylight penetration and vehicle headlights may be of assistance, but cannot be relied upon.

11.66 Where tunnel closure is unacceptable, sufficient standby lighting shall also be provided to permit the safe passage of traffic, with an appropriate signed speed restriction. This may be achieved by maintaining the normal daytime interior zone lighting (Stages 1 and 2) but switching off the boost lighting in the entrance and exit zones (Stages 3 and above). The standby lighting load is usually too large to be supported by a UPS system alone, and a standby generator shall be provided to power this and other essential loads. UPS capacity then only needs to be sufficient to maintain continuity of lighting between the moment of supply failure and acceptance of the load by the standby generator.

Essential Service Loads for UPS

11.67 The essential loads shall be listed and quantified, and sufficient UPS power shall be provided to allow such services to be maintained until either any main standby generating equipment is brought into operation, or a predetermined tunnel evacuation and diversion of traffic is achieved if no standby generator provision or in the event of a failure of standby generation to start.

11.68 The essential loads shall be permanently connected to the UPS equipment so that in the event of a mains failure their supply is maintained.

11.69 Components of the essential load shall include

- i. Approximately 10% of the Stage 1 lighting, as described
- ii. Computer control and fault indication systems
- iii. Sub-surface communications systems including CCTV
- iv. Radio Systems
- v. Tunnel portal signals/signs
- vi. Fire Brigade power tool sockets (if required by Fire Brigade)
- vii. Other relevant components unique to the tunnel under consideration.

Type of UPS

11.70 Static type systems with a no-break reversion to the mains supply on failure are adequate for tunnel applications using appropriate battery capacity. Rotary types may be considered.

UPS Design Parameters

11.71 Each UPS system design shall take account of the following factors:

- i. The type of load to be fed and the characteristics (eg p.f and current inrush) of the load
- ii. Acceptable limits of harmonics fed back into the power supply network, particularly where a standby generator is installed
- iii. Compatibility with standby generator plant, where provided
- iv. The minimum period of time the UPS is required to operate under full load after mains supply failure (normally two hours)
- v. Operational and physical compatibility with other electrical equipment
- vi. Recharging times after discharge. Batteries shall be capable of being fully recharged, from the 75% discharge state, in seven hours, automatically

- vii. Control equipment to be provided.

Standby Generating Equipment

11.72 Where it is likely that drainage pumps or ventilation plant will need to be operated under mains failure conditions to maintain the security of the tunnel systems and structure, such loads will be beyond the capacity of a UPS. For such cases, automatic start standby generating equipment shall be considered.

11.73 Separate accommodation, with 4 hours fire protected enclosure, shall be provided for the standby generating equipment, fuel tanks etc.

11.74 As an alternative to permanently installed standby generating plant, consideration may be given to the provision of suitable connecting points for the use of mobile generators. The availability of a suitable generator shall be carefully assessed, particularly taking into account competing demands that may be made for use of such plant and the likely time required to bring the mobile generator to the tunnel site.

Essential Service Loads For Standby Generating Equipment

11.75 shall be rated to provide adequate power, including starting currents, for the essential loads listed for the UPS plus the requisite pumping system loads, including fire main pressure pumps, if installed. If surplus power is available, additional loads may be connected in the following order of priority:

- i. Essential ventilation plant
- ii. Lighting and HVAC equipment in Services Buildings
- iii. Limited tunnel lighting (normally Stages 1 and 2) according to the design requirements.

Standby Generator Design Considerations

11.76 A standby generator, where required, may be specified to accept load in two stages, the first not exceeding 60%, and the system design shall allow for this.

11.77 Output shall be connected to the LV switchboard Section C, see Figure 11.3. In the event of a power supply failure of the primary supplies, the system shall automatically bring the standby generators into operation and isolate Sections A and B of the LV switchboard.

11.78 Fuel storage tanks, shall store sufficient fuel for seven days running at full load. A dump tank shall be provided external to the diesel set room to take the contents of the day service fuel tank which will empty automatically should a fire occur in the diesel room. The dump tank shall be provided with pumps to empty it.

11.79 Separate accommodation shall be provided for the standby generating equipment, fuel tanks etc.

11.80 Provision shall be made to generate from, and transmit to, the tunnel site all necessary signals and controls to and from the standby generator sets.

Cabling

11.81 Cable fire protection shall be in accordance with the requirements of Chapter 8. Design of cabling shall also be based on the following.

Services in the Tunnel

11.82 Cables feeding services in the tunnel shall be run, so far as is possible, in the verge ducts on either side of the bore. Preference shall be given to lighting sub-mains being run in the verge duct adjacent to the left hand carriageway side. Where ventilation using jet fans is employed, cables feeding these fans shall be located in the verge opposite to that containing the lighting cables.

11.83 Fixings for cables, if they are cleated, shall be provided at intervals not greater than those stated in BS 7671.

Services Below Ground (Outside the Tunnel)

11.84 Where cables are to be buried in the ground, the depths of cable trenches shall be defined so that there is no ambiguity regarding the depth required. For example, it may be specified that an LV cable shall be laid at a minimum depth of 450mm on a bed of sand 150mm deep (ie. a trench depth of 600mm). Cable tiles or marker tape shall be provided over the installed cables.

11.85 Where cables are housed in glazed or plastic duct pipes, it shall be arranged, where economically practical, for only one cable to be installed in each pipe. At least 25% spare ducts shall be provided, above the initial assessment, to allow for future requirements.

Services in Switchrooms and Services Buildings

11.86 The design of switchrooms and service buildings shall allow for adequate space for known and possible future cable routes beneath floors. See Chapter 12. In

switchrooms, floors shall be of the suspended type with approximately 1m of space below them, and shall conform with the Building Regulations and Local Authority requirements. Fire partitioning and barriers to aid system segregation shall be incorporated.

11.87 In switchrooms or similar locations, cable trays shall be designed and erected so that they do not sag when the cable installation is completed. All fixings and accessories shall be of stainless steel, or, when not exposed to the tunnel environment, hot dipped galvanised materials may be used. Wall or ceiling mounted support systems to the cabling may be required. Such systems need to be purpose designed for each project.

11.88 Entries to equipment shall be arranged to give access to cables approaching from below. In the case of major short interconnections (eg. between the LV terminals of a transformer and a main LV switchboard) consideration may be given to the use of bus duct connections rather than cable, but care needs to be taken in the physical layout of the equipment to ensure maximum economy.

11.89 Cables shall not be run beneath the floor in battery rooms.

Cable Design Requirements

11.90 Cables shall have copper cores. Cable cores shall be stranded (except for MICC cables) where used on any part of the lighting, power distribution, final circuit and control systems. Care is required in the selection of cable entry glanding materials suitable for a road tunnel environment, see Chapter 2.

11.91 All HV cables shall be manufactured to suitable standards and shall be XLPE insulated, steel wire armoured and red LSOH sheathed.

11.92 All LV cables for general purpose use outside the tunnel shall be to the Manual of Contract Documents for Highway Works.

11.93 Low Smoke Zero Halogen (LSOH) insulation and sheathing materials, with an emission of HCl of not greater than 0.5%, shall be used for all cables partially or completely inside the tunnel and its substations. They shall conform to one of the following specifications:

- i. LSOH/SWA/LSOH (Cu) construction,. Armouring shall be round galvanised steel wire with a black LSOH oversheath, suitable for permanent immersion in water. The cable to be rated at 600/1000V.

- ii. LSOH/LSOH (Cu) LSOH insulated, LSOH sheathed overall, stranded copper conductor power cables suitable for use on an earthed system at rated voltage of 600/1000V.
- iii. LSOH insulated copper conductor wiring cables rated at 450/750V installed in heavy gauge conduit.
- iv. MICC/LSOH Mineral insulated copper conductors, with a LSOH outer sheathed overall rated at voltage of 600/1000V, generally used for fire alarms (with a red sheath) and other applications where resistance to high temperatures is required.

LV Cable Sizing

11.94 Long route lengths may require the use of cables having large core sections to meet the voltage drop, disconnection time requirements and the power correction factors for groups of cables. Cable terminations shall be sized to suit these requirements.

11.95 As the distance between the low voltage switchboard and the furthest fan or luminaire increases, cable sizes may need to be increased to compensate for the drop in voltage along the cables. Voltage drop in the LV cable system may be reduced by the provision of more frequent sources of supply, through the extension of the HV system to additional substations. In tunnels longer than 400m, more than one transformer substation will probably be needed to avoid undesirably long low voltage circuits.

11.96 A cost benefit analysis shall be undertaken to assess the benefits of providing such additional substations compared to the provision of larger cross section LV power cables.

Other Cables

11.97 Other types of cables to the relevant specifications may be used for other tunnel purposes and include:

- i. General purpose cables outside of the tunnel
- ii. Heating appliance cables
- iii. Industrial heavy duty cables
- iv. Multipair communication cables
- v. Radiating co-axial cables

- vi. Optical fibre cables
- vii. Intruder alarm and fire alarm cables.

Cable and Termination Identification

11.98 A system of identification for cables, and cable cores in terminations, shall be established and recorded.

11.99 Except where buried in the ground or in enclosed ducts, all cables shall be identified externally by standard cable markers, fixed over the external sheath, at intervals not exceeding 25 metres. All cables shall have the same identification provided at each cable termination, at each change of direction and where passing through barriers.

11.100 Cable cores and terminations shall be identified, with a previously agreed code of alphabetic and numerical symbols, by means of pre-engraved indented circular markers closely fitted to the core insulation of each constituent core. Cores not utilised shall be identified as 'spare' and shall be terminated in a spare terminal arrangement of the same pattern as that used for the 'in use' cores.

11.101 Cable voltage ranges shall be indicated by the colour of the outer sheath, eg red sheath for HV, black sheath for LV and the sheath for control cables to be of some other distinguishing colour.

Cable Segregation

11.102 Throughout an installation, strict segregation shall be maintained between services derived from different sources, or operating at different voltages, or whose operating characteristics may interfere with the satisfactory operation of other cables or services.

- 1,2 = Incoming HV Supplies
- A,B,C,D = LV Supply Sections
- N/O = Normally Open Circuit Breaker
- X = Circuit Breaker
-  = LV Switchgear

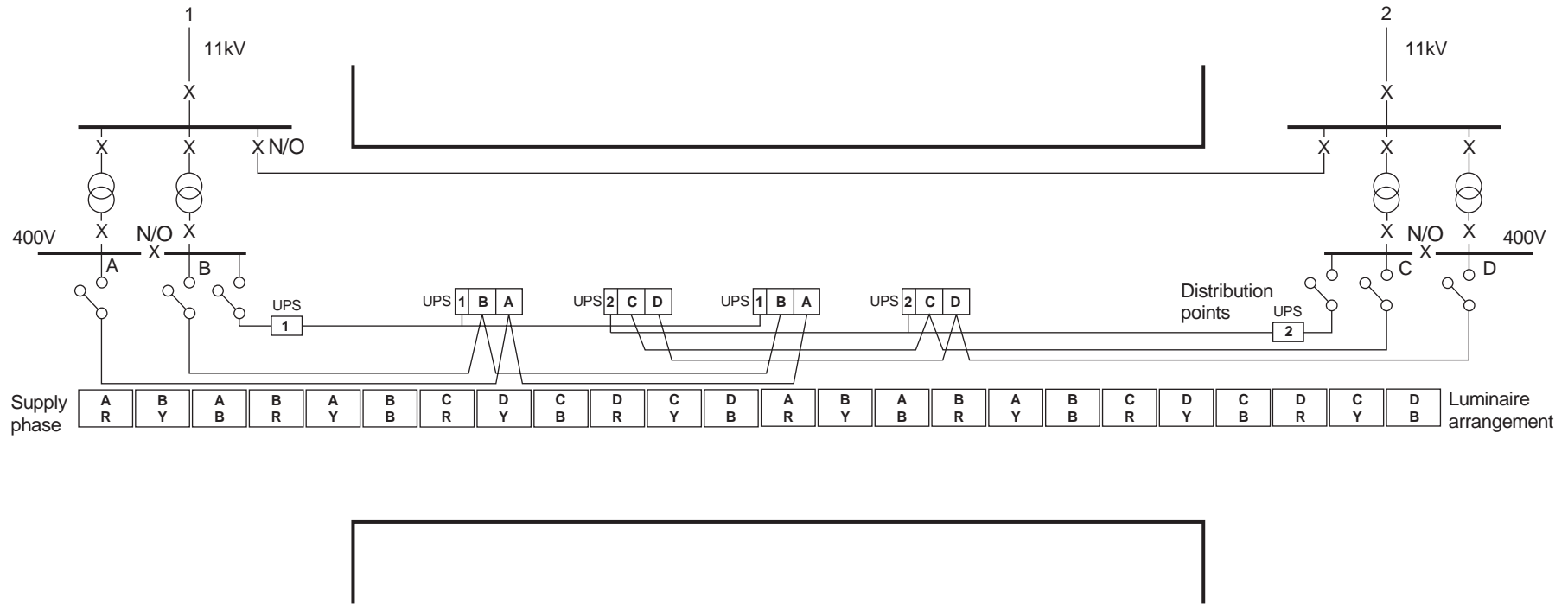

(Note:Electrical loads are shared as equally as possible between LV supply sections A,B,C,D)

**Typical Tunnel Power Supply System
HV Supply at Each End of Tunnel**

Figure 11.1

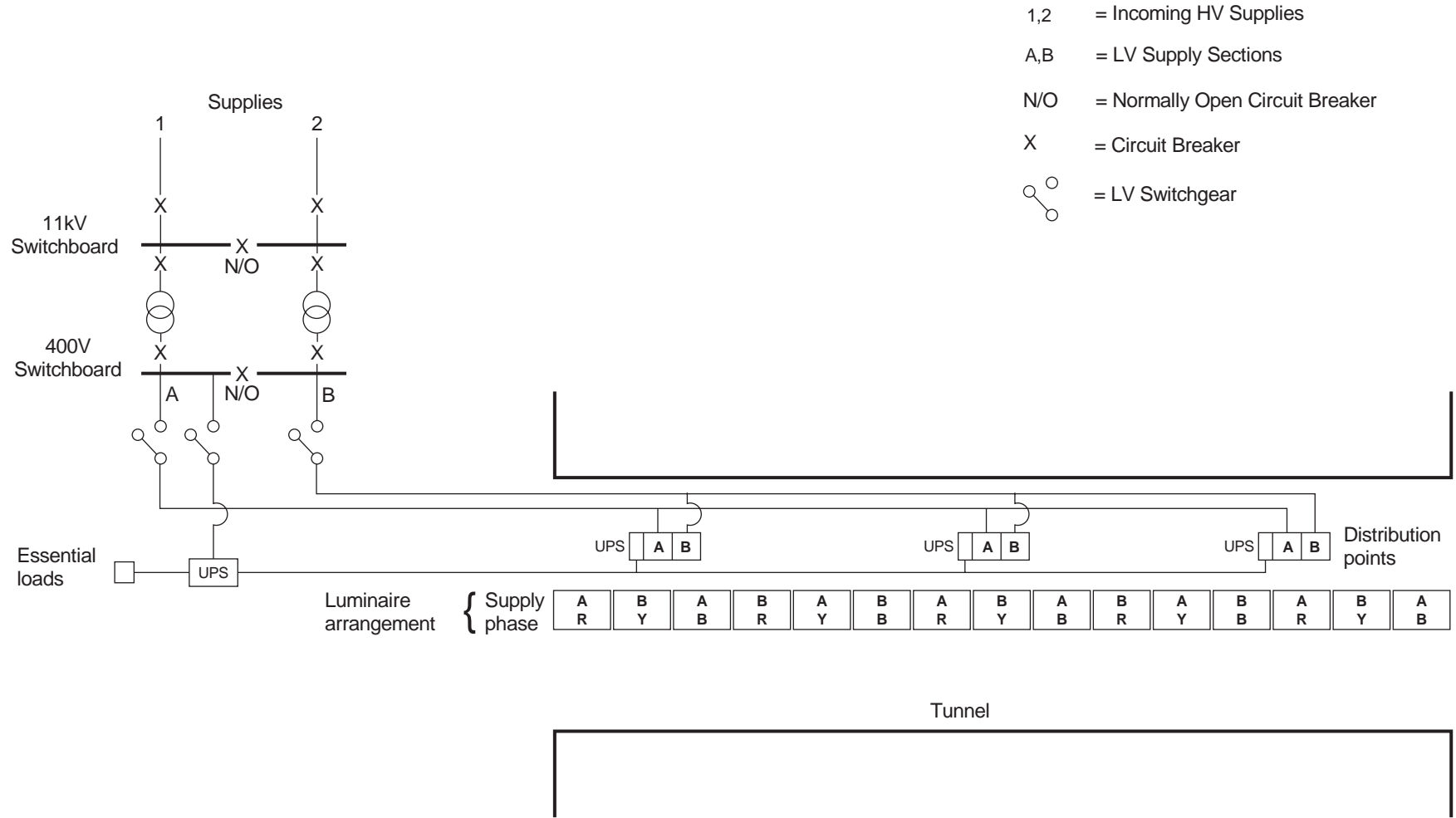

- 1,2 = Incoming HV Supplies
- A,B = LV Supply Sections
- N/O = Normally Open Circuit Breaker
- X = Circuit Breaker
-  = LV Switchgear

(Note:Electrical loads are shared as equally as possible between LV supply sections A,B)

**Typical Tunnel Power Supply System
HV Supply at One End of Tunnel**

Figure 11.2

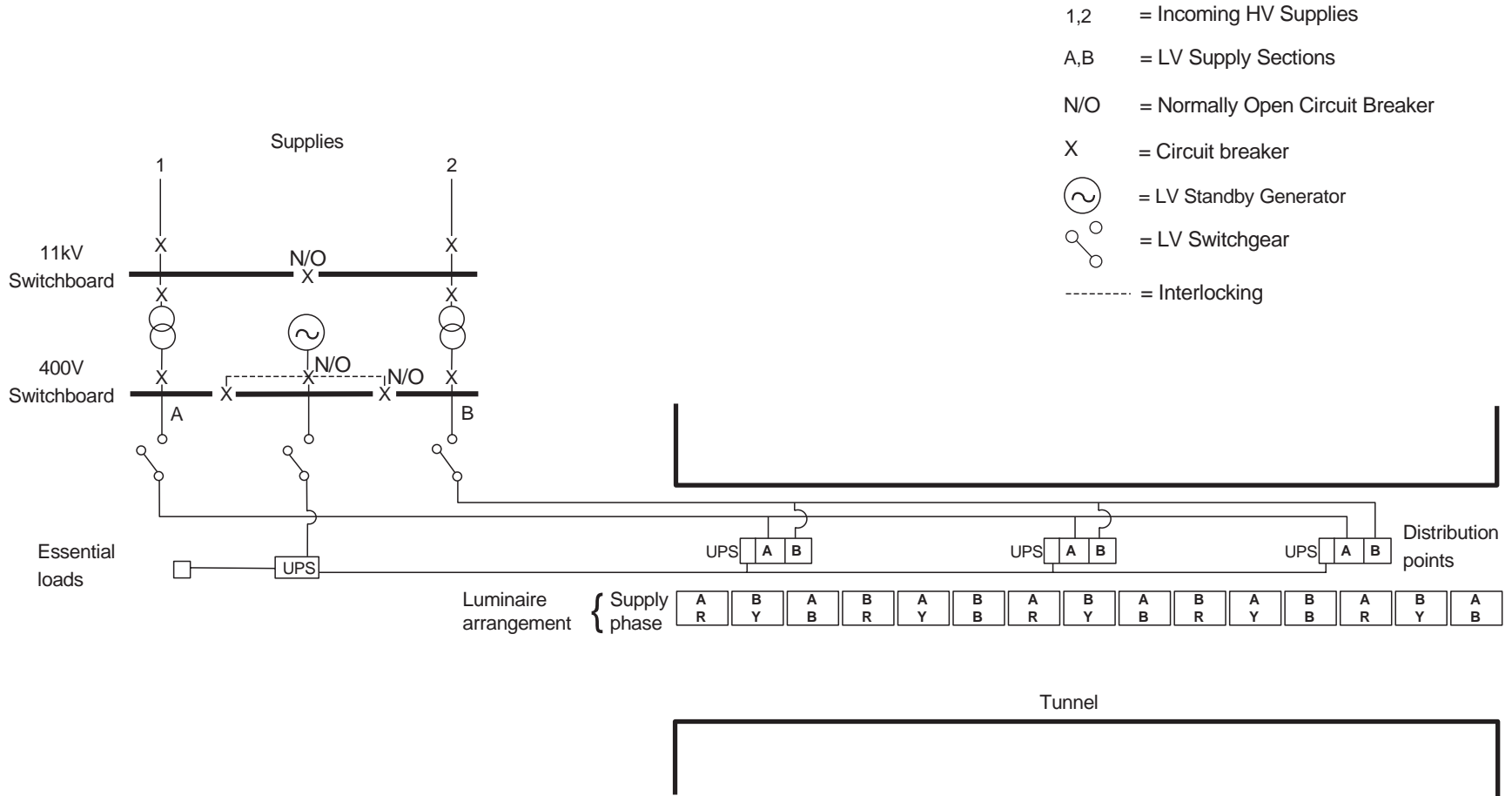

(Note:Electrical loads are shared as equally as possible between LV supply sections A,B)

**Typical Tunnel Power Supply System
with Standby Generator**

Figure 11.3

12. SERVICES BUILDINGS AND PLANT ROOMS

General

12.1 Tunnel Services Buildings and Plant Rooms house the main electricity substation, plant rooms and temporary control centre for a tunnel. Additional structures may be required for substations and plant rooms at other locations adjacent to the tunnel. Plant rooms shall be sized not only to accommodate the plant and associated systems to be installed initially at the tunnel, but also to provide for any foreseeable future requirements.

12.2 Building layout shall facilitate effective management of operations and maintenance and fully reflect the system of tunnel management to be adopted eg manned or unmanned tunnels. If the Services Buildings are normally unmanned, they shall be suitable for occasional use as a temporary control facility during maintenance and emergency operations.

12.3 The siting and requirements of the Service Buildings are discussed in Chapter 2.

12.4 Tunnel complexes including Services Buildings shall comply with the requirements of the Building Regulations and water bye-laws etc.

12.5 In addition to the facilities required for the tunnel equipment and systems, maintenance workshops, stores, messing and toilet facilities may be required for operational, maintenance and contractors' staff. Outside the main building a vehicle hard standing is required with access for fire fighting vehicles, equipment and personnel. A helicopter landing pad may need to be considered at major tunnels.

12.6 Access to the Services Buildings shall be strictly controlled and access facilities managed to prevent unauthorised entry and operation of plant. Adequate security arrangements shall be provided to protect all materials and equipment.

12.7 As well as normal lighting, the provision of emergency lighting (for escape under mains failure conditions) and standby lighting (to permit continued use of selected areas if normal power fails) shall be provided.

Design and Layout

Space and Provision Requirements

12.8 A layout of an example services building for a road tunnel is shown at Figure 12.1.

12.9 Space and suitable cable access may be required for each of the following:

- i. Electricity Supply Authority intake and metering
- ii. 11 kV switchgear
- iii. Transformer pens
- iv. Diesel generator, fuel tanks and dump tank
- v. UPS and battery equipment
- vi. LV switchgear including control and interface panels for lighting and ventilation systems
- vii. Fire protection systems
- viii. HVAC plant
- ix. Drainage pumping equipment and associated electrical equipment
- x. Computer, control systems and peripherals
- xi. Radio and telephone communications equipment (possibly also a secure area for police network)
- xii. Protected mains sockets for portable tools and test equipment.

12.10 Adequate space shall be provided for opening of cabinet doors and access to switchgear. Allowance shall be made for cable runs and bend radii.

Cable and Equipment Separation

12.11 To minimise the risk of radiated interference communications equipment and cables shall be located as far as possible from high voltage and low voltage switchgear and cabling and generator plant.

Heating and Ventilation

12.12 Heating will be required in all rooms, to prevent condensation. Rooms containing LV switchgear, UPS plant and batteries and electronic equipment may require air conditioning to maintain an acceptable operating temperature for the equipment. Most types of commonly used batteries can evolve hydrogen gas under certain conditions and ventilation shall be provided to prevent any dangerous build-up of gas.

Floors

12.13 Floor loadings of all electrical equipment shall be calculated and taken into account for in the civil engineering design. The requirement for providing false floors for cabling is described in Chapter 11.

12.14 Cables shall not be run beneath the floor in battery rooms. The floors in the battery rooms shall be of solid construction and finished with a dust and alkali resistant surface. The floor shall have drainage outlets to allow for electrolyte and cleaning water removal. These outlets may be connected to the sink drain within the room.

Earthing and Cabling

12.15 See Chapter 11 for cabling and earthing requirements in Services Buildings and Switchrooms.

Lightning Protection

12.16 An assessment of the need for lightning protection for the Services Buildings shall be carried out as described in BS 6651:1992 and a suitable lightning protection system installed if necessary, in accordance with the same Standard.

Building Security and Fire Protection

Intruder Alarm System

12.17 The Service Buildings shall be provided with an intruder alarm system comprising magnetic door switches and break glass window contacts on all external doors and windows. Where necessary internal areas (eg the roof space) may be additionally protected by passive infra-red (PIR) or microwave movement detectors. In the case of roof voids, consideration shall be given to the risk of false alarms which may be caused if birds etc can gain access.

12.18 Operation of a mortice type door key switch at the Services Buildings shall initiate a "Staff on Duty" signal for logging by the SCADA system. Forced entry through any of the outside doors or windows will break an electrical contact and trigger an alarm condition which will then activate an external alarm bell and transmit an alarm signal to the operator and/ or the Police via the SCADA system. See Chapter 10.

12.19 An external self-contained alarm bell shall be provided with its own battery unit and internal relays so that in the event of the wires being severed or the bell removed, it shall be instantly activated.

Fire Alarm and Extinguishing Systems

12.20 A fire alarm and automatic fire extinguishing system shall always be provided in the Service Buildings. See Chapter 8.

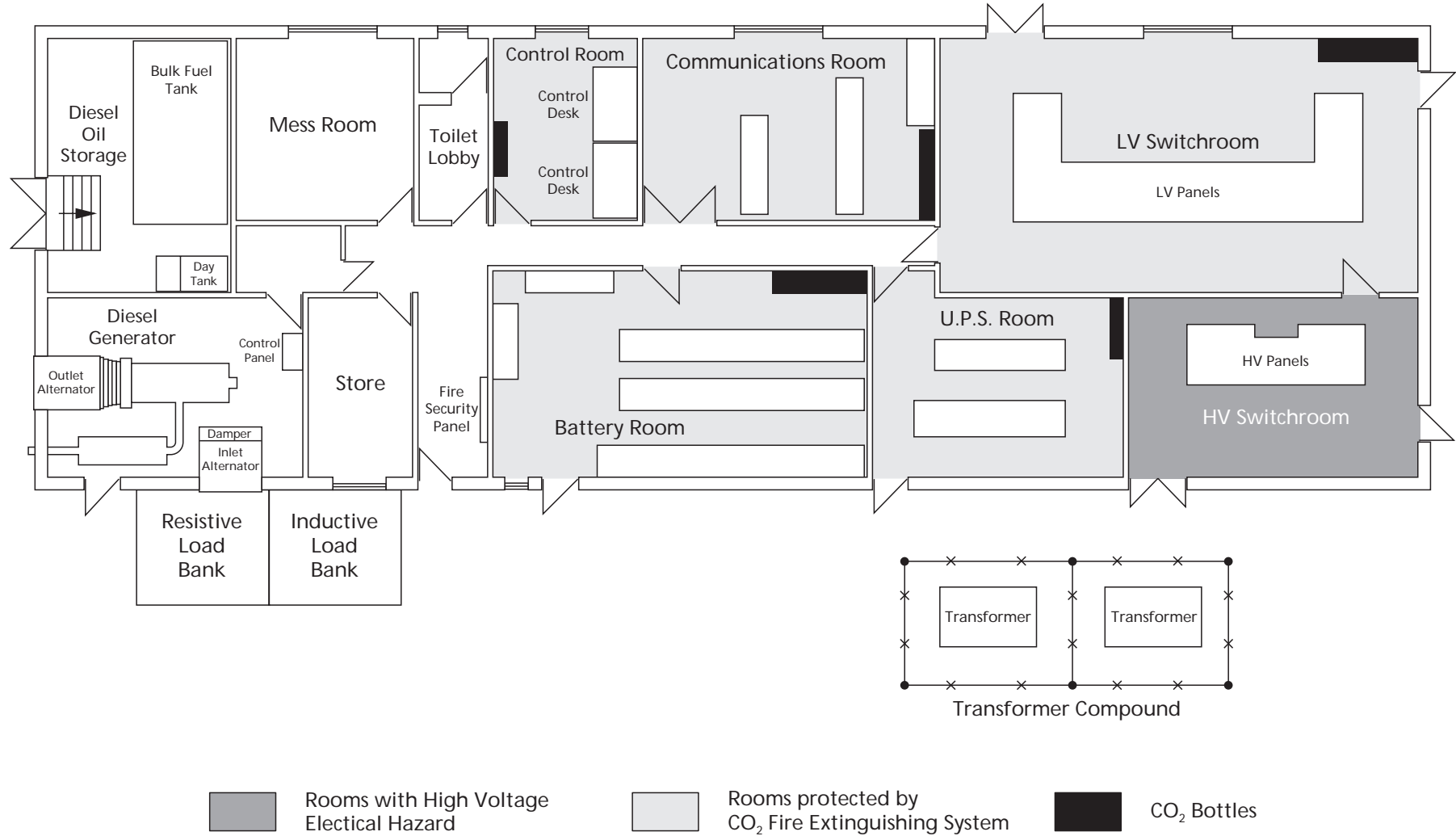

Note: LV Switch Room, Communications Room & Control Room typically have suspended floors

Figure 12.1

Indicative Tunnel Services Building

13. TUNNEL COMMISSIONING, HANDOVER AND OPERATIONAL DOCUMENTATION

General

13.1 Adequate tunnel documentation is essential to provide a record of the 'as built' installation, equipment test results including those for statutory purposes, operating and maintenance procedures and emergency drill for all the authorities who respond to incidents. The ease of understanding and ready availability of essential information from the relevant documents is essential to maintain traffic flow, ensure efficient working of staff and equipment, and continued provision of safe conditions.

13.2 Detailed technical specification requirements for road tunnel equipment may be found in the Manual of Contract Documents for Highway Works: Volume 5: Section 7: Mechanical and Electrical Installations in Road Tunnels, Movable Bridges and Bridge Access Gantries.

13.3 To ensure that the documents are correctly compiled and well presented, they shall be written by competent technical authors to form a single, coherent cross-referenced package.

13.4 The documentation supplied shall be designed to meet the needs of the tunnel operator for specific day-to-day safe operating needs, as well as the needs of periodic inspection and planned and emergency maintenance. The information shall be prepared in the form of indexed hard copy manuals, but consideration should be given to specifying that manuals and drawings shall also be prepared to an agreed electronic format which would offer significant benefits in ease of retrieval, transmission and updating of information as well as reduced storage space. The storage of indexed information on CD-ROM, or latest equivalent, with hypertext links may be particularly convenient.

13.5 Of special importance is the documentation prepared to assist the police and emergency services responding to tunnel incidents and emergencies. This shall present clear and concise information and accurately reflect the agreements reached between the parties of the TDSCG.

13.6 All drawings, test certificates and calculations shall be produced by the Contractor and signed as approved by the Design Organisation.

SUMMARY OF RECORDS REQUIRED

13.7 A summary of the documentation required for a new or refurbished road tunnel is as follows. A description of the various documentation is given later in this Chapter. Typical contents are listed in Appendix C.

13.8 The Contractor is required to provide the following documentation with timeliness, clarity and comprehensiveness:

- i. Tunnel Commissioning Records
- ii. Certificate of Practical Completion, Handover
- iii. As Built Records
- iv. Operator's Guide
- v. Operation and Maintenance Manual
- vi. Inspection Check List
- vii. Computerised Data Recording Forms.

13.9 The Design Organisation is required to provide the following documentation with timeliness, clarity and comprehensiveness:

- i. Report of the TDSCG (see Chapter One)
- ii. Manual for Police and Fire Services.

13.10 The police, fire and ambulance services are required to provide the following documentation, as appropriate, with timeliness, clarity and comprehensiveness:

- i. Emergency Services' Operational Manuals
- ii. Police Control Centre Operator's Manual.

TUNNEL COMMISSIONING RECORDS

13.11 The commissioning phase of a road tunnel project is to ensure that the complete installation of M&E plant and equipment functions properly and is certified fit for its intended purpose, before handover to the tunnel operator.

13.12 The outline design of M&E functions of a road tunnel will be undertaken by the Design Organisation. Much of the detailed design and selection of plant and materials rests with the Contractor through his appointed manufacturers and specialist subcontractors. Documents relating to design information and the commissioning process will need to be provided for record, handover and warranty purposes and shall include:

- i. Records comprising relevant letters relating to specific equipment, agreements and minutes of meetings.
- ii. Alert Notices and Field Service Reports comprising the list of any faults which arose during inspection, and the remedial actions, adjustments and modifications carried out.
- iii. Works Test Certificates covering general matters such as electrical continuity, insulation and enclosure checks, and specific performance checks, such as fan or pump volumetric tests or photometric tests for lighting. See the Manual of Contract Documents for Highway Works: Volume 5: Section 7: Mechanical and Electrical Installations in Road Tunnels, Movable Bridges and Bridge Access Gantries.
- iv. Site Test Certificates verifying the performance of all equipment and systems after installation on site, with full test results, signed and countersigned.

CERTIFICATE OF PRACTICAL COMPLETION, HANDOVER

13.13 Towards the end of the construction period, when all the equipment has been tested and found to be in accordance with the specifications and in good working order, a Certificate of Practical Completion, or equivalent, shall be issued, certifying the date on which the tunnel was substantially complete. Issue of this certificate marks the date of handover to the Maintaining Agent (acting on behalf of the Overseeing Organisation), commencement of the 12 months defects liability period, and of full payment, apart from any retention, of all monies due for the works. For DBFO projects the same procedure shall be followed. It shall be noted that the 12 months period referred to shall not be confused with any manufacturer's warranty period starting from the date of supply for particular pieces of equipment.

13.14 Since at handover, the Maintaining Agent is required to accept responsibility under the relevant Health and Safety legislation for the safe operation of

the tunnel, it is imperative that no representative of the Overseeing Organisation should sign the Certificate of Practical Completion until complete operating and maintenance documentation is available. For DBFO projects the same principles shall apply. It is very beneficial if the Maintaining Agent, or equivalent, staff can witness the final commissioning and testing stages, for familiarisation purposes. The contract documents will contain the requirements for training that is to be provided, see Manual of Contract Documents for Highway Works: Volume 5: Section 7: Part 2: 7015: Mechanical and Electrical Installations in Road Tunnels, Movable Bridges and Bridge Access Gantries.

13.15 To enable the operating and maintenance documentation to be considered for approval by the Overseeing Organisation, in time for handover, final drafts of the manuals and drawings shall be submitted for approval to the Overseeing Organisation 6 weeks in advance of the target date for practical completion.

13.16 After practical completion and at handover, all of the documents listed in this Chapter shall be bound together in separate volumes, and retained by the tunnel Maintaining Agent (or DBFO Contractor) for future reference such as during inspections and maintenance of tunnel equipment. The Maintaining Agent (or DBFO Contractor) shall also be responsible for updating the documents (except for those from the emergency services), as necessary, to record changes in the installations or procedures.

Handover Certificate

13.17 When all performance tests have been completed satisfactorily, and in accordance with the Specification, a Certificate of Practical Completion will be issued, to certify the date on which the tunnel was contractually completed and handed over to the Overseeing Organisation.

AS BUILT RECORDS

13.18 A full record of the entire road tunnel installation, as built, shall be provided to the tunnel operator at the time of acceptance of responsibility for maintenance. This shall include site plans, and tunnel layouts showing access provisions and facilities for the emergency and maintenance services, together with plans and descriptions of buildings for tunnel services and associated ancillary structures such as sub stations, sumps etc. See BD53 (DMRB 3.1.6).

OPERATOR'S GUIDE

13.19 The Operator's Guide for the tunnel and its equipment should include all the drawings and specifications for the equipment provided, and the general procedures for its day to day operation and maintenance.

OPERATION AND MAINTENANCE MANUAL

13.20 The Operation and Maintenance Manual shall include all the detailed manufacturer's operating and maintenance instructions and recommendations for the equipment, spare parts lists etc. The information shall also be supplied on a computer readable source eg CD-ROM. Any spare parts recommended shall have a confirmed availability for the working life of the equipment or at least 10 years. The Tunnel Operator may either rely on storage and provision of spares by the original manufacturer or consider entering into an agreement with a spares provision agency.

INSPECTION CHECK LIST

13.21 To facilitate planned maintenance, inspection check lists shall be provided for the inspection and maintenance operations required to be carried out for each item of equipment, at specified intervals. The check list shall be designed to simplify the entry of record data into a tunnel maintenance database.

COMPUTERISED DATA RECORDING

13.22 Operation and Maintenance (O&M) database systems (see Appendix C for content details) shall be provided in order to enable improved organisation, improved operational reliability, logical sectioning of work and identification of cost sources for cost control. Software shall be compatible with systems, if any, of the Overseeing Organisation. Work sheets, in logical groupings, for scheduled maintenance shall be generated by software. Data entry forms shall be provided, listing all tunnel equipment, with the relevant computer data recording system entry code for group and individual entry. Compatible software and instructions shall be provided for accessing, by maintenance and inspection staff, comparative data and trends for the equipment provided. The forms should not need to be retained after electronic data has been entered and processed. SCADA (see Chapter 10) is to supply a proportion of the incident and record data required by BD53 (DMRB 3.1.6).

13.23 A computerised register shall be provided for recording inspectors' electronic signatures on completion of the scheduled inspections. Parameters shall be provided which ensure that adverse data records are reported.

13.24 An option shall be available to allow for the data base to be reset, if necessary, following major refurbishment work, this function should not be accessible to the inspection staff.

13.25 Data review would be undertaken only by authorised personnel, and an alarm should be arranged to inform the Tunnel Manager when reviews becomes due. A hard (printed) copy of the review should be retained and used to record long term trends of equipment performance.

REPORT OF THE TDSCG

13.26 The decisions effecting the design and operation confirmed and agreed at TDSCG meetings must be formally recorded into a finalised Report of the TDSCG, and accepted as an agreed addenda to the Approval In Principle (AIP) document required by BD2 (DMRB 1.1). See Chapter 1.

MANUAL FOR POLICE AND FIRE SERVICES

13.27 A manual shall be produced for the guidance of staff at the local police and fire stations and control rooms. The manual should briefly describe the principal features of the tunnel, including operational procedures and detail the facilities available to assist the police and fire services in dealing effectively with incidents and emergencies in the tunnel. It should be clear and simple.

EMERGENCY SERVICES' OPERATIONAL MANUALS

13.28 Police and fire services' operational manuals for the particular road tunnel are to be prepared separately by the relevant organisations concerned, fully taking into account the agreements of the TDSCG, and including the requirements of the ambulance service. Procedures generic to the force or service need not be repeated in such documents. The text should identify who does what, where and when, communication channels and equipment needs for the particular circumstances of the road tunnel in question. Typical contents of police and fire services operational manuals are given at Appendix C. Guidelines for emergency (major incidents) operations are given at Appendix D. Together with the

relevant information included from Chapter 14: Tunnel Operation, such guidance will form the basis for the detailed Emergency Services and Police Control Centre Operational Manuals for the operational circumstances relevant to a particular tunnel. Such manuals shall be regularly updated, at least every 3 years, and incorporate any changes to procedures and the findings from any emergency drills to BD53 (DMRB 3.1.6).

POLICE CONTROL CENTRE OPERATOR'S MANUAL

13.29 A separate manual relating to tunnel emergency operation to assist the Duty Officer at the Police Control Centre shall be prepared by the police.

14. TUNNEL OPERATION AND MAINTENANCE

General

14.1 Road tunnels involve high capital investment and every effort needs to be made to optimise their productivity in terms of continuous availability for traffic throughput. This must be kept in mind when devising maintenance procedures and measures to ensure appropriate levels of operational safety. The tunnel must be designed and operated as an integral part of the highway and not as a potential bottleneck within the network. A road tunnel is usually an important link in the highway system and is often located where there are few, if any, viable alternative traffic routes.

14.2 The overall framework set up to operate each tunnel on a day-to-day basis, execute planned maintenance, control tunnel traffic and respond to tunnel emergencies will depend on local circumstances and will deal with a wide range of issues affecting safety and economy. The proposed framework will have influenced the initial risk assessment.

14.3 The Tunnel Operating Authority (TOA) is the competent body, providing a nucleus of trained staff who are fully familiar with the operation, inspection and maintenance requirements of the tunnel functions, together with the necessary maintenance plant and equipment, which is responsible for the tunnel operation and whose staff are also capable of providing advice and assistance to the police and emergency services.

14.4 As described in Chapter 2 certain tunnels require on site permanent staff dedicated to their operation. More generally, tunnels will be designed to operate automatically, with remote supervision, and are unattended. However, there must still be a rapid response in the event of equipment failure or other emergencies.

14.5 Such staff shall provide emergency cover on a 24 hour basis, with a schedule of agreed response times, to attend to equipment faults and emergencies and shall be required to oversee any maintenance work that is contracted out (eg cleaning walls, bulk re-lamping etc). They shall also, where necessary, include qualified and authorised personnel to comply with statutory safety procedures such as permit-to-work systems relating to high voltage equipment and confined spaces.

14.6 The relative emphasis that needs to be given to the above considerations shall be clearly defined in the operational manuals to be prepared as tunnel documentation.

Operational Organisation: Division of Responsibilities

14.7 Tunnel operational organisation has three main areas of responsibility: routine traffic management; equipment operation and its maintenance; rapid and coordinated emergency response. The details will depend on the individual tunnel and whether it is manned or unmanned. In manned tunnels, staff dedicated to work on tunnel equipment will be available, but many unmanned tunnels depend on traffic police operators to initiate action in connection with tunnel equipment, amongst their other duties.

14.8 The basis of tunnel organisation is shown in Chapter 2, Figure 2.4.

14.9 For each tunnel there shall be clear procedures and clearly defined responsibilities agreed and laid down, with respect to traffic management and tunnel equipment, to ensure rapid and coordinated response to emergencies.

Tunnel Traffic Management

14.10 The police Traffic Division will be responsible for the safe and efficient movement of the traffic through the tunnel, dealing with vehicle break-downs, traffic congestion and tidal flow (if used), escorting dangerous loads (if required) and managing traffic during tunnel maintenance (see Chapter 9).

Tunnel Equipment

14.11 The TOA will be responsible for the tunnel equipment, to maintain a safe environment for the tunnel users and maintaining such equipment in good working order (see Chapter 10).

Emergencies

14.12 An emergency will normally be detected by Traffic Control Centre from the CCTV monitors, traffic loops, incident detector alarms or the emergency roadside telephones. Traffic Control Centre are then

responsible for: the immediate summoning of the necessary emergency services; the immediate control of traffic entering the tunnel; alerting the TOA to provide necessary control of lighting, ventilation and pumping as required, and the setting up of diversions, traffic clearance measures and the issue of traffic information to minimise the effects of approach road congestion, in particular for dealing with the emergency.

14.13 Those responsible for the control of traffic passing through a tunnel will need to be aware of any changes in levels (status) of output from the equipment installed to control the tunnel environment, that is likely to lead to the development of an emergency condition. They will be responsible for responding to alarms that are raised at emergency points within the tunnel and within the tunnel services buildings. To undertake their respective responsibilities, the police, emergency services and TOA need a reliable supply of information and data. See below and Chapters 9, 10 and 13.

Information Systems

14.14 The Traffic Control Centre needs information and data to assess and respond to emergency conditions within the tunnel which will have an effect on traffic (eg alarm states for equipment and power), alarms raised by tunnel users at the emergency points (telephones, fire cabinets, micro-switches), routine traffic conditions within the tunnel or on its approaches, the needs of the emergency services, and overall security (eg tunnel services buildings).

14.15 The emergency services need information: to implement the agreed operating procedures in response to incidents and emergencies; on tunnel access arrangements (traffic control measures enforced by police); on the coordinated response between emergency services (before the emergency drill); on details of escape facilities, provisions made for them in plant and equipment (eg ventilation override), surveillance (CCTV), and communications with emergency service HQs (headquarters) and local facilities from the tunnel site.

14.16 The TOA needs data on ambient conditions concerning wind, luminance and general weather conditions, and the status of the equipment installed to control the tunnel environment (day-to-day demands, usage and running costs). It also needs information on: periodic inspection and maintenance requirements; factors that influence the optimum use of the tunnel installation and any corrective maintenance required (ie systems analysis); the support to be given to emergency

authorities (fire, breakdown, spillage); resource management (eg for energy conservation). See also Chapter 13.

Basis of Tunnel Operation

14.17 The day to day operation for traffic passing through a tunnel, or group of tunnels, will be administered from a Traffic Control Centre, which may be located at the tunnel or remotely.

14.18 A Traffic Control Supervisor or Duty Officer will normally be in charge of all operations and must be advised of any change in traffic or tunnel equipment operating conditions, by means of traffic surveillance and plant monitoring equipment. Most of this equipment will operate under localised automatic control and/or the telemetry system, and be monitored in the control room. The main functions to be carried out are to monitor, control and coordinate the traffic system, and to control the approach lighting, tunnel lighting, tunnel ventilation and any other equipment, as required.

14.19 In the event of ALARMS the Duty Officer must alert the staff concerned, up date any mimic, and generally monitor the status of all tunnel equipment and, in the event of a fire or traffic incident, take the required action, as laid down in the Police Control Centre Operators' Manual.

14.20 Support functions will be the responsibility of the TOA and include: tunnel cleaning and maintenance; clearance after Traffic Control Division have removed incident vehicles; repair and renewal of the technical operating equipment; maintenance repair and renewal of structural elements.

Normal Conditions (Free Flow)

14.21 In normal circumstances, traffic will be able to pass through a tunnel without stopping. However, to minimise incidents, reduce danger and ensure the best use of a tunnel, traffic may be controlled at times of peak flow. Any traffic stop signals provided shall operate automatically, under the control of road loops, and the phasing of the signals shall be set to be compatible with the general traffic flow. Where there is a tidal flow system, computer software shall be provided to assist in the correct sequencing of traffic signs at flow changeovers.

14.22 Normal traffic may include hazardous and abnormal loads. Any appropriate action such as escorting such loads is part of normal tunnel operation.

14.23 Tunnel ventilation fans are automatically controlled, as required by the levels of CO or visibility monitored by the appropriate sensors, and operated via the control system.

14.24 The tunnel lighting system is automatically controlled by a dawn/dusk timer and photo-electric cells as described in Chapter 6.

Emergency Conditions (Minor Incidents)

14.25 The majority of incidents, such as vehicle breakdowns, shunt accidents etc can be classed as “minor” and do not require more than the attendance of a “Traffic Officer” and a breakdown recovery vehicle. Traffic signing to close effected lanes and traffic control to deal with any build up of traffic congestion downstream will be required.

Emergency Conditions (Major Incidents)

14.26 A major incident may require a greater response, in terms of resources, than the normal response provided by the standard emergency procedures, and will involve the possibility of severe personal injury or loss of life, the risk of a serious fire or serious damage to property and serious disruption to the traffic flow with consequent exceptional delay. This subject is discussed in more detail in Appendix D.

14.27 During a major incident, the police have overall responsibility for the necessary intervention, under the control of the most senior police officer present. If a fire is involved, the fire aspects of the incident are the responsibility of the fire brigade under the control of the most senior fire officer present. Tunnel equipment should be operated by tunnel personnel, if available, who are familiar with the tunnel and its plant, under the direction of the police or fire incident officer, as appropriate.

Traffic Control

14.28 On receipt of an incident report, or the observation, say, of an incident on the CCTV monitors, which is considered to be a major incident then the following emergency procedures shall be put into action:

- i. Set traffic system to ALL TRAFFIC STOP to prevent traffic entering the tunnel(s).
- ii. Telephone all relevant emergency services and inform them of the type and likely severity of the incident. Advise if Fire and Ambulances services will be required.

- iii. Telephone to inform Police HQ, local to tunnel portals, and any Motorway Control Centres which may need to be involved.

Ventilation Control

14.29 The ventilation plant shall be first switched to manual, then fan and damper settings changed for smoke clearance to the predetermined regime appropriate to the location of the fire.

14.30 If fan settings are subsequently changed again by request from the Incident Fire Officer, details of time of request, revised fan settings and name of requesting officer shall be entered into the Control Point Log.

14.31 These actions shall be accommodated automatically by the data logging system described in Chapter 10.

Lighting Control

14.32 All the lighting stages of illumination would be switched to manual control to enhance the tunnel lighting, as necessary, and give all possible assistance to the emergency services, particularly in smoke conditions.

14.33 In the case of electrical power supply failure, a system of emergency lighting comprising approximately one in ten twin lamp luminaires, would be switched on from an Uninterruptible Power Supply (UPS). The UPS supply comprising batteries lasts for approximately two hours.

Additional Actions

14.34 Additional Actions to be taken during and following a major incident are set out in Appendix D.

Operational Staff Resources

14.35 Resources required by the Tunnel Operating Authority should differentiate between normal and emergency situations. Tunnel staff employed by the TOA should carry a dual responsibility ie for normal operating conditions, and for the additional responsibilities under emergency conditions. Appropriately trained and qualified staff shall be designated special responsibilities in the case of emergencies. Special responsibilities could include traffic control duties, emergency services call out, control of ventilation plant and power supplies and use of breakdown and recovery equipment.

14.36 Sometimes the operation of a road tunnel is carried out on a shared responsibility basis. Normally this responsibility will be divided between the Local Highway Authority who will take care of all work in connection with the roads and their maintenance and the Overseeing Organisation who will have responsibility for the tunnel structure and its equipment. Such a division of responsibility would occur when it is not economically feasible to provide a dedicated tunnel operating force. Irrespective of the shared roles, normal and emergency operating procedures will also need to be covered by the respective parties.

Safety Officer

14.37 A single member of staff shall be appointed as Safety Officer, responsible for all aspects of tunnel safety, with authority to obtain implementation of Safety Recommendations either directly, or immediately through the Tunnel Manager. The Safety Officer shall be responsible for the requirements of the Health and Safety at Work Act and the regulations made under its powers, such as the Control of Substances Hazardous to Health Regulations 1988. Responsibilities for safety supervision and its observance in the tunnel workplace must be accepted and applied by the whole of the workforce.

14.38 The Safety Officer shall be responsible for co-ordinating all aspects of handling emergency situations and traffic incidents including the effects and exposure limits of known pollutants and the effect of fire on materials which are likely to be transported through the tunnel. The Safety Officer shall have responsibilities for monitoring all arrangements for abnormal working of the tunnel and the performance of equipment to be used under emergency conditions.

14.39 The Safety Officer shall ensure that where potentially confined spaces such as ducts, service ways, sumps etc could be at risk from hazardous gases, liquid spills or seepage, there shall be a “gas free” check and permit to work issued, if safe, before any maintenance staff enter the space. Standard procedures on safe working practice shall be enforced and training provided to assist rescue from, and avoidance of, such potentially dangerous situations.

Authorised Staff

14.40 TOA maintenance staff shall comply with the Electricity at Work Regulations 1989, Health and Safety at Work Act 1974, the current IEE Regulations and any other relevant procedures issued by the TOA. A “permit to work” system shall be implemented for maintenance

on all electrical equipment. This allows only authorised tunnel staff, or outside contracting personnel, to repair or maintain plant and equipment, when it has been “locked” off electrically. HV systems must only be operated by Authorised Persons (APs) with appropriate training and certification, see Chapter 11.

Tunnel Maintenance

14.41 Maintenance will be carried out under the general provisions of the agreement with the Overseeing Authority. A tunnel shall be maintained and cleaned to high standards, during the short periods of lowest traffic flow. Lifetime expired equipment will need to be replaced at periodic intervals, and may require several weeks of continuing work. Tunnel lighting, for example, will require major work at the end of the selected burn-life of each set of lamps eg fluorescent lamps, at 50% burn on equal duty cycle, will require such work every 15 to 22 months (6000 - 8000 operating hours). Major tunnel refurbishments may be needed every 15 years or more and will require extensive planning and preparation.

14.42 This section shall be read in conjunction with the safety requirements of Chapter 2 and other Chapters describing particular specialist topics.

14.43 Whether maintenance is carried out by tunnel staff or term contractors, it is necessary to establish and specify, the levels of need and the quality of work required for the various types of maintenance to be carried out. It is most important to carry out the right maintenance at the right time and which minimises disruption to the travelling public. A whole life cost approach shall be used which avoids short term savings at the expense of higher longer term costs. A maintenance strategy shall be put in place by the TOA to meet such needs and which anticipates the likely extent of requirements, lane closure times available, noise and light pollution restraints, identification of any weak and vulnerable links in the system, need for contingency planning, availability of funding, relationships with manufacturers and term contractors, police etc.

14.44 The strategy should consider needs for flexibility to meet the unexpected and make changes in the light of experience, concentration of work into locational zones and specialist trades, expected times to complete each task, breaking down large tasks into smaller ones on a logical basis, concentration on repeated or extensive faults and their elimination, switching of items in-service to even out wear and tear, equipment component life expectancy, spares, specialist tools and equipment, needs

of access, communications, inspections, feedback, traffic management etc. Obsolescence should be considered, particularly in the case of electronic equipment. Newer equipment may be cheaper to install and more reliable than old, even if the older equipment is still functioning but is difficult to maintain, as specialists disappear and suppliers cease trading or product support. It may also prove cost effective to replace complex equipment with simpler equipment that has either less chance of failure or has a fail safe facility.

14.45 From the strategy established, maintenance planning objectives for the short, medium and long term can help in the decisions as to which items can be maintained on a daily, weekly, monthly, yearly, urgent or routine basis. Control of the maintenance process is by prioritisation, inspection, and recording.

14.46 The broad categories of road tunnel maintenance and inspection are as follows:

i. Corrective Maintenance,

objectives: Continuity of system operation, keeping the tunnel open and safe to use eg if a CO sensor fails and is not repaired the ventilation fans may not run, if a jet fan falls because its fixing bolts have vibrated loose, then the tunnel will be closed whilst all the remaining fixings are inspected.

by: Permanent or standby staff undertaking supervisory and overall inspection roles.

ii. Planned, Preventative Maintenance,

objectives: Preservation of investment, prevention of unscheduled closures, possibly for lengthy periods.

by: Term contractors, manufacturers' staff undertaking roles of regular specialist inspection, performance testing of equipment, calibration and cleaning. Overhauls will be to manufacturer's instructions. Systems testing of safety critical items (regular testing, auto diagnostics, continuous monitoring) eg traffic management, programmable logic controllers (data processing), communication systems.

iii. Technical Inspections, Special Inspections,

objectives: To ensure preservation of investment, planned and funded maintenance works and the continued safety of operation for the travelling public.

by: TOA coordinating the input of term contractors, manufacturers and other specialists, in accordance with BD53 (DMRB 3.1.6), IEE Wiring Regulations etc. Work is normally undertaken during a series of planned maintenance closures. Principal Inspections identify what works may be needed for the next 3/6 years.

iv. Major Overhaul and Refurbishment of the Tunnel Equipment and Tunnel Fabric,

objectives: To ensure long term preservation of investment by acting on the agreed recommendations of the Principal Inspection reports.

by: Specialist design consultants, contractors and manufacturers. Advantage will be taken of longer or more frequent closures periods, to replace in one go many items that have proved difficult to deal with during short term lane closures. A TDSCG will normally need to be set up for such works.

14.47 Prior to tunnel opening, a regular schedule for maintenance shall be established together with a plan of limited closures of the tunnel for planned minor maintenance.

Cleaning and Maintenance Schedules

14.48 Within the tunnel, walls, carriageways and drainage systems will all need to be cleaned regularly. Air ducts for tunnel ventilation and the entrances to fresh air supply ducts shall also be cleaned at regular intervals. Collections of tunnel dust can be a potential fire hazard and may contain heavy metals, asbestos and other pollutants from vehicles. Personal protective equipment is essential. Specialised and articulated, mechanical rotating brush and spray jet equipment is available or can be manufactured to suit particular tunnel geometries. Care is needed that over-vigorous cleaning does not remove the protective systems of equipment against corrosion.

14.49 Cleaning and maintenance shall be carried out at least once per week. A typical tunnel maintenance schedule is shown in Figure 14.1.

14.50 Manuals (specified in Chapter 13) will have been prepared for the instruction and guidance of the Tunnel Operation Authority in carrying out specific maintenance functions within the tunnel.

Inspection and Testing

14.51 An inspection and testing programme shall be established which will include examination of the tunnel structure, quantitative measurements of light output, vibration of rotating machinery, and failure rate against hours run etc, all logged on a regular basis, as described in Chapter 10. BD53 (DMRB 3.1.6) gives details of inspection types and reporting records. The inspection types are purposely intended to lead to no surprises and consequent unplanned closures for emergency repairs.

14.52 Isolated items of equipment may often fail in their very early life. These items will be replaced within the Maintenance Period. Certain items will need to be inspected to meet the timing requirements of eg IEE, other items which prove to be troublesome will need increased frequencies of inspection, or whole scale replacement. For items which are large in number or present difficulties from the point of view of available time to access them, such as items behind secondary cladding panels, then the number of items to inspect over each year can be estimated from the normal distribution curve (NDC), see Figure 14.2. If the mean time to failure (MTF) of an item is taken to be 3 standard deviations (SD) then from time zero (new) all items must be inspected at increasing numbers per year so that all (100%) are inspected by the time the MTF year is reached. For example, if MTF is 9 years, then 4.28%, 27.46% and 68.26% of items must be inspected, on a random basis, in each of the respective three 3 year periods from time zero. This method allows resources to be concentrated into the latter years when proportionally more failures could be expected to occur.

Lane Closures

14.53 Lane closures and use of cross overs may be required when carrying out maintenance and inspection within a tunnel. Lane closures etc by means of gantry signals shall be supplemented by additional signing, cones etc in accordance with Chapter 8 of the Traffic Signs Manual. PIARC C5 Report: Brussels 1987: I.2 - Signing in the Case of Work Inside Tunnels gives illustrations of sign and cone layouts for fixed, alternated and mobile worksites. Police assistance may be invaluable during the onerous and dangerous temporary signing process in assisting to reducing the danger from traffic at lane closing/opening stages and in "enforcing" speed limits. Automatic lane closure barriers (by progressive unfolding in conjunction with signals) are used successfully in Europe but are believed not to be legal under the current Highways Act. Animated retroreflective dummies waving red flags at potential danger spots have also been successfully used Overseas.

Plans shall include sufficient time for the set up/put away times for traffic management and the effect on available productive maintenance working times.

14.54 The TOA will normally need to arrange lane closures in liaison with the affected Local Highway Authorities and include for alternative routes. A website detailing lane closures is available at <http://www.highways.gov.uk/>. Local media may also need to be informed. The relevant Traffic Orders shall be in place for carriageway closures.

Traffic Control During Maintenance

14.55 The maintenance workforce shall be protected from the traffic and the traffic from the works. Traffic Control Supervisors or Duty Officers will require minimum disturbance to traffic during periods of maintenance. Such requirements lead to the creation of special traffic conditions during maintenance works, involving single lane restrictions or closures, depending upon the scale of the work and the layout of the tunnel. The equipment used directly to control the traffic shall include the lane control signals and lane segregation signs on overhead gantries, working in conjunction with Variable Message Signing, as provided.

14.56 Traffic within a tunnel can produce noise levels in excess of 95dB(A). Traffic also produces turbulent air conditions, greater than the open air, which with positive and negative (suction) pressures and other air speed hazards can unbalance those on foot or working at height. Projections from vehicles can hit workers or unbalance working platforms etc. The workforce may not be sufficiently protected, when working in a closed lane of a bore, if vehicle speeds are not physically restricted in the remaining running lanes. A system of platooning, by grouping vehicles together and guiding them through the tunnel at slow speed (say 15 mph) with a lead vehicle, will enable air velocities to be limited and allow maintenance to be carried out safely whilst maintaining at least some traffic flow through the bore. An angled temporary concrete barrier, or equivalent shield (traffic management) vehicle (unoccupied and 30m minimum from workers) placed just inside of the relevant portals can protect against vehicle drivers who may still attempt to enter a closed tunnel bore or lane, in error. It shall be recognised that some safety items may be temporarily out of operation during the maintenance works. It is preferable to work on equipment in workshops away from the tunnel.

Radio communications

14.57 Radio communications allow rapid coordination and response in the event of an incident, with communications direct to the Traffic Control Centre.

Equipment Settings During Maintenance

14.58 During maintenance conditions, the lighting and ventilation may have to be enhanced so that staff can work in safety and efficiently. Pollution levels will be higher if any traffic is permitted to stop/start. It is usual to provide maximum approach/tunnel lighting during maintenance works.

14.59 Where conditions warrant, the ventilation plant shall be switched to manual. The lighting shall be switched to manual control and extra stages of lighting used to increase the lighting levels. The usage of luminaires shall be arranged to give continuity of lighting throughout the length of the tunnel.

Access and Safety Procedures

14.60 All staff and contractors involved with entering the tunnel shall be issued with, and abide by, the rules and procedures of tunnel operations, including lane and tunnel closures - all of which shall be clearly stated and be expressed simply. All shall be familiarised with the tunnel site layout. A system of recorded signatures for receiving such information is advisable. The working route of an inspector (as with all persons working in a tunnel) shall be recorded and a system provided to verify return. If access is required to an enclosure a second man shall be present. A driver will be needed for transit through an operational tunnel.

14.61 Maintenance Staff shall notify the appointed Tunnel Controller before entering and immediately after leaving the tunnel environs and provide details of any work which may affect the traffic or tunnel services. Tunnels with mechanical ventilation can purge the tunnel bores etc of vehicle pollution prior to entry by staff. Tunnels with natural ventilation may need time to clear and readings of CO, NO₂ etc shall be taken using personal gas monitors prior to entry of any section of the tunnel.

14.62 Services Building entry doors will normally be protected by Intruder Alarm Systems. Maintenance staff will therefore need to switch off the alarm system on entering the building and re-activate it on leaving.

14.63 Maintenance staff will notify the Tunnel Controller before entering a halon or Co₂ protected room and "lock off" the fire extinguishing system. They shall reverse the procedure on leaving.

FIGURE 14.1: Typical Maintenance Schedule

Item	Equipment	Cleaning Frequencies	Maintenance Frequencies
1	Lamps	1 - 2 months	8 - 36 months
2	Lighting controls	12 months	12 months
3	Jet fan overhaul		48 months
4	Axial flow fans and auxiliary equipment		Minor: 4000 hours Major: 25000 hours
5	Obscuration meters	1 month	Minor: 1 month Major: 12 months
6	CO monitors	3 months	3 - 12 months
7	Anemometers		6 months
8	Ventilation computer	1 month	1 month
9	Ventilation switch gear	24 months	12 months
10	Remote control system		6 months
11	Lights	1 week - 3 months	6 months
12	Variable message signs	6 months	12 months
13	Safety barriers		6 months
14	Movable barriers		6 months
15	Traffic recording/induction loops		3 - 12 months
16	Traffic computer	6 months	1 month
17	Peripheral units	6 months	6 months
18	Emergency phones	1 month	3 months
19	Fire Hydrants in tunnel recesses	6 months	6 months
20	Hand fire extinguishers	6 months	12 months
21	Fire hydrant main		6 months

Item	Equipment	Cleaning Frequencies	Maintenance Frequencies
22	Automatic fire alarm system		3 months
23	CCTV cameras and equipment	1 month	1 month
24	Public address loudspeaker system		6 months
25	Radio system	12 months	6 months
26	Overheight vehicle detectors		6 months
27	Escape doors and tunnel walls	See Chapter 6	6 months
28	Transformers		12 months
29	HV switch gear	12 months	12 months
30	LV switch gear	24 months	12 months
31	Emergency switch gear and UPS systems	12 - 24 months	1 - 3 months
32	Batteries	1 week	1 - 12 months
33	Gulleys	1 month	
34	Sumps	1 month	
35	Foul sumps	1 - 3 months	
36	Oil and petrol separators	1 month	
37	Pumps	1 week	1 month
38	Pump controls	1 week	1 month
39	Valve actuators	1 week	1 month
40	Road Surfacing	1 week	Minor: 1 month Medium: 12 months Major: 7-10 years

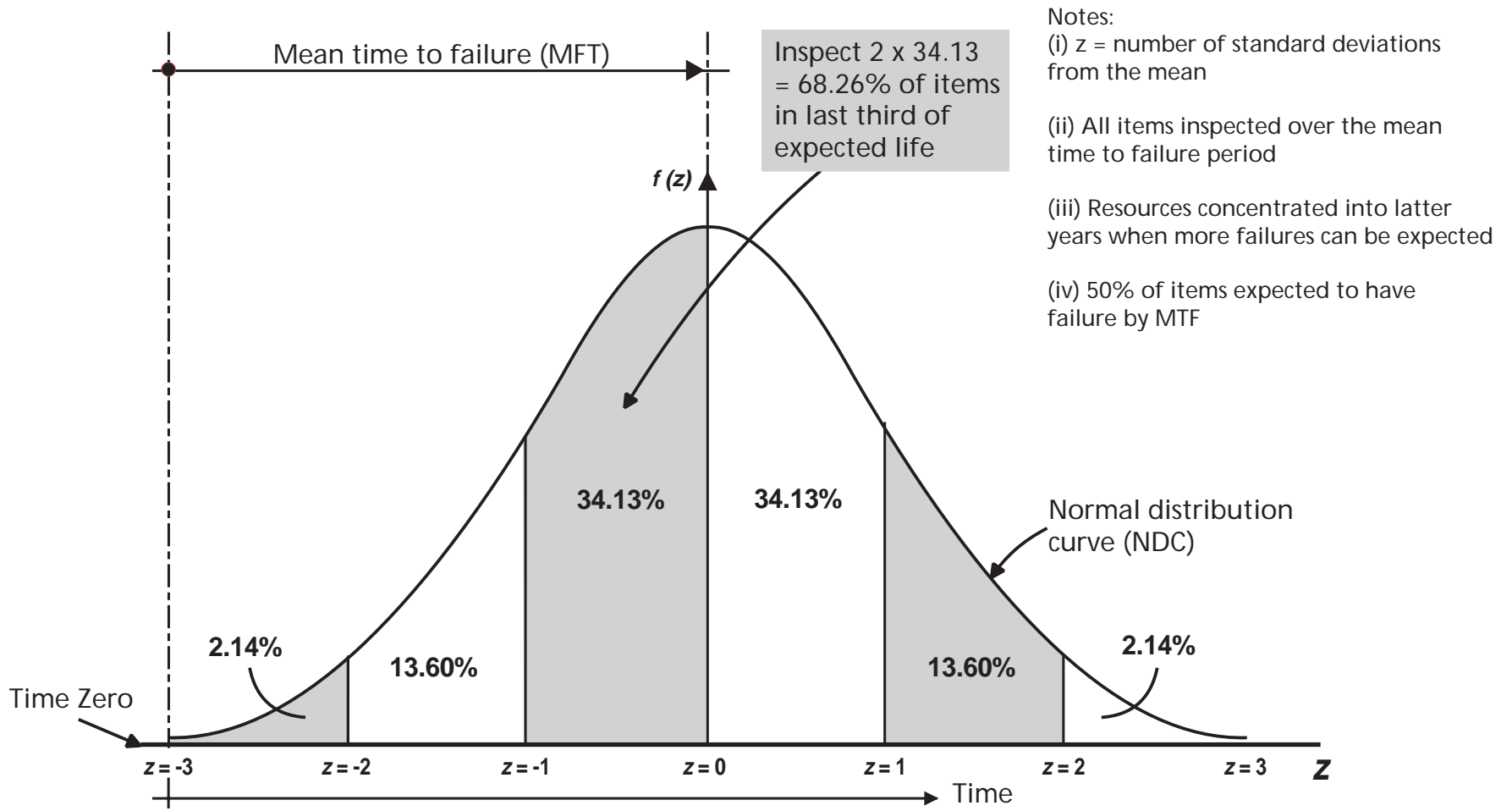

Figure 14.2

Number of Items to Inspect with Time

15. REFERENCES AND GLOSSARY

General

15.1 This Chapter provides, in chapter order, a list of references and a glossary of common abbreviations. Unless specifically referred to within the other Chapters and Appendices of this Standard or a published document of the Overseeing Organisation such reference documents are intended for information and guidance only and may not be taken to reflect the current policy of the Overseeing Organisations. Documents will from time to time be updated or superseded and Design Organisations shall ensure that they are working to the most current versions. See also Appendix E.

15.2 Departmental Standards of the DMRB (Design Manual for Roads and Bridges) and Manual of Contract Documents for Highway Works are published by the Highways Agency and may be obtained from the Stationary Office Publications Centre, PO Box 276, LONDON SW8 5DT, United Kingdom (General Enquiries: telephone +44 (0)171 873 0011, +44 (0)171 873 8247 fax).

15.3 World Road Association PIARC documents may be obtained from British PIARC Secretariat, Room 4/79, St Christopher House, Southwark Street, LONDON SE1 0TE, United Kingdom (telephone +44 (0)171 921 4349, +44 (0)171 921 4505 fax).

15.4 Publications and reports of TRL (Transport Research Laboratory) may be obtained from TRL Library Services, Old Wokingham Road, Crowthorne, Berkshire, RG45 6AU, United Kingdom (telephone +44 (0)1344 770783/4, +44 (0)1344 770193 fax).

15.5 Publications of the Health and Safety Executive may be obtained from HSE Books, PO Box 1999, Sudbury, Suffolk CO10 6FS, United Kingdom (telephone +44 (0)1787 881165, +44 (0)1787 313995 fax).

15.6 Publications of the British Standards Institution may be obtained by writing to BSI, Lindford Wood, Milton Keynes, MK14 6LE, United Kingdom.

15.7 Publications of CIRIA (Construction Industry Research and Information Association) may be obtained from CIRIA, 6 Storey's Gate, Westminster. LONDON SW1P 3AU, United Kingdom (telephone +44 (0)171 222 8891, +44 (0)171 222 1708 fax,

EMAIL switchboard@ciria.org.uk,
WEBSITE www.ciria.org.uk).

15.8 REFERENCES

Chapter 1. Introduction

Overseeing Organisation Publications

- i. Manual of Contract Documents for Highway Works: Volume 5 Contract Documents for Specialist Activities: Section 7 Mechanical and Electrical Installations in Road Tunnels, Movable Bridges and Bridge Access Gantries.

Other publications

- i. The First Road Tunnel: PIARC Committee on Road Tunnels: 1995.
- ii. Tunnel Vision?: The Future Role of Tunnels in Transport Infrastructure: Parliamentary Office of Science and Technology: January 1997: ISBN 1 897941 36 6.

Chapter 2. Planning, Safety, General Design Considerations

Overseeing Organisation Publications

- i. Departmental Standard BD2 (DMRB 1.1) Part III - The Technical Approval of Highway Structures on Motorways and Other Trunk Roads: Procedures for Tunnels
- ii. Departmental Standard BD21 (DMRB 3.4.3) - The Assessment of Highway Bridges and Structures
- iii. Departmental Standard BD31 (DMRB 2.2) - Buried Concrete Box Type Structures
- iv. Departmental Standard BD37 (DMRB 1.3) - Loads for Highway Bridges
- v. Departmental Standard BD42 (DMRB 2.1.2) - Design of Embedded Retaining Walls and Bridge Abutments (Unpropped or Propped at the Top)

- | | |
|--|--|
| <ul style="list-style-type: none"> vi. Departmental Standard BD43 (DMRB 2.4) - Criteria and Materials for the Impregnation of Highway Structures vii. Departmental Standard BD47 (DMRB 2.3.4) - Waterproofing and Surfacing of Concrete Bridge Decks viii. Departmental Standard BD53 (DMRB 3.1.6) - Inspection and Records for Road Tunnels ix. Departmental Advice Note BA80 (DMRB 2.1.7) - Design of Rock Bolts x. Departmental Standard HD13 (DMRB 4.1) - Documentation Requirements for Ground Investigation Contracts xi. Departmental Standard HD22 (DMRB 4.1.2) - Ground Investigation and Earthworks Procedure for Geotechnical Certification xii. Departmental Advice Note HA34 (DMRB 4.1) - Ground Investigation Procedure xiii. Departmental Advice Note HA73 (DMRB 4.1.7) - Site Investigation for Highway Works on Contaminated Land xiv. Departmental Standard HD19 (DMRB 5.2.2) - Road Safety Audits xv. Departmental Advice Note HA42 (DMRB 5.2.3) - Road Safety Audits xvi. Departmental Standard TD20 (DMRB 5.1) - Traffic Flows and Carriageway Width Assessment xvii. Departmental Advice Note TA46 (DMRB 5.1.3) - Traffic Flows and Carriageway Width Assessment for Rural Roads xviii. HA Health and Safety Notices, Volume 1: Staff Site Safety Manual. Notice No.9 - Working in Confined Spaces xix. HA Health and Safety Notices, Volume 1: Staff Site Safety Manual. Notice No.10 - Working in Tunnels xx. HA Health and Safety Notices, Volume 1: Staff Site Safety Manual. Notice No.11 - Staff Working with Lighting Equipment and Electrical Services on Roads and in Tunnels. | <p><i>British Standards</i></p> <ul style="list-style-type: none"> i. BS 1449, Part 2: 1983 - Specification for Stainless and Heat-resisting Steel Plate, Sheet and Strip ii. BS 5266, Part.1: 1975 - Code of Practice for the Emergency Lighting of Premises other than Cinemas and Certain other Specified Premises used for Entertainment iii. BS 5400 - Steel, Concrete and Composite Bridges, All Parts but in particular, Part 1: 1988 - General Statement; Part 2: 1978 - Specification for Loads; Part 3: 1982 - Code of Practice for Design of Steel Bridges; Part 4: 1990 - Code of Practice for Design of Concrete Bridges; Part 5: 1979 - Code of Practice for Design of Composite Bridges. All as implemented by respective separate documents of the DMRB (Design Manual for Roads and Bridges). iv. BS 5839 - Fire Detection and Alarm Systems for Buildings, Part 1: 1988 - Code of Practice for System Design, Installation and Servicing v. BS 6164: 1990 - Code of Practice for Safety in Tunnelling in the Construction Industry vi. BS 7671: 1992 - Requirements for Electrical Installations, IEE Wiring Regulations, Sixteenth Edition. <p><i>TRL (Transport Research Laboratory) Contractor Reports</i></p> <ul style="list-style-type: none"> i. CR41: Planning and Design Considerations for Road Tunnels: The Influence of Operation and Maintenance. S T Jones, G Fudger ii. CR51: Some Considerations Affecting the Selection of Tunnelling Methods. I W Farmer iii. CR63: A Study of the Operating Costs of Road Tunnels in the United Kingdom. A M Rossell, B R Pursall iv. CR124: Comparison of Predicted and Measured Performance of the Retaining Walls of the Bell Common Tunnel. K G Higgins, D M Potts, I F Symons v. CR139: Risk Assessments of the Transportation of Hazardous Substances Through Road Tunnels in the United Kingdom. M Considine, S T Parry, K Blything |
|--|--|

- vi. CR252: Study of Costs of Cut and Cover Tunnel Construction. A R Umney, D Miller
- vii. CR265: Finite Element Analyses of Settlement Above a Tunnel in Soft Ground. R J Mair, D W Hight, D M Potts.

TRL Laboratory Reports

- i. LR326: A Preliminary Study of the Cost of Tunnel Construction. G Margason, R G Pocock
- ii. LR714: The Particle Size Distributions of Debris Produced During Tunnelling Trials. A F Toombs, R A Snowdon, M P O'Reilly
- iii. LR740: A Guide to Site Investigation Procedures for Tunnels. M J Dumbleton, G West

TRL Published Papers

- i. Prospects of Urban Highways in Tunnels. M P O'Reilly, A P Munton. ICE Transportation Engineering Conference, pp 43-53, 1972
- ii. Sub City Tunnels. M P O'Reilly. Civil Engineering, Oct 1975
- iii. Transport Tunnels in Urban Areas. M P O'Reilly. Journal Institution Highway Engineers, Jan 1976
- iv. Cost Factors for Cut and Cover Tunnels. A R Umney, D Miller, D R Carder. Tunnelling '91, Institution of Mining and Metallurgy, London, pp 313-327, 1991.
- v. Tunnelling Induced Ground Movements: Predicting their Magnitude and Effects. B M New, M P O'Reilly. International Conference on Ground Movement and Structures, Cardiff, Vol 4, pp 671-697, July 1991
- vi. Ground Vibrations Caused by the Construction and Operation of Transport Systems. G I Crabb, B M New, D M Hiller. Proceedings 3rd International Symposium on Field Measurements in Geomechanics, Oslo, pp 443-454, 1991
- vii. Environmental Impacts of Tunnel Construction. D M Hiller, K H Bowers. Proceedings of The Chartered Institution of Water and Environment Management, South Western Branch, Centenary Symposium, Tunnelling In The Water Industry.

TRL Supplementary Report

- i. SR335: A Review of Tunnel Lining Practice in the United Kingdom. R N Craig, A M Muir Wood.

TRL Project Reports

- i. PR89: The Design, Construction and Instrumentation of The Pen-Y-Clip Section of The A55, North Wales Coast Road. K C Brady, D A Barratt and P J Selley
- ii. FEHRL 2: Analysis of The Submerged, Floating Tunnel Concept
- iii. PR280: Ground classification systems in tunnel construction. G I Crabb
- iv. TRL Report 379: Performance during construction of a cut-and-cover tunnel founded in London Clay at Edmonton (A406 Fore Street Tunnel). D R Carder, K J Barker, M R Easton.

Other Documents

- i. CIRIA Report 44 - Medical Code of Practice for Work in Compressed Air: 1982
- ii. CIRIA Report 81 - Tunnel Waterproofing (withdrawn)
- iii. Statutory Instrument 1958 No. 61 - Work in Compressed Air Special Regulations
- iv. Statutory Instrument 1989 No. 635, Health and Safety - Electricity at Work Regulations
- v. Health and Safety Executive, Guidance Note EH40: Occupational Exposure Limits. (Updated annually).
- vi. DISC PD2000-1:1996 - A Definition of Year 2000 Conformity Requirements (BSI)
- vii. Research on Tunnels at the Transport and Road Research Laboratory. M P O'Reilly. Underground Services, Vol 3, No 4, 1975
- viii. Recent Research in the United Kingdom on the Operation of Road Tunnels. M P O'Reilly, G R Fellowes. Tunnel Management: Economics, Environment and Safety, Lugano, Switzerland, Seminar RT2, Nov 1990

ix. TRL Working Paper No.14: Tunnelling Research in the UK. Hudson.

x. Road Safety in Tunnels: PIARC Committee on Road Tunnels: 1995

Chapter 3. Operational Classification of Safety Facilities for the Road User

World Roads Association PIARC

i. PIARC XVIIIth World Road Congress, Brussels 1987. Technical Committee Report No. 5 - Road Tunnels, Section 1.1.1 - Safety Equipment

ii. PIARC XXth World Road Congress, Montreal 1995. PIARC Committee on Road Tunnels: Supplementary Paper on Classification of Tunnels, Existing Guidelines and Experiences, Recommendations.

Overseeing Organisation Publications

i. Departmental Report MCH 1745 A, Issue 03: August 1994. Hazards of Traffic Management within Tunnels

ii. The Value for Money Manual, Highways Agency, June 1996.

Chapter 4. Tunnel Geometric Design for Traffic

Overseeing Organisation Publications

i. Departmental Standard TD9 (DMRB 6.1.1) - Highway Link Design

ii. Departmental Standard TD20 (DMRB 5.1) - Traffic Flows and Carriageway Width Assessment

iii. Departmental Standard TD27 (DMRB 6.1.2) - Cross Sections and Headrooms

iv. Traffic Appraisal of Roads Schemes (DMRB 12.1) - The Traffic Appraisal Manual (TAM), August 1996.

TRL Supplementary Report

i. SR455: Speed/Flow Relationships in Road Tunnels. A P Bampfylde, G J D Porter, S D Priest.

Chapter 5. Ventilation

i. Permanent International Association of Road Congresses (PIARC), XXth World Road Congress, Montreal, Sept. 1995. Report of Committee C5 on Road Tunnels, Part II - Pollution, Environment, Ventilation

ii. Permanent International Association of Road Congresses (PIARC) Technical Paper: Road Tunnels - Emissions, Ventilation, Environment, 1995

iii. World Health Organisation (WHO). Air Quality Guidelines for Europe, WHO Regional Publications, European Series No. 23, 1988

iv. Health and Safety Executive Guidance Note EH40: Occupational Exposure Limits. (Updated annually)

v. Department of Transport, Vehicle Standards and Engineering Division. Fact Sheet No. 1, Issue 3, Sept. 1995: In-Use Vehicle Emissions Standards Applicable from September 1995

vi. Department of Transport, Vehicle Standards and Engineering Division. Fact Sheet No. 2, Issue 3, Sept. 1995: In-Use Vehicle Emissions Standards; Supplementary Requirements Applicable from 1 January 1996

vii. Road Vehicles (Construction and Use) Regulations 1986, Regulation 61 ("First Use" requirements for new vehicles) and Supplementary Instruments

viii. TRL Contractor Report 136: Vehicle Emission Experimental Study. J F L Lowndes, A West, P J Martin

ix. TRL Laboratory Report 477: A Review of Methods of Ventilating Road Tunnels. H J Hignett, L Hogbin

x. World Roads Association, PIARC Committee on Road Tunnels: Fire and Smoke Control in Road Tunnels, 1999

xi. DMRB (11.3.1) Environmental Assessment: Air Quality.

Chapter 6. Lighting

British Standards

- i. BS5489, Part 7: 1992 - Code of Practice for the Lighting of Tunnels and Underpasses
- ii. BS5266, Part.1: 1975 - Code of Practice for the Emergency Lighting of Premises other than Cinemas and Certain other Specified premises used for Entertainment

Commission International d'Eclairage (CIE) Publications

- i. CIE30.2:1982 - Calculation and Measurement of Luminance and Illuminance in Road Lighting
- ii. CIE66:1984 - Road Surfaces and Lighting (Joint Technical Report CIE/PIARC).

Chapter 7. Drainage

- i. Highways Act 1980. London : HMSO, 1980. (In Scotland: Roads (Scotland) 1984)
- ii. Health and Safety at Work etc Act 1974. London : HMSO, 1974
- iii. Public Health Act 1936. London : HMSO, 1936
- iv. Design and Analysis of Urban Drainage: Wallingford Procedure, Volume 4 Modified Rational Method. London, National Water Council, 1981
- v. A Guide for Engineers to the Design of Storm Sewer Systems. Department of the Environment Road Note 35, 2nd Edition. London, HMSO, 1976
- vi. Russam, K. Hydraulic Efficiency and Spacing of BS Road Gulleys TRRL Report LR277. Crowthorne, TRRL 1969
- vii. The Drainage Capacity of BS Road Gullies and a Procedure for Estimating their Spacing. TRRL CR2 "Hydraulics Research Station Report EX1118" Crowthorne TRRL 1984
- viii. BS 5345 : Part 2 : 1983. Code of Practice for Selection, Installation and Maintenance of Electrical Apparatus for use in Potentially Explosive Atmospheres (other than mining applications or explosive processing and manufacture) : Part 2 Classification of Hazardous Areas.

Overseeing Organisation Publications

- i. Departmental Advice Note HA71 (DMRB 4.2.1) - The Effects of Highway Construction on Flood Plains
- ii. Departmental Standard HD33 (DMRB 4.2.3) - Surface and Sub-surface Drainage Systems for Highways
- iii. Departmental Standard BD2 (DMRB 1.1) Part III - The Technical Approval of Highway Structures on Motorways and Other Trunk Roads: Procedures for Tunnels.

Additional Information

- i. Water Practice Manual. IWE&S.
- ii. Meteorological Office Records (Precipitation).

Chapter 8. Fire Safety Engineering

- i. Home Office Technical Bulletin 1/1993: Operational Incidents in Tunnels and Underground Structures: HMSO (now SO).
- ii. Fire Risk Assessment: Complying with the Fire Precautions (Workplace) Regulations 1997: Fire Industry Council
- iii. BS 476 1970 Fire Tests on Building Materials and Structures Part 4 - Non Combustibility Test for Materials. London: BSI. BS Standards (various) for flammability and fire testing.
- iv. The Building Regulations 1991 Approved Document Part B Fire, Safety. London : HMSO, 1992, ISBN 0 11 7523135
- v. Montreal Protocol on Substances that Deplete the Ozone Layer
- vi. Studies of Fire and Smoke Behaviour Relevant to Tunnels. Heselden, A.J.M. Paper J1, Second International Symposium on the Aerodynamics and Ventilation of Vehicle Tunnels. Cranfield : BHRA, 1976.
- vii. Major Hazard Aspects of the Transport of Dangerous Substances: Advisory Committee on Dangerous Substances: Health & Safety Commission: 1991, HMSO (now SO). Appendix 13 covers emergency planning.

- viii. Fire in Road Tunnels: Protection for civil engineering structures, electrical circuits and equipments: WRA (PIARC) Routes/Roads, No 275, III: 1991.
- ix. Road Safety in Tunnels: PIARC Committee on Road Tunnels: 1995
- x. British Standards, or equivalent, where relevant to road tunnels and service buildings:

BS AU 169: Burning behaviour of road vehicles (internal materials) etc.
BS EN 671-1: Fixed fire fighting systems. Hose systems.
BS ISO 10294: Fire resistance tests. Fire dampers for air distribution systems.
BS 5041: Fire hydrant systems equipment.
BS 5306: Fire extinguishing installations and equipment on premises.
BS 5588: Fire precautions in the design, construction and use of buildings.
BS 5810: Code of Practice for access for the disabled to buildings.
BS 7273: Code of Practice for the operation of fire protection measures
BS 7346: Components for smoke and heat control systems.

DD 233: Code of Practice for gaseous fire fighting systems.
DD 240: Fire safety engineering in buildings.
- xi. See also Chapters 10, 11 & 12 references.

TRL Contractor Reports

- i. TRL Contractor Report No.28: Mathematical Modelling of Fire in Road Tunnels - Validation of Jasmine. S Kumar, G Cox
- ii. CR101: Mathematical Modelling of Fire in Road Tunnels - Effects of Radiant Heat and Surface Roughness. S Kumar, G Cox.

Chapter 9. Traffic Control, Communications and Information Systems

Overseeing Organisation Publications

- i. Departmental Standard BD2 (DMRB 1.1) - The Technical Approval of Highway Structures for Motorways and other Trunk Roads - Part III Tunnels.

Overseeing Organisation Specifications

- i. Manual of Contract Documents for Highway Works: Volume 5 Contract Documents for Specialist Activities: Section 7 Mechanical and Electrical Installations in Road Tunnels, Movable Bridges and Bridge Access Gantries
- ii. MCE 2108 - 620 Cabinets for BT Interfaces
- iii. MCE 2122 - Active Infra Red Above Ground Vehicle Detectors
- iv. MCF 2336 - Tunnel Sub System
- v. MCH 1745 - Hazards of Traffic Management within Tunnels
- vi. TR 2029 - Inductive Loop Cable for Vehicle Detection Systems
- vii. TR 2031 - Armoured Feeder Cable for Inductive Loop System
- viii. TR 2095 - NMCS2 Variable Message Sign Driver
- ix. TR 2124 - (Draft) Specification for Automatic Incident Detection Systems Outline System Specification
- x. TR 2125 - Specification for Automatic Incident Detection Systems Outline Installation Specification
- xi. TR 2136 - Functional Specification for Continuous or Discontinuous VMS
- xii. TR 2144 - NMCS2 MIDAS Subsystem Specification
- xiv. TR 2147 - Microwave Vehicle Detection equipment for Portable Vehicle Actuated Traffic Signals
- xv. TR 2148 - Outline Specification for CCTV Alert System
- xvi. TR 2166 - NMCS2 Traffic Counting Subsystem Specification
- xvii. TR 2174 - NMCS2 MIDAS System Performance Specification
- xviii. TR2177 - NMCS2 MIDAS Outstation Algorithm Specification

ixx. TR 2178 - NMCS2 MIDAS Interface Specification.

Other Documents

- i. The Traffic Signs and General Directions Regulations HMSO
- ii. Planning and Design Considerations for Road Tunnels: The Influence of Operation and Maintenance. Crowthorne: TRRL Contractor Report 41
- iii. European Community Directive 89/376/EEC
- iv. International Electrotechnical Commission - IEC - 1508
- v. International Electrotechnical Commission - IEC - 332-2
- vi. International Electrotechnical Commission - IEC - 332-3
- vii. Institute of Electrical and Electronic Engineering IEEE - 383
- viii. Radio Communications Agency Publication RA 133
- ix. Radio Communications Agency Publication MPT 1367
- x. Radio Communications Agency Publication MPT 1510.

Chapter 10. Plant Monitoring and Control

- i. Departmental Standard BD53 (DMRB 3.1.6) - Inspection and Records for Road Tunnels
- ii. TRL Supplementary Report No.833: The Application of Microelectronics to the Control of Highway Tunnels. H J Bennett, M F Chudleigh, M P Halbert, G K A Oswald.
- iii. BS EN 60695: Fire hazard testing

Chapter 11. Electrical Power Supply and Distribution

- i. BS7671:1992 - Requirements for Electrical Installations, IEE Wiring Regulations, Sixteenth Edition

ii. Statutory Instrument 1989 No. 635, Health and Safety - Electricity at Work Regulations.

iii. Guidance Note 4 of IEE Wiring Regulations on protection against fire.

iv. BS 4066: Tests on electric cables under fire conditions.

v. BS 6425: Tests on gases evolved during the combustion of materials from cables.

v. BS 6387: Specification for performance requirement for cables required to maintain circuit integrity under fire conditions (< 750 volts).

Chapter 12. Services Buildings and Plant Rooms

- i. The Building Regulations 1985. London: HMSO SI 1985 No.1065,1985
- ii. BS6651:1992 - Code of Practice for the Protection of Structures Against Lightning.
- iii. See Chapter 8, 10 & 11 references.

Chapter 13. Tunnel Commissioning, Handover and Tunnel Documentation

- i. Manual of Contract Documents for Highway Works: Volume 5 Contract Documents for Specialist Activities: Section 7 Mechanical and Electrical Installations in Road Tunnels, Movable Bridges and Bridge Access Gantries
- ii. Departmental Standard BD53 (DMRB 3.1.6) - Inspection and Records for Road Tunnels.

Chapter 14. Tunnel Operation and Maintenance

- i. Health and Safety at Work Act 1974
- ii. Electricity at Work Regulations 1989
- iii. The Control of Substances Hazardous to Health (COSHH) Regulations 1988
- iv. Planning and Design Consideration for Road Tunnels : The Influence of Operation and Maintenance S. T. Jones & G. Fudger, Department of Transport, TRRL, CR41 (1988)
- v. Guidelines to Set Up Instructions in Case of Fire in Road Tunnels. PIARC Technical Committee on Road Tunnels, Working Group Operation - Maintenance - Management, 15 March 1990.

- vi. Dartford Tunnel Controllers Manual, Vol. 2: Emergency Procedures, Mott Hay and Anderson
- vii. M25 Holmesdale Tunnels, Operation Manual (Metropolitan Police), Mott, Hay and Anderson.

Chapter 15. References and Glossary

No additional references.

Appendix A - Secondary Cladding

No references.

Appendix B - Durability and Materials

- i. BS 5493:1977 - Code of Practice for Protective Coating of Iron and Steel Structures Against Corrosion
- ii. Specification for Protection of Highway Works, Series 1900 6th Edition, and Notes for Guidance
- iii. BS Code of Practice 1021 for Cathodic Protection.

Appendix C - Tunnel Documentation: Typical Contents

No references.

Appendix D - Guidelines for Major Incident Operations and Fire Tests

Additional Information

- i. Guidelines to Set up Instructions in the Case of Fire in Road Tunnels, PIARC Technical Committee on Road Tunnels, Working Group Operation - Maintenance - Management, 15 March 1990.
- ii. Heselden, A.J.M., Studies of Fire and Smoke Behaviour Relevant to Tunnels. Paper J1, Second International Symposium on the Aerodynamics and Ventilation of Vehicle Tunnels. Cranfield: BHRA, 1976.
- iii. Home Office Technical Bulletin 1/1993: Operational Incidents in Tunnels and Underground Structures: HMSO (now SO).
- iv. Major hazard aspects of the transport of dangerous substances: Advisory Committee on Dangerous Substances: Health & Safety Commission: 1991, HMSO (now SO). Appendix 13 covers emergency planning.

Appendix E - Recent Research by the Highways Agency

No additional references.

Appendix F - Tunnel Design and Safety Consultation Group (TDSCG) Requirements

- i. See Appendix D references.
- ii. BD2 (DMRB 1.1): Technical Approval of Highway Structures on Motorways and Other Trunk Roads: Part III: Procedures for Tunnels.
- iii. BD53 (DMRB 3.1.6): Inspection and Records for Road Tunnels.

Appendix G - Life Expectancy of Tunnel Equipment

No references.

15.9 GLOSSARY OF TERMS

TERM/ABBREVIATION	MEANING
AADT	Annual Average Daily Traffic
ACB	Air circuit breaker
AFFF	Aqueous Film Forming Foam
AIP	Approval In Principle document
ASTA	Association of Short Circuit Testing Authorities
AWA	Aluminium Wire Armoured
BA	Bridges Advisory, Similarly HA (Highways), TA (Traffic)
BBC	British Broadcasting Corporation
BD	Bridges Directive, Similarly HD (Highways), TD (Traffic)
BS	British Standard
BSI	British Standards Institution
Cavitation	A physical combination of vapour (and liquid) forming on the blades of a moving impeller causing noise and poor pumping ability
CCTV	Closed circuit television
CFC	Chlorofluorocarbon
CFD	Computational Fluid Dynamics
CIBSE	Chartered Institute of Building Services Engineers
Coaxial cable	Type of cable consisting of two concentric conductors separated by insulation, used to transmit high frequency (eg television) signals

TERM/ABBREVIATION	MEANING
Conductor	Set of wires, or conductors, which together form a power supply or data communication cable.
COBS	Control Office Base System
CP	British Standard Code of Practice
CPU	Central Processing Unit
dB	decibel
dB(A)	decibel related to sound level
DC	Direct Current
DIN	A German standard
DMRB	Design Manual for Roads and Bridges
DP	Double pole
Duct	Pipe or conduit for access to and mechanical protection of cables
Earth	Any zero-voltage point
Earth electrode	A conductor or group of conductors providing a sound electrical connection with the earth (soil or ground)
Earth leakage current	A stray current which flows to earth, in a circuit which is electrically sound
EDP	Emergency Distribution Panel
EHO	Environmental Health Office/Officer
EMS	Electronic Message Sign
EN	European Standard (or Euronorm)

TERM/ABBREVIATION	MEANING
EPROM	Erasable programmable read only memory
FOSD	Full Overtaking Sight Distance
Fuse	Protective device which operates and causes current flow to cease under overcurrent or fault current conditions
Glanded off	Cable fitted with a proprietary termination device or sleeve, employed to press packing tight on or around it, and the action of fitting such a device
GRP	Glass reinforced plastic
HGV	Heavy (or large) Goods Vehicle
HRC	High rupturing capacity
HTHW	High temperature hot water
HVAC	Heating, ventilating and air conditioning
High voltage (HV)	Voltage exceeding 1,000 volts AC or 1,500 volts DC between conductors, or 600 volts AC or 900 volts DC between conductors and earth
HSE	Health and Safety Executive
IBA	Independent Broadcasting Authorities
IEC	International Electrotechnical Committee
IEE	The Institution of Electrical Engineers
Impedance	A measure of the response of an electric circuit to an alternating current (resistance, inductance and capacitance)
Inductance	The property of an electrical circuit by which a voltage is generated by a change in the current

TERM/ABBREVIATION	MEANING
IP	Ingress Protection
I/O	Input /Output. The term is used to refer to those operations, devices and data-bearing media that are used to pass information into or out of a computer
ISMC	International Society for Measurement and Control (Formerly Instrument Society of America)
ISO	International Organisation for Standardization
kVAr	Kilovoltamperes Reactive
LCD	Liquid crystal display
LED	Light emitting diode
LSOH	Low smoke zero halogen
LTHW	Low temperature hot water
Low voltage (LV)	Voltage not exceeding 1,000 volts AC or 1,500 DC between conductors, or 600 volts AC or 900 volts DC between conductors and earth
LSF	Low smoke and fume
M&E	Mechanical and Electrical
MCB	Miniature circuit breaker
MCCB	Moulded case circuit breaker
MCC	Motor Control Centre
MCHW	Manual of Contract Documents for Highway Works
MICC	Mineral Insulated Copper Covered

TERM/ABBREVIATION	MEANING
MICS	Mineral Insulated Copper Sheathed
MIDAS	Motorway Incident Detection and Automatic Signalling
MIS	Management Information System
MTBF	Mean Time Before Failure
MTHW	Medium temperature hot water
MTTR	Mean Time to Repair
NMCS	National Motorway Communications Systems
OECD	Organisation for Economic and Cooperative Development
'On Snore'	The ability of a pump to run for a limited amount of time whilst cavitating
PIARC	World Roads Association PIARC (Permanent International Association of Road Congresses)
PID	Proportional integral derivative
PLC	Programmable Logic Controller/Programmable Controller
PSTN	Public switched telephone network
PVC	Polyvinyl Chloride
QWERTY	Standard UK keyboard arrangement

TERM/ABBREVIATION	MEANING
RCD	Residual current device (earth leakage circuit breaker)
RFAC	Royal Fine Art Commission
RF	Radio frequency
RFI	Radio frequency interference
RH	Relative Humidity
RMS	Root mean square value of voltage
ROM	Read only memory
RTD	Resistance Temperature Device
SCADA	Supervisory Control and Data Acquisition
Screen	To surround or encase a circuit with metal in order to reduce the effect of electric or magnetic fields
SELV	Safety extra low voltage system which is electrically separated from earth and from other systems in such a way that a single fault cannot give rise to the risk of electric shock
Short circuit	A deliberate or accidental low resistance connection, on an electrical circuit. (Its effect is to equalise voltages at two points and allow current to flow)
SP&N	Single pole and neutral
SSD	Sight Stopping Distance
SWA	Steel wired armoured. A cable type
Switchfuse	Fuse incorporating a switch or isolator, thereby enabling the power supply or devices fed from it, to be turned off

TERM/ABBREVIATION	MEANING
TAA	Technical Approval Authority
TDSCG	Tunnel Design and Safety Consultation Group
Telemetry	The measurement of events at a distance. Transducers are used to measure physical activities and to convert these to signals that reflect the measurement
TOA	Tunnel Operating Authority
TP	Triple pole
TP&N	Triple pole and neutral
Transit system	A system of intumescent compressible blocks within metal frames to seal cables and pipes where they pass through walls
Twisted pair	A cable consisting of a pair of conductors twisted around each other, in order to reduce interference
UPS	Uninterruptible power supply
VDU	Visual Display Unit
VMS	Variable message sign
XL	Cross linked
XLPE	Cross-linked Polyethylene

16. ENQUIRIES

Approval of this document for publication is given by the undersigned:

Quality Services Director
The Highways Agency
St Christopher House
Southwark Street
London
SE1 0TE

J KERMAN
Quality Services Director

Director, Road Network Management
and Maintenance Division
The Scottish Executive Development Department
Victoria Quay
Edinburgh
EH6 6QQ

N B MACKENZIE
Director, Road Network Management
and Maintenance Division

Director of Highways
The National Assembly for Wales
Cynulliad Cenedlaethol Cymru
Highways Directorate
Government Buildings
Cathays Park
Cardiff CF1 3NQ

K THOMAS
Director of Highways

Director of Engineering
Department of the Environment for
Northern Ireland
Roads Service Headquarters
Clarence Court
10-18 Adelaide Street
Belfast BT2 8GB

V CRAWFORD
Director of Engineering

All technical enquiries or comments on this document should be sent in writing as appropriate to the above.

APPENDIX A - SECONDARY CLADDING

General

A.1 Where the finish of the main tunnel structural support elements is not able to achieve sufficient smoothness for tunnel light reflectivity, easy cleaning and lack of dirt retention then a secondary cladding (wall lining) may be considered for achieving such objectives. Secondary cladding is also used to improve the appearance of a tunnel to the road user and to prevent any future water leakage from appearing on the road user side. Cladding has additional benefits in reducing drag losses for the tunnel ventilation system, insulation against freezing and reduction of tunnel noise. This Standard does not cover the use of eg epoxide paint systems for in-situ finishes to concrete or cast iron linings etc.

A.2 Secondary cladding surfaces are directly exposed to the tunnel environment and shall be designed accordingly, taking into account the tunnel size and shape, available space, tunnel use and the nature of any residual water ingress which it may be one of the functions of the cladding to intercept. See Chapter 2.

A.3 The needs of minimal maintenance with durability shall be designed into the secondary lining system. When maintenance or replacement of parts do become necessary, this shall be capable of being accomplished by non-skilled personnel, in time periods which minimise lane closure and traffic disruption.

A.4 Particular attention needs to be given to the design of details at panel joints and at the interfaces between panels and tunnel equipment, as these are the zones most vulnerable to the disfiguring effects of any seepages. Experience shows that seepage tends to be more able to circumvent a joint detail than unskilled design is able to prevent.

A.5 A generalised list of desired secondary cladding characteristics is as follows:

- i. Resistant to tunnel environment, without corrosion
- ii. Resistant to impact, abrasion, chipping by stones (particularly at lower levels), water, salt spray and cleaning chemicals
- iii. High light reflectance, diffuse not specular properties as described in Chapter 6

- iv. Non-combustibility, resistance to flame spread with non-production of noxious fumes, see Chapter 8 on Fire Safety Engineering
- v. Easily and quickly demountable and replaceable, in units
- vi. Resistant to applied traffic gust loading, fatigue and vibration, see Chapter 2
- vii. Economy of cost of installation, maintenance and replacement
- viii. Not attractive to dirt, over design life
- ix. Easily cleanable and resistant to loads applied by cleaning apparatus
- x. Neat, tidy, long term attractive appearance, without any quilting effect
- xi. Accommodates, and co-ordinates with, tunnel furniture
- xii. Ability to conform to shape imposed by tunnel alignment and cross section within space constraints
- xiii. Sound reduction and insulating properties, as required.

Materials

A.6 Several materials are commercially available for use as secondary tunnel cladding. These have been developed principally as cladding materials for buildings. A road tunnel environment is notoriously harsh and materials (or coatings) which appear to possess the correct properties, on the basis of laboratory tests, or long term performance as building cladding can exhibit particular weaknesses when exposed to such an environment, even for short periods. Different tunnels, because of differences in size, shape, internal layout or traffic composition and volume may expose such materials to environmental conditions of varying degrees of severity.

A.7 A panelling system will usually need a supporting framework of ribs or rails (the grounds) to impart stiffness and impose the required longitudinal and

transverse shape. The grounds together with the panels need to resist, without excessive deformation, the transient gust and suction loadings caused by the passage of traffic, and of withstanding, without widespread collapse, a vehicle impact load, which proximity to passing traffic may make likely. The grounds will be hidden and inaccessible for routine inspection and maintenance, and they may be exposed to seepages and the aggressive environment within a road tunnel. Therefore, confidence in the durability of the grounds, panels and their fixings, without continual maintenance, is required.

A.8 A surface finish of vitreous enamel, in the sense of its capacity to resist the harshest of tunnel environments, is generally acknowledged to be the best material. It is durable, impact resistant, not inflammable, easy to clean, and chemically inert but combination with a flat steel substrate leads to a product which may be relatively expensive in terms of initial cost. Paint coatings or forms of coated board possess lesser qualities but are less expensive in initial cost. The aim should be to match the properties of possible secondary cladding systems with the expected in-service conditions within each particular tunnel and compare the whole life costs.

Fire Properties of Secondary Cladding Materials

A.9 To distinguish between the various possible materials used for secondary cladding it is convenient to sub-divide materials into those which do, and those which do not, require a coating for corrosion protection and decorative purposes within a tunnel environment. The coating may affect fire propagation and its effects. See also Chapter 8.

A.10 Materials not requiring a coating but **suitable** for use in tunnels:

i. *Stainless Steel*

Stainless steel does not support combustion. See Chapter 2 for suitable grades.

ii. *Glass Reinforced Concrete (GRC)*

GRC is non-combustible and not easily ignitable. It tends to need thick sections and is easily stainable. It can be susceptible to failure from fatigue.

A.11 Materials not requiring a coating but **unsuitable** for use in tunnels are:

i. *Glass Reinforced Plastic (GRP)*

GRP can be formulated to possess a limited flame spread performance and smoke emission, but the production of acidic fumes during burning is unavoidable.

ii. *Polyvinyl Chloride (PVC) Sheets*

PVC does not support combustion, but when PVC based materials are burnt by continued exposure to a source of ignition the products of combustion include hydrogen chloride from the PVC and hydrogen cyanide from other constituents of the material. This is considered to be an unacceptable hazard which could also initiate the corrosion of metallic elements in the vicinity.

A.12 Materials requiring a coating are which **may be suitable** for use in tunnels:

i. *Aluminium Sheet*

Aluminium is generally considered to be non-combustible. However, in the rare event of successful ignition, it generates considerable heat. The protective coating proposed would be an important consideration in judging its potential fire hazard. Corrosion may quickly set in once the protective coating suffers local damage. It has a low resistance to impact damage.

ii. *Building Boards*

Cementations, fibre reinforced or wood particle boards coated on one side have been developed from uncoated versions and are used for insulation or fire resistance. They will burn when exposed to fire and so the manufacturer's Fire Test report issued by an accredited testing station shall be checked for the fire resistant property before the proposed board is considered for acceptance. Some boards are very brittle and easily shattered.

iii. *Mild Steel*

Mild Steel does not itself support combustion but, as with aluminum, its coating should be carefully chosen to avoid a potential fire hazard. A very high standard of corrosion protection is required. Corrosion may quickly set in once the protective coating suffers local damage.

iv. *Composite Cladding Panels*

Structures of metal composite panels using polymeric cores do not provide any standard of fire resistance. However a specific degree of fire resistance can be achieved by the use of suitable internal linings.

Design Life

A.13 Whatever materials are chosen for a secondary cladding system the minimum design life in service shall be 20 years. Inert and non-corrosive materials are capable of far longer design lives, subject to careful maintenance and not being damaged by vehicle impact. A design life for a particular system shall be specified which is a suitable multiple of 20 years, so that the secondary cladding systems may be renewed, as necessary, at the time which coincides with extensive tunnel equipment refurbishment.

APPENDIX B - DURABILITY AND MATERIALS

General

B.1 This Appendix gives further guidance on the materials and corrosion prevention finishes for tunnel equipment. Equipment must be protected against the hostile environmental conditions within tunnels to secure continuous operation, safeguards against structural failure, economy in maintenance and economic life span. See Chapter 2.

B.2 Extensive refurbishment has had to be undertaken in recent years because of water ingress through the tunnel structure. Watertightness should, therefore, be a prime design and construction requirement. See Chapter 2.

B.3 BS 5493 gives guidance on how to specify a chosen protective system. It also recommends specific methods of corrosion protection for steel structures in most environments. Preparation and application methods are also covered. The Specification for Highway Works, Series 1900 and Notes for Guidance shall be used to select an appropriate finish system for external tunnel works.

B.4 If there is any doubt as to the coating required, it is preferable to specify the operating conditions and obtain a binding guarantee from a specialist in protective systems.

B.5 Equally important as the specification of the coating system, is the monitoring of the quality of its application, from initial surface preparation to the final coat.

B.6 Some manufacturers, eg for electrical motors, provide a "standard manufacturer's finish". Any other type of coating may be prohibitively expensive and involve long delivery times. Where it is impractical to change the standard finish, the solution may be to overcoat on site with a compatible system giving the required performance.

B.7 Care shall be taken with rotating machinery, to ensure that bare steel shafts have suitable corrosion protection.

B.8 Consideration shall be given to the possibility of electrolytic corrosion. This can occur between fixings or joints of dissimilar materials and even between similar

materials eg some stainless steels where moisture is also present. To prevent electrolytic action in the tunnel environment, all equipment shall be bonded to prevent interaction, or equivalent special methods applied. Where cathodic protection is to be provided it shall be installed in accordance with BS Code of Practice 1021, or equivalent.

Design Life of Tunnel Equipment

B.9 Most equipment has an expected working life in the order of 20 to 25 years. See Appendix G. Therefore, the associated metallic components, plus their protection, shall achieve a similar life. For example, luminaires have an effective life of about 20 years and it follows that racking should last this length of time so that it may be replaced with the luminaires.

B.10 Jet fans may require shop maintenance after about 10 years, when they could also be repainted relatively easily.

B.11 Electronic equipment has an expected working life of 10 years. See Chapter 11 for electrical equipment.

Tunnel Environment

B.12 Products of combustion of hydrocarbon fuels (diesel smoke, benzenes, CO₂, CO, NO and water vapour) and road dirt which contains corrosive elements, road salt, road chippings and cleaning chemicals, together with a damp atmosphere, groundwater seepage, heat from engines and exhausts, and temperatures falling below dew point, combine to form a particularly aggressive environment for mechanical and electrical equipment. This may be further aggravated by chemicals and salts in the surrounding ground, groundwater and by a marine atmosphere in a coastal area. See also Chapter 2.

B.13 All equipment, plant, cables, materials and incorporated components shall be designed and installed to operate satisfactorily in such an environment for their design lives, with an ambient temperature range of -15°C to +35°C and relative humidity of up to 100%. Vibration effects due to traffic shall also be taken into account

Protective Measures

Cleaning

B.14 Regular cleaning is essential to good “housekeeping” of a tunnel and as an aid to encourage component maintenance. See Chapter 14.

B.15 Dust from the ventilation system and vehicle emissions will contribute to a build-up of dirt on the tunnel internal surfaces. Regular cleaning of the surfaces will remove this dirt and prevent corrosion from setting in. Dust left to build into thick layers can be a significant fire hazard.

B.16 Cleaning of the tunnel light fittings and the wall surfaces is important for the safety aspect of the operation. If dirt is allowed to build up on lighting the luminance deteriorates, as discussed in Chapter 6.

B.17 Normal cleaning procedure is to use a special tunnel cleaning machine to wash the tunnel with a strong detergent followed by some form of scrubbing action to remove adhered dirt and then a clean water rinse. It is important that the toxicity of the detergent is acceptable to the tunnel drainage system (see Chapter 7) and suitable protective equipment is provided for the cleaning personnel.

B.18 Dirt which accumulates in false ceilings or behind drip sheds or on high level crawlways may contain deleterious substances such as asbestos and concentrations of heavy metals. Adequate access for cleaners with protective clothing, extraction equipment and sealed rubbish containers may be necessary.

Design

B.19 Consideration shall be given to additional aspects of corrosion protection such as:

- i. The possibility of incorporating corrosion-resistant materials or coatings in the design, eg. plastics (non-toxic in a fire types, if used in significant quantities), carbon fibre, stainless steel, vitreous enamel etc
- ii. Possible damage to the coating system during transit and erection, and whether applied during fabrication
- iii. The maintainability of the coating system, as installed, without major dismantling

iv. The reliability of the system, ie its track record in similar environments

v. The possible effect of repair work on the coating

vi. The effect of fire on the coating, creating a possible smoke or toxic emission hazard dangerous to fire fighting personnel in sufficient quantities

vii. Elimination of water/dirt traps and crevices by careful design of components

viii. Provision of corrosion resistant fixings and supports and not just for the supported item.

B.20 Potentially aggressive ground water infiltration requires special consideration being given to construction materials suitable for such ground conditions eg the possibility of chloride and sulphate attack on concrete and reinforcement, eg methods of construction adopted for sub aqueous tunnels.

B.21 Finishes inside tunnels requiring the least maintenance are likely to last longest and provide better appearance. Attention paid to surface finishes from the early stages of tunnel design invariably proves cost effective in the long run, since labour costs for maintenance continue to rise.

B.22 All surfaces require cleaning, which is a relatively unskilled process. Paintwork will require preparation work and re-coating at certain intervals and requires skilled manpower. It is disruptive and time consuming.

B.23 Care shall be taken in the design of equipment installations to allow sufficient access for maintenance of tunnel surfaces.

Mechanical Protection

B.24 Protection, in the form of a surface coating, can be achieved either by paint, plating, metal spray or a combination of these. Surface coatings for steel are numerous and the initial cost must be considered together with the frequency and extent of subsequent maintenance requirements.

Examples of Tunnel Materials and Finishes

Item	Material & Finish
Emergency Point Cabinets (see Chapters 8, 11)	Stainless steel or vitreous enamel
Electrical switchboards (see Chapter 11)	Painted steel
Crash barriers	Galvanised steel
Handrails	Galvanised and painted steel, stainless steel or vitreous enamel
Secondary cladding precast segment lined tunnels or cladding of diaphragm walls	Coated aluminium, or vitreous enamelled steel sheeting on aluminium or stainless steel framing
Fire hydrants, hose reels and other fire fighting equipment	Steel or ductile iron pipework, gunmetal or brass fittings
Fans	Generally painted steel bodies, aluminium or steel rotors, specified electric motors, stainless steel accessories
Luminaires	Epoxy powder coated aluminium alloy bodies, stainless steel accessories
Racking, hangers, cable trunking, conduits and fixings.	Galvanised steel or stainless steel

equipment such as switchgear, controls and monitoring systems is overtaken by advancing technology. Fire precautions also develop with time requiring, for example, improved ventilation systems to give better smoke control and the replacement of PVC insulated cable with LSOH insulated.

Tunnel Refurbishments

B.25 Tunnel refurbishment may need to be considered when the tunnel design has become outdated, or the tunnel structure and finishes require remedial work. There may be no alternative to major refurbishment if a system requires updating, but early remedial work to avoid corrosion problems will prolong the life of the structure and its equipment.

B.26 It is mainly the M&E services and secondary lining systems of a tunnel that will be subject to refurbishment, as there is usually little that can, or needs to be done, to refurbish a tunnel structure. Much tunnel

APPENDIX C - TUNNEL DOCUMENTATION: TYPICAL CONTENTS

General

C.1 Requirements for tunnel documentation are discussed in Chapter 13. This Appendix lists typical contents of such documentation for guidance purposes only. It is not necessarily exhaustive.

Tunnel Commissioning Documentation

C.2 Specific documents should be provided on completion of the commissioning of tunnel equipment for record, handover and warranty purposes, including:

History Records

These would be in the form of relevant letters relating to specific equipment, agreements and minutes of meetings. A systematic numbering system is required.

Alert Notices and Field Service Reports

A historical record comprising the list of faults noted during inspection and actions taken, adjustments and modifications either completed or to be carried out.

Works Test Certificates

These would cover rotational and electrical continuity and enclosure checks in case of electric motors, switch gear, panel assemblies, annunciator alarm system, etc.

In the case of fans, pumps etc volumetric test reports would be required.

Photometric, insulation and enclosure test certificates would be required for lighting units for both prototypes and production units.

Site Test Certificates

All equipment and systems will be tested to verify their performance after installation on site. Test results will be documented, signed and countersigned for record purposes.

Test certificates would normally be required for individual equipments such as:

- i. Ventilation fans
- ii. Drainage pumps
- iii. Switch gear
- iv. Diesel generator sets.

Performance test certificates should also be provided for the following systems:

- i. Ventilation control system
- ii. Drainage control system
- iii. Lighting
- iv. Fire detection and extinguishing system
- v. Traffic surveillance system
- vi. Electrical cable system
- vii. Communication system
- viii. Computer control and data logging system.

Where more than one piece of equipment of a given type is installed test certificates should be provided for each unit.

Statutory Documentation

This will include insurance inspection certificates for

- i. Lifting equipment
- ii. Pressure vessels such as compressor air receiver
- iii. Boiler plant, if relevant.

Tunnel Operator's Guide

C.3 The Tunnel Operators Guide should meet the requirements of Chapters 13 and 14. It should refer to manufacturers' operation and maintenance manuals for detailed instructions on equipment. The document should contain some or all of the following information:

General

- i. Glossary of terms
- ii. Schedule of drawings
- iii. Useful telephone numbers
- iv. Tunnel design and operation philosophy
- v. Equipment automatic controls.

Operating Procedures

- i. Traffic control procedures
- ii. Traffic plan
- iii. Description of control console, operators keyboard, VDU and printer facilities, together with details of any manual and police controls
- iv. Security systems
- v. Safety procedures
- vi. Emergency facilities
- vii. Emergency procedures.

Control System

- i. Data acquisition and monitoring
- ii. Control and command facilities and terminal location
- iii. Air quality and visibility monitoring
- iv. Control room equipment
- v. Data of outstation location and equipment
- vi. Tables of VDU and printer out-turn, commands, Police messages, codes.

Electrical and Mechanical Safety Regulations

These should be stated in detail together with the procedure for authority to work on electrical or mechanical plant.

Schedule of Equipment

- i. All mechanical and electrical equipment installed
- ii. Drawings with respect to identifying operating locations.

Electrical Supplies, Standby Supplies, Earthing Systems

- i. High voltage distribution system
- ii. Low voltage distribution system
- iii. Transformers
- iv. Inverters and batteries, where provided
- v. Remote alarms and indications
- vi. Earthing systems
- vii. See also *Standby Electrical Supplies* item.

Tunnel Lighting

- i. Description of the lighting system
- ii. Description of the lighting system controls, auto and manual
- iii. Description of the lighting distribution system
- iv. Description of the lighting transfer, auto to manual
- v. Description of the lighting for any contra flow working
- vi. Description of the emergency lighting system
- vii. Description of other details specific to the tunnel lighting design
- viii. Details of remote indication and alarms
- ix. Tables of luminaire arrangement, settings and electrical load.

Tunnel Ventilation

- i. General description of the ventilation system
- ii. Ventilation electrical distribution system
- iii. Ventilation control system - auto
- iv. Ventilation control system - manual - with control either via keyboard or hand switch
- v. Tables giving CO, NO_x and visibility operational levels
- vi. Tables giving fan group setting, change over procedure.

Pumping, Valves, Gas Sensors

- i. Pumps and pumping stations
- ii. Pumping duty and changeover sequence
- iii. Gas sensors and emergency sump entry requirements.

Standby Electrical Supplies

- i. Uninterruptible Power Supplies (UPS)
- ii. Standby Emergency Diesel Generation
- iii. Changeover switching procedure.

Fire Alarm, Fire Mains and Other Fire Extinguishing Systems

- i. Fire alarm and extinguisher system including tunnel service buildings
- ii. Portable extinguisher equipment
- iii. Hose reels
- iv. Fire pump system where installed
- v. Fire mains and relevant isolating valves
- vi. Fire zones.

Tunnel Structure and Secondary Linings

- i. Ground water control
- ii. Stability of slopes, particularly over portal areas
- iii. Convergence monitoring
- iv. Wall painting
- v. Wall cleaning
- vi. Cladding cleaning, removal and replacement for inspection
- vii. Waterproofing
- viii. Pavement surfacings, markings
- ix. Anchorage monitoring, equipment supports
- x. Long term settlement monitoring
- xi. Fire protection.

Building Services and Security

- i. Heating and ventilation system
- ii. Water and drainage
- iii. Lighting and power
- iv. Alarm system.

Traffic Signs and Signals

- i. Equipment details
- ii. Operation procedures.

Communications

- i. Service telephones
- ii. Emergency telephones
- iii. Radio system and block diagram.

Schedule of Drawings

- i. Local area map
- ii. Road layouts
- iii. Traffic flow layouts
- iv. Main services and buildings
- v. Zones of control where applicable
- vi. Radio net
- vii. Equipment drawings.

Equipment Operation and Maintenance Manual

C.4 The Equipment Operation and Maintenance Manual should meet the requirements of Chapter 13. It shall contain all necessary information in a form suitable for a proprietary computerised maintenance system:

- i. General description of each item of plant and equipment and asset register. For each asset (eg iii. to xiv.) the following information is required:
 - a. Location within tunnel site
 - b. Details of manufacture including contact information

- c. Technical specification: including functional hierarchies, state variables and safety tolerance boundaries, rule based preventative maintenance requirements and help files
 - d. Parts, specialist tools list
 - e. Maintenance schedule, in a diary form suitable to show work due, work completed (with automatic entry into item e.) and work overdue including status queries on selected fields
 - f. Maintenance and operational history facility including in-service duty hours recording.
 - ii. Relevant design information, including summaries of design calculations, performance data and equipment general specifications.
 - iii. Cable, circuit and equipment schedules, general arrangement and schematic drawings.
 - iv. Control system:
 - a. Main equipment
 - b. Traffic surveillance and control
 - v. Tunnel ventilation
 - vi. Tunnel lighting
 - vii. Emergency telephones
 - viii. Operator telephones
 - ix. Radio Service Buildings
 - x. Emergency/Distribution Panels (EDPs)
 - xi. Smoke control panels
 - xii. Gantry structures
 - xiii. Tunnel carriageway drainage and outfall
 - xiv. Pumps, pipework and valves
- i. All equipment and carriageways should be inspected daily and any abnormal operating condition reported.
 - ii. Daily performance of equipment should be recorded, from visual checks on instrumentation readings which show values outside those to be expected, and from direct viewing of the carriageway and of lighting performance and condition of emergency services facilities. The data should be reviewed and all fault indications reported.
 - iii. Routine equipment inspections should be made at such intervals as are recommended by the various suppliers, when the equipment should be inspected in detail. The equipment operation should be checked against the design standard for both automatic and manual control.
 - iv. Alarms should be checked with response of equipment to variations in priorities and in the set point and range settings of alarm parameters.
 - v. The performance of automatic control equipment should be monitored against variations in the controlled parameters.
 - vi. Records should be made of vibration and noise levels of relevant equipment.
 - vii. The response of all Emergency Services should be checked and their combined response to simulated incidents should be regularly monitored, together with that of staff.
 - viii. All recorded data should be reviewed and recommendations for actions should be reported against long term trends, hard copies being retained to record such trends.
 - ix. When major equipment maintenance is necessary, records should be made of equipment condition to supplement the computerised data for equipment performance.

Manual for Police and Fire Services

C.6 The Manual for Police and Fire Services will typically contain a set of guidance, as follows:

Location and Access

Tunnel location with access provision for emergency and maintenance services should be shown on a map and/or diagram.

Inspection Check List

C.5 An inspection check list will typically contain a set of instructions as follows:

Structures

The tunnel and associated buildings should be briefly described and illustrated by detailed diagrams and sketches. The location and layout of emergency services and details of equipment should be included and illustrated. Any items which are unusual or special to the particular tunnel should be emphasised.

Electricity Supplies

The source of electricity supplies should be stated together with means of providing any uninterruptible and standby supplies, with limitations and arrangements for emergency operation.

Security

All automatic controls and alarms should be listed with operational consequences and action required by the police or fire services.

Communications

The various communications systems provided in the tunnel complex should be fully described together with procedures particular to the tunnel and any test procedure actions required. A telephone directory for any internal telephone system should be provided together with BT (British Telecom) telephone numbers and brief details of provision made for operation of radio systems in the tunnel

Drainage and Pumping, Fire Hoses

All drainage systems, sumps and pumping equipment should be briefly described and sumps and pumps located, together with action required in the event of an alarm and any other police/fire action envisaged. Provision for control of the spillage of hazardous liquids should be covered in detail and operational responsibilities defined. The location and any special operating conditions for permanent fire hoses should be fully defined.

Lighting

The automatic main and emergency lighting arrangements should be described together with any police procedure for provision of standby power supplies. Any provision for police manual control should be detailed together with any limitations and a description of any additional control available to the maintenance staff.

Ventilation

The ventilation plant normal operating arrangement should be described and any automatic control actions defined. Any provision for police/fire service manual control should be detailed, including any reason for, and effect of, manual controls, any limitations, and a description of any additional controls available to the maintenance staff. Any police/fire action necessary in response to fault alarms should be detailed.

Plant Monitoring

A description should be given of all automatic control system (computer) originated messages, together with the required response, similarly for printer messages (where a printer is installed) and alarm signals. It is important that all information provided is free of ambiguity particularly where interpretation may be by non technical personnel working under stress induced by any emergency. All prescribed alarm messages should be listed, together with the police/fire response required.

Traffic Surveillance

A description should be given of any traffic surveillance system.

Abnormal Situations

The expected alarm response to any system failure should be stated and the required response defined. The possible consequences of any failure to act should also be stated.

APPENDIX D - GUIDELINES FOR MAJOR INCIDENTS OPERATIONS AND FIRE TESTS

General

D.1 The basic operating procedures and supporting documentation for dealing with major incidents in tunnels is set out in Chapters 8, 13, 14 and Appendix C. This Appendix adds some guidance for emergency major incident operations, particularly in relation to planning a suitable response to fire.

D.2 Major incidents, whether or not involving fire, have common features in that immediate response is needed to facilitate rapid access of the emergency services to the site of the incident, evacuation of casualties and restoration of traffic flow as soon as practical.

Initial Response and Traffic Control

D.3 The quality of the decisions and resulting response made in the first ten minutes after an incident occurs is vital. The initial response, on detection of a major incident, shall be to stop all traffic entering the tunnel in **both** directions, followed immediately by summoning the emergency services appropriate to the incident. Traffic downstream of the incident and in any unaffected bores shall be allowed to proceed out of the tunnel, leaving clear access for emergency services. The initial alarm will trigger the initial response. During the initial response time (which should be known fairly accurately for given conditions) the tunnel control centre will pass as much information (nature, seriousness, size, traffic, casualties, evacuation progress, best direction of approach etc) to the emergency services so that the most effective deployment can be made onward from arrival at the rendezvous points. An Initial Response and Traffic Control Plan will have been already prepared by the TDSCG. This shall include for:

- i. Normal approach routes
- ii. Alternative approach routes to be used if normal approach routes are congested
- iii. Agreed rendezvous points, as near as possible to the tunnel portals
- iv. Agreed initial mobilisation levels/resources.

D.4 Occupants may be reluctant to leave their vehicles unless a uniformed member of the police or emergency services is directing them. Any tunnel staff at the scene early in the incident should use their best endeavours to communicate directions to the public, before handing over on arrival of the emergency services.

D.5 Once the unaffected bore is clear of traffic, then any necessary action can be taken, for example, by illuminating escape route signs, to evacuate vehicle occupants through the cross passages into the adjacent bore.

D.6 In the event of fire in a single-bore two way tunnel, vehicle occupants shall first be evacuated from the side of the fire to be used for smoke clearance and before operating the smoke control fans. Reversible fans shall be first checked to ensure that they are set to operate in the intended smoke clearance direction.

D.7 Shorter, naturally ventilated tunnels, without mechanical ventilation, allow vehicle occupants to escape quickly via the short distances to reach the tunnel portals and cross passages. Emergency services should be aware of possible smoke direction reversals, as wind directions change, or chimney effects for tunnels built on a gradient.

Smoke Control (in the event of a fire)

D.8 If an incident involves fire, the ventilation fans should be stopped and switched to manual control. As soon as traffic has ceased moving in the tunnel an assessment should be made of the location of the fire and the fans switched to the operating mode best suited to the particular conditions. For example, in a one-way bore with longitudinal ventilation, once traffic has cleared and the CCTV shows that there are no people downstream of the fire, the fans can be switched on to push the smoke and hot gases in that direction. Smaller fires may not generate sufficient heat for stratification of smoke layers in the tunnel ceiling to occur. For such cases, lower level smoke logging will occur and fan speeds shall be adjusted to levels sufficient to clear the smoke logging. Changes to fan operation shall only be made with the agreement of the fire officer in charge.

D.9 In a two-way tunnel smoke control is more difficult, as traffic will probably be backed up both sides of a fire. In still air, the heat and products of combustion will rise and spread along the ceiling of the tunnel. Any application of forced ventilation in a longitudinal system will increase the rate of spreading in one direction (and reduce it in the other). So, the fans should remain switched off until it is verified that no persons remain downstream of the intended direction of smoke clearance. It will normally be quickest to clear the vehicle occupants in the lanes where the distance from the incident position to the nearest portal is the shortest.

D.10 Where a fully transverse ventilation system is installed the fans should be switched to full extract as soon as a fire is detected. For semi transverse and combination systems, the above principles for the longitudinal flow component apply.

D.11 The emergency operating procedures for smoke control shall be drafted taking into account the above, the results of at least one full scale emergency drill and preferably the results of a practical fire test.

Additional Actions to be Taken During and Following a Major Incident

D.12 In addition to the basic actions set out in Chapter 14, additional actions listed in this section may be necessary. Their need and order of priority will depend on the type of incident and whether or not there is fire.

During the Incident

- i. Ensure investigating personnel proceed into the tunnel in the direction of the traffic flow or smoke clearance direction (two way tunnels) and not into the path of dense smoke.
- ii. Ensure that no persons proceed into the tunnel without first receiving confirmed information, via the Traffic Control Centre, regarding traffic and smoke.
- iii. Establish a Control Point Area and keep the area clear except for personnel involved in operations for the incident.
- iv. Sound klaxon, where provided, in the Control Point Area. A klaxon is effective in alerting road users that the emergency is real eg installation at Clyde Tunnel.

- v. Instruct the Portal Control Points staff to maintain a “clearway” including cross over lanes for possible contra flow of emergency vehicles.
- vi. The Traffic Controller will monitor the incident on CCTV and assess the nature and seriousness of the incident, taking further action as appropriate.
- vii. Arrange for any necessary additional uniformed and maintenance staff to report for duty.
- viii. Advise relevant managements and the media.
- ix. Arrange additional canteen facilities to be available for the duration of the emergency.
- x. The Traffic Controller should instruct staff to assist in the evacuation of persons in the tunnel.
- xi. Advise staff to ensure that ignition keys are left in the ignition switches of abandoned vehicles, their doors closed but left unlocked.
- xii. If appropriate and system available, broadcast “evacuate tunnel” message.
- xiii. Depending on the nature and the scale of the incident the following facilities may be required by the emergency services:
 - a. Casualty collection point
 - b. Evacuation assembly point
 - c. Mortuary collection point.
- xiv. Maintain liaison with emergency services to assist in dealing with any injured persons.
- xv. NB: a major incident may overload communication channels with enquiries. It is advisable to have a separate public enquiry telephone system set up and staffed by a suitably trained person/s. Automatic switchboards should be set to manual and lines reserved for outgoing calls.
- xvi. It is important to know at all stages the locations of all staff.
- xvii. The availability of keys for normally locked doors and gates requires regular monitoring. Combination locks or keypad systems can be effective. Codes may be radioed/phoned to staff, as necessary, and codes regularly changed for security reasons.

After the Incident is Over

- i. Broadcast, by radio, an internal fire alarm clear code to Traffic Officers. Guide drivers and passengers to abandoned cars at the scene of the incident.
- ii. Establish tidal-flow in unaffected lane or contra-flow in the unaffected tunnel bore, as appropriate.
- iii. Allow in the pre-arranged emergency call out contractors to undertake their works such as vehicle removal, vital equipment replacement, pumping and sludge removal etc.
- iv. As and when circumstances permit, progressively return to normal traffic flow.
- v. Enter details in Control Point Log.
- vi. Prepare and submit a full report.

Fire Tests

D.13 It is recommended that for tunnels with mechanical ventilation, full scale fire tests are carried out, prior to opening a tunnel, to verify the emergency procedures, including fire detection and alarm, traffic control, emergency services response time and the smoke control system.

D.14 This section discusses the tests to verify smoke control procedures.

Test Method

D.15 Tests should be conducted using the draft emergency operating procedure for the tunnel, which will include appointing a person with overall responsibility for coordination.

D.16 Firemen should be prepared to control the fire using the equipment available at the tunnel emergency points. A fire appliance should also be in attendance in case of any failure of the tunnel equipment or procedures.

D.17 Instrumentation should include air velocity and direction measurement, temperature measurement at 5m, 10m, 20m, 50m, and 100m from the fire in both directions at the road level, at 1.5m above the road and at the level of lighting cables or other vulnerable equipment in the top 3m of the tunnel cross-section. Ambient temperature and air velocity should be

measured before and after the test. Temperature data and the output from the tunnel's normal CO, smoke and air velocity measuring equipment should be continuously recorded during the test. Photographic, video or other recording of the smoke development should be made.

Heat and Smoke Sources

D.18 Cold smoke generators are not suitable sources, as the smoke does not have the correct buoyancy. A suitable fire can be produced by burning a mixture of 25 litres of petrol, 5 litres of gas oil and pieces of car tyre, in a 4m³ steel tank placed above a heat insulated and protected road surface, burning a steel fire tray of oil within a large skip insulated from the road, or by burning an old car. Experience shows that fires of this size are unlikely to damage the tunnel if carefully sited in relation to vulnerable equipment. Hot smoke generators are currently under investigation.

Useful Precautions

D.19 To protect the carriageway the fire should be placed on corrugated iron sheets or a 20cm thick bed of sand or on blocks, with the carriageway watered during the test.

D.20 The test should be carried out before the tunnel ceiling or vault is painted or any acoustic treatment applied. Fire experience suggests that the test fires recommended above will not damage the ceiling etc, provided the ventilation is operated. However, a larger fire, equivalent to an HGV, could be expected to damage the ceiling etc. Side-wall equipment is not likely to be affected, but plaster plates covering the sidewalls for a length of 8m, the lighting for 10m and cables for 20m could be used as a precaution. Use of an insulating fire blanket, attached to the adjacent tunnel walls and ceiling above will also ensure protection of any finishes.

D.21 If an old car is used the petrol tank must be emptied of petrol and filled with water to prevent explosion, any tyres shall have their valves removed prior to burning. The burnt car shell must be handled carefully after use and some components can become toxic after exposure to fire

Test Report

D.22 The test report should record the attending personnel, the objectives, conditions and method of the tests, the initial condition, instrumentation, description of the development of the fire including the smoke movement, measured data and analysis, evaluation of the fire intensity and lessons to be drawn and acted upon.

APPENDIX E - RECENT RESEARCH BY THE HIGHWAYS AGENCY

General

E.1 The Highways Agency of the Department of Environment, Transport and Regions (formerly the separate Departments of Environment and Transport) has undertaken a comprehensive programme of research work in road tunnel subjects. A summary is provided of the more recent, but as yet unpublished, reports and papers relevant to the planning, design and equipping of road tunnels.

E.2 Unless specifically referred to within the Chapters of this Standard such reference documents are intended for information and guidance only and may not be taken to reflect the current policy of the Overseeing

Organisations. Documents will from time to time be updated or superseded and designers shall ensure that they are working to the most current versions. See also Chapter 15.

E.3 Development work on New Austrian Tunnelling Method (NATM), the Observational Method in Tunnels, Limited Facility Tunnels, Road Tunnel Maintenance and Civils Specifications for the Construction and Maintenance of Road Tunnels will be published in Departmental Standards and Specifications currently under development.

E.4 Copies of reports may only be obtained with the prior approval of the Highways Agency.

PROJECT REPORTS

E.5 The following unpublished reports may exist only in draft form:

Report No.	Title	Summary
PR/CE/42/94	Computer Models To Determine The Distributions And Effects Of Tunnelling Induced Ground Movements. R Andrews	The study is in two parts, namely the prediction of ground movements arising from tunnelling activities in soft ground and the prediction of damage to structures due to ground movements. It describes the mathematical basis of calculation methods and illustrates the capabilities of computer software to perform calculations in each of these areas.
PR/CE/66/94	Construction Impacts At the Pen-Y-Clip Tunnel. D M Hiller	The report considers the effects of construction works at the Pen-y-Clip tunnel and provides a case study against which future schemes may be appraised and any objections may be judged.
PR/CE/128/95	The Application of a Service Tunnel in the Design of Highway Tunnels in the UK. R J F Goodfellow, P J Astle and D M Hiller	The report investigates the application of separate service tunnels in the design of highway tunnels. It seeks to highlight the benefits to the planning, construction and long term maintenance of the tunnel and to demonstrate the conditions where the benefits outweigh any additional construction costs.
PR/CE/163/95	Review of Single Pass Tunnel Linings For United Kingdom Highway Tunnels. P N Groves and T W Mellors	The report contains a review of single pass tunnel lining techniques, based on case histories of construction projects worldwide, in relation to their applicability to highway tunnels in the United Kingdom. It starts with a review of tunnel construction practice, in terms of primary and secondary linings, leading to a review of single pass lining methods.

Report No.	Title	Summary
PR/CE/164/95 PR/CE/195/96	The Prediction of Ground Movements Caused By Tunnelling. B M New	The reports review and provide guidance on the prediction of ground movements caused by tunnelling works. The guidance is applicable to the predicting the potential impacts of tunnelling schemes and to the assessment of the effects.
PR/CE/169/95	Design Criteria and Concrete Mix Requirements for Below Ground Construction A J Powderham, J Forbes, H B Shanghavi and N R Buenfeld	The report reviews the current design recommendations and concrete mix requirements for structures constructed below ground and in particular criteria for controlling early age thermal cracks. The review highlights the importance of empiricism, describes ambiguities in current design criteria, and gives cost comparisons for changes in design criteria.
PR/CE/12/96	Design Fire Loading For Major Highway and Limited Facility Tunnels R D Andrews	A report on the fire rating and duration times that could be used for road tunnel design including limited facility tunnels which admit only cars and vans.
PR/CE/37/96	Ground Classification Systems in Tunnel Construction G I Crabb	A review of the current methods of classification of the ground for tunnel support and an approach to ground classification which will assist in setting up cost effective contracts for new tunnelling works.
PR/CE/110/96	A Review Of The New Austrian Tunnelling Method. K Bowers	The report reviews issues arising from the recent experiences of NATM in the UK and gives guidance on the potential future application of the system.
PR/CE/144/96	The Potential Application of Risk Analysis to Highway Tunnel Construction. J J Conway, R J F Goodfellow, D M Hiller and K H Bowers	The report reviews the range of current risk assessment practices in the UK with special reference to how they may be applied to road tunnel schemes. The nature of risk is discussed with particular attention to those risk factors which may heavily influence the success of such projects.
PR/CE/151/96	CFD Modelling of Fires In The Memorial Tunnel. S D Miles and S Kumar (BRE)	The report describes the application of the CFD fire model TUNFIRE to the task of modelling a series of fire tests performed within the Memorial Tunnel, USA.
PR/CE/152/96	Assessment of HSE Tunnel Fire Tests. R D Andrews	The report briefly describes tests representing a truck fire occurring on board a heavy goods vehicle shuttle train in the Channel Tunnel. The main aim was to investigate the manner in which forced ventilation could control combustion products and ensure a safe environment for truck drivers travelling in the amenity rail coaches. A further objective was to provide experimental data to compare with computational fluid dynamics (CFD) predictions.
PR/CE/153/96	Environmental Considerations For Highway Tunnels - Status Report. J Cloke and R D Andrews	The report seeks to define and identify the relevant environmental impacts associated with the construction and operation of road tunnels.

Report No.	Title	Summary
PR/CE/174/96	A Review of Lining Design Practice for Bored Highway Tunnels. N A Moss	The report provides an overview of the tunnel design process, outlining the approaches currently adopted to tunnel lining design. The report presents the elements required for the design of a tunnel lining, focusing on the analytical and numerical analysis of the ground structure interaction problem.
PR/CE/203/96	The Prediction and Mitigation of Tunnelling Induced Ground Movement Damage to Structures. D M Hiller, K H Bowers, J D Redgers, J M Reid and G Clark	Building on previous work, this report concentrates on relating the predicted ground movements to the nature and magnitude of their likely adverse impacts on overlying structures. Additionally means of mitigating the adverse effects of tunnelling induced ground movement have also been investigated.
PR/CE/50/97	Prospects For Single-Pass Sprayed Concrete Linings in Highway Tunnels. G I Crabb	The development of sprayed concrete linings for highway tunnels offers the potential for considerable construction cost savings by eliminating the need for a waterproof membrane or a cast concrete final lining. However, there are considerable reservations over such aspects as the watertightness, durability and surface finish achievable. The report addresses such concerns.
PR/CE/56/97	Environmental Considerations For Highway Tunnels. R D Andrews and J Cloke	The report includes discussions on air quality, noise, vibration, geology and soils, ground movements, hydrogeology and drainage, ecology, landscape, archaeology and the built heritage, severance, underwater tunnels, driver perceptions and anti-road protest action. Appropriate assessment methodologies are outlined and, where available, methods for mitigating the major disbenefits are proposed.
PR/CE/109/97	A Review of Factors Influencing the Design and Construction of Highway Tunnels. D M Hiller & J D Redgers	Four particular areas of tunnel design and construction are considered to update and expand information previously presented, namely: Environmental effects of the construction works, the application of service tunnels to highway tunnels, ground classification methods and application of risk analysis techniques to highway tunnels.
PR/CE/148/97	Review of Tunnel Lighting Levels in BS 5489. S Bird	The lighting levels required by BS 5489:Pt.7 have been questioned as to being too high and inappropriate for the traffic speeds actually achieved. An interim report reviews tunnel lighting levels and identifies areas where economies might be possible.
PR/CE/159/97	Value Engineering of Tunnel Equipment. J Potter	An interim report reviews the methods available for applying value engineering to tunnel equipment, using data from the A55 North Wales tunnels. The report introduces the subject of value engineering for road tunnels and proposes the development of a whole life costing model.

Report No.	Title	Summary
PR/CE/183/97	Limited Facility Tunnels and Bridges. K Bowers, D Hiller & R Evans	The report brings together advice on design, operation and maintenance of limited facility underpasses, sought from a number of agencies, and provides a commentary on the content, adequacy and suggested amendments to HA Standard TD 43/95 (draft), together with a revised draft of the Standard.
PR/CE/195/97	Highway Tunnel Ventilation - Status Report. Dr Robin Andrews	The report describes the purpose of tunnel ventilation, available types of ventilation and control mechanisms and their performance. Areas of tunnels design improvement which could lead to more efficient ventilation performance are outlined and maintenance issues briefly discussed. Results of field experiments on portable emergency ventilation equipment are presented.
PR/CE/201/97	Specification, Notes for Guidance & Method of Measurement for Highway Tunnel Construction and Maintenance (Phases 1 and 2). S Bird	The document consists of a review and appropriate development of the British Tunnelling Society Model Specification for Tunnelling. Areas for further study in Phase 3 are to be identified.
PR/CE/31/98	Maintenance of Highway Tunnels. S Bird	The report reviews factors to determine the necessary scope of a draft Advice Note on the Maintenance of Road Tunnels: namely the scope of advice necessary; the connection between maintenance and design, equipping and operation; and requirements of users of the advice.
PR/CE/57/98	Review of Forms in BD53 S Bird	A review of the content and adequacy of the forms contained in BD53 (DMRB 3.1.6) and proposals for changes to permit its use with a computerised recording system.
PR/CE/73/98	The Prediction of Tunnelling Induced Ground Movement: Prediction and Consequences. K Bowers	The report presents an approach to the prediction of ground movement arising from a range of tunnelling activities in various ground conditions. Guidance is given on the choice of appropriate analysis and parameters for commonly encountered situations.
PR/CE/80/98	Value Management and Engineering Workshop. G Clarke	Records a Value Management and Engineering workshop arranged to re-examine the present level of provision of equipment provided in highway tunnels, to seek areas where economies could be made without compromising safety or increasing congestion.
PR/CE/143/98	Single Pass Tunnel Linings Final Report. R H Dimmock	The report focuses on the problems and subsequent development of sprayed concrete technology. It describes the current state of the art in its technology and associated material performance characteristics achieved using the wet mix application process. The report also assesses the benefit of steel and polypropylene fibre reinforcement.

APPENDIX F - TUNNEL DESIGN AND SAFETY CONSULTATION GROUP (TDSCG) REQUIREMENTS

General

F.1 The Tunnel Design and Safety Consultation Group (TDSCG) is required to discuss and agree road tunnel design and refurbishment proposals affecting operational requirements in the context of the topics listed below, where applicable to the tunnel under consideration. See Chapter 1. The list shall be regarded as the minimum requirement and is not intended to be exhaustive. Individual tunnels or groups of tunnels may have certain additional features which have a direct bearing on operational safety. Such features shall be added to the list.

Topic List

F.2 The minimum list of topics for discussion and agreement by the TDSCG are presented in the order of the relevant Chapters, as follows:

Chapters 2 and 14

- i. Safety and operational effectiveness of the overall system proposed for the tunnel
- ii. Identification of emergency incident and hazard scenarios to be effectively dealt with
- iii. Requirements for the passage of hazardous goods
- iv. Contribution of TDSCG Report to Road Safety Audit
- v. Personal safety equipment provision, training needs.

Chapter 3

- i. Any unusual features of the tunnel which may give rise to particular hazards
- ii. The level of provision of emergency points, stopping lanes, walkways and refuges and escape routes for emergency use
- iii. The level of provision of communications and fire fighting equipment.

Chapter 4

- i. The siting of signs and gantries
- ii. The general layout in terms of standby areas at portals, vehicle recovery and cross-over and contraflow arrangements for emergency and maintenance purposes
- iii. Access for Police and Emergency Services
- iv. Considerations for tunnel users making use of emergency points/escape facilities.

Chapter 5

- i. The adequacy of the ventilation system (where provided) to maintain an acceptable air quality during all normal operation and tunnel maintenance scenarios
- ii. Any restrictions that may need to be imposed on traffic or maintenance operations due to limitations of the ventilation system
- iii. The performance and operation of the ventilation system in all foreseeable fire or emergency situations, including plans for automatic and manual ventilation control.

Chapter 6

- i. Cleaning and maintenance regimes and related tunnel closures and traffic orders
- ii. Exit lighting design in terms of traffic management for special and emergency operating conditions
- iii. Security of supply, use of UPS and need for stand by generators.

Chapter 7

- i. The operational assumptions of the inflow rates upon which the design of the drainage system is based
- ii. The possible results and hazards of abnormal storm conditions exceeding the design criteria.

- iii. The ability of the drainage system to accept and safely contain a hazardous spillage
- iv. The acceptability of arrangements to discharge storm water and polluted water (eg from tunnel cleaning operations or spillages)
- v. The proposed means of disposing of hazardous or other substances which cannot be discharged normally
- vi. Arrangements and procedures for inspecting and cleaning pipework and sumps, including procedures for any confined spaces.
- iv. The requirements and provision of equipment for the radio rebroadcast facilities of the emergency services
- v. Provisions for removing broken down vehicles etc from within the tunnel.

Chapter 8

- i. The initial response by the Police, Emergency Services and Tunnel Operating Authority of the Maintaining Agent, in terms of the facilities deployed in accordance with this Chapter. Consider advice contained in Home Office Technical Bulletin 1/1993: Operational Incidents in Tunnels and Underground Structures: HMSO.
- ii. Coordination of operating procedures and contingency plans of the Police and Emergency Services attending an emergency. Consideration of partial or full loss of any facilities due to fire damage or explosion.
- iii. The satisfactory review and necessary follow-up actions resulting from the outcome of the planned mandatory emergency incident drill as required by BD53 (DMRB 3.1.6) and carried out during the commissioning of the tunnel prior to opening or re-opening. The drill shall involve extensive use of the active fire protection, communication, coordination and response provisions and the full participation of the Police and Emergency Services.

Chapter 9

- i. Communications and control systems, CCTV Alert
- ii. The automatic, static and temporary signing to be provided, in advance of and at the tunnel, for normal, maintenance and emergency traffic operations for the tunnel
- iii. The requirements for and siting of telephones

Chapter 11

- i. Possible hazardous consequences of failure of the incoming mains supply or a section of the tunnel internal power distribution network.
- ii. Security of supplies to essential equipment required to continue operating under mains power failure conditions, including duration requirements.
- iii. The effect on tunnel operation and safety of disconnection or removal of key items of equipment, eg transformers or circuit breakers, for maintenance or repair.

Chapter 13 and Appendix C

- i. Tunnel documentation requirements.

Appendix D

- i. Guidelines for major incident operations and fire tests.
- ii. An Initial Response and Traffic Control Plan shall be prepared by the TDSCG.

APPENDIX G - LIFE EXPECTANCY OF TUNNEL EQUIPMENT

G.1 Road tunnel whole life costs are determined not only by construction, operating and maintenance costs, but also by the cost of renewing equipment and installations which have a service life far less than that of the tunnel structure.

G.2 Service life is defined here as the period of duty after which replacement, rather than continued use, is anticipated to be justifiable on an economic or operational basis, either due to a greater risk of failure or to an unacceptable increase in unreliability, operating and maintenance costs.

G.3 Precise estimates of service life are not possible, since external influences (such as traffic changes, legislation changes, obsolescence, technology advances etc) may have a significant impact on the achievable life of tunnel equipment. The service life figures given shall be considered as guidance for typical values of current UK road tunnel equipment. Values need to be adjusted according to local conditions, better or worse than the average. Similarly, predictions of remaining service upon handback to the Overseeing Organisation of projects procured under Design Build Finance and Operate (DBFO) may be estimated on a project specific basis.

G.4 Examples of factors that may affect the service life of equipment or installations are given. Mitigation of such factors will increase the potential for reaching the intended service lives or longer.

Corrosive influences (see also Appendix B):

- i. Concentration and content of exhaust emissions
- ii. Ratio of HGVs to lighter vehicles
- iii. Cleaning agents, methods and frequencies
- iv. Use of road salt rather than acetates
- v. A marine environment
- vi. Weather conditions (ie prevalence of rain, wind, humidity snow, ice etc)
- vii. Impact of stones and debris
- viii. Water seepage or flooding

- ix. Non compatibility of materials in contact
- x. Fire damage of protective coatings
- xi. Stray current and field corrosion.

Intensity of Use:

- i. Traffic density and daily flow profile
- ii. Plant control methods, switching levels and frequencies
- iii. Weather conditions (eg number of sunny days for lighting, prevailing wind for ventilation)

Other Factors:

- i. Vibration
- ii. Thermal movement
- iii. Ambient Temperature
- iv. Ease of access for inspection or repair
- v. Fire or vehicle impact
- vi. Maintenance policy.

G.5 Because of the inherent difficulties in gaining access to tunnel equipment for maintenance or replacement, optimum whole life costs are often achieved by the selection of equipment having a longer service life or which has lower operating and maintenance costs. Service life values given are based on those normally achievable with high quality products, correctly maintained at the recommended intervals. In some instances subsidiary components may have a service life less than that of the main part of the equipment, and in such cases these have been listed separately.

Mechanical Plant

Ventilation

Jet Fans	18 years
Axial Fans	30 years
Electrostatic filters	10 years (estimated)

Drainage

Pumps	15 years
Water level detectors	10 years.

Fire Fighting

Hand Extinguishers	7 years
Hydrants	28 years
Hose reels	20 years
Fire main pipework	30 years
Sprinkler Systems	20 years
Fire detectors (Services Building)	10 years
Automatic Gas Discharge Systems	20 years.

Electrical Equipment

Power Supply and Distribution

Switchgear	20 years
Transformers	30 years
Cables HV	50 years
Cables LV, comms	40 years.

Standby Supplies

Diesel generators	20 years
UPS sets	15 years
Batteries:	
- valve regulated lead acid	5 years
- vented nickel cadmium	20 years.

Lighting

Luminaires	18 years
Ballasts and control gear:	
- conventional	20 years
- electronic	10 years
Lamps	Refer to Chapter 6
Guide lighting (emergency)	10 years.

Control Systems

CO, NO ₂ sensors	13 years
Visibility Monitors	15 years
Anemometers	20 years

Photometers	15 years
Computer and PLC systems	18 years (but may be obsolescent earlier).

CCTV Systems

Cameras	15 years (but may be obsolescent earlier)
Monitors	10 years (but may be obsolescent earlier)
Control equipment	20 years (but may be obsolescent earlier)
Cables	20 years.

Traffic Monitoring and Control Systems

Inductive loop systems	13 years
Signs and signals	14 years (but may be obsolescent earlier)
Control equipment	15 years (but may be obsolescent earlier)
Closure gates	15 years (13 years if automatic type)
Height detector	15 years.

Communications

Telephones	15 years
Telephone cabinet	20 years
Switch equipment	20 years (but may be obsolescent earlier)
Radio antenna cables	15 years
Transmitter/receiver equipment	15 years (but may be obsolescent earlier).

Fire Alarm and Detection systems

Detectors	
- in tunnel	5 years
- elsewhere	20 years
Control Equipment	20 years.

Tunnel Panels

Enclosure cabinets (stainless steel)	35 years
Distribution Boards	20 years
Fire fighting equipment	See above.

Fixings and support systems

Stainless steel	100 years
Hot-dip galvanised steel	15 years.



Bonneagar Iompair Éireann
Transport Infrastructure Ireland



Ionad Ghnó Gheata na
Páirce,

Stráid Gheata na Páirce,
Baile Átha Cliath 8, Éire



Parkgate Business Centre,
Parkgate Street,
Dublin 8, Ireland



www.tii.ie



info@tii.ie



+353 (01) 646 3600



+353 (01) 646 3601